

INSTRUCTION BOOK

Convertible Booster Restraint

Series No. BL90A/2010



IMPORTANT:
**KEEP THIS BOOKLET IN THE PLACE
PROVIDED ON THE CHILD RESTRAINT**

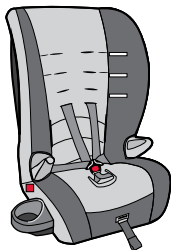

Forward Facing with in-built harness.

For children approximately 6 months to approximately 4 years of age, using the in-built harness.

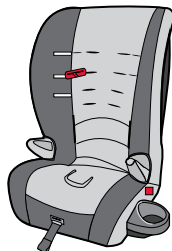

Forward Facing with Seat Belt.

For children approximately 4 years of age to approximately 6 to 8 years of age when used as a Booster Seat with lap-sash seat belt or Child Harness and seatbelt. (A Child Harness must be used in a position with a lap only seat belt).

Suitable for use only with the
Babylove EzyGo Harness™ Series BL220/2010 or
Safe-n-Sound™ Protecta PLUS™ Harness Series 220/2010
Child Harnesses.



PAGE

3	INTRODUCTION
4	WARNINGS
6	SHOULDER HEIGHT MARKERS & A GROWING CHILD
8	SHOULDER HEIGHT LABELS & THE NEXT STEP
10	FEATURES TODDLER USE
12	SUITABLE FOR USE
13	HOW TO USE
18	HOW TO SETUP
20	FEATURES CHILD USE
22	SUITABLE FOR USE
23	HOW TO USE
32	HOW TO INSTALL WITH A CHILD HARNESS
44	CARE AND MAINTENANCE
46	ACCESSORIES AND FEATURES
50	PRECAUTIONS
51	PRE INSTALLATION ANCHOR FITTING

The child restraint is suitable for toddlers and older children as a harnessed seat that can then convert to a Booster Seat for an older child. This child restraint is fitted with our exclusive **VERSATETHER™** catch that allows it to use the Babylove EzyGo Harness™ in Booster Seat mode for older children.

To be used in forward-facing position with in-built harness by children whose shoulders are above the lower shoulder height marker (approximately 6 months of age) until their shoulders reach the middle shoulder height marker (approximately 4 years of age). Then to be used with either a lap-sash seatbelt or an add-on accessory Child Harness until their shoulders reach the upper shoulder height marker (approximately 6 to 8 years of age).

Continue to use this child restraint until the child reaches this limit. Children are safest in a Booster Seat until their shoulders reach the upper shoulder height marker of the Booster Seat.

Do not use this restraint until child's shoulders are above the lower shoulder height marker.

Just using a seatbelt is not recommended for children that have outgrown this seat. Use a larger booster.

This product is only suitable for the use with the following Child Harnesses:

- Babylove™ EzyGo Harness™ Series BL220/2010 and
- Safe-n-Sound™ Protecta PLUS™ Harness Series 220/2010

WHEN USED WITH IN-BUILT HARNESS - TO BE USED WITH A LAP-SASH OR LAP ONLY SEAT BELT IN THE BACK OF MOST CARS WITH FORWARD FACING SEATS.

THIS BOOSTER MAY ONLY BE SUITABLE FOR USE IN UPRIGHT ONLY AS THE CAR'S SEATBELT MAY NOT BE LONG ENOUGH FOR USE IN THE RECLINED POSITION.

THIS RESTRAINT MUST BE USED IN CARS WITH FORWARD-FACING SEATS WITH A LAP-SASH SEATBELT AND CHILD HARNESS.

WHEN USED AS A BOOSTER SEAT:- THIS RESTRAINT MUST BE USED IN CARS WITH FORWARD FACING SEATS WITH A LAP-SASH SEAT BELT OR WITH A SEAT BELT AND CHILD HARNESS. When using a Child Harness with the seat it may be used in seating positions with either a lap or lap-sash seat belt.

THIS BOOSTER SEAT MAY ONLY BE SUITABLE FOR USE WITH A CHILD HARNESS IN THE UPRIGHT POSITION. IN THE RECLINE POSITION, THE CAR'S SEATBELT MAY NOT BE LONG ENOUGH.

No child restraint can guarantee absolute protection from injury in every crash. However, to ensure that your child gets all the protection designed into the restraint PLEASE READ AND FOLLOW THESE INSTRUCTIONS EXACTLY and use only Babylove recommended parts and accessories.

Carefully read all the instructions for installation in this book. If in doubt about the method of installation, consult Nursery Elegance or agent or a child restraint fitting station authorized by a relevant transport authority or, in New Zealand, the agent for the vehicle or authorized child restraint fitter.

THIS RESTRAINT MUST BE ATTACHED TO A CHILD RESTRAINT ANCHORAGE POINT IN THE CAR. REFER TO CAR OWNER'S HANDBOOK FOR LOCATION OF ANCHORAGE POINTS. REFER TO A CHILD RESTRAINT FITTING STATION IF NO ANCHORAGE POINTS ARE IN THE MOTOR CAR.

WARNINGS

WHEN USED WITH THE 'BUILT-IN' HARNESS

- Fit the restraint firmly to the car.
- Fit the harness firmly to the child.
- A loose restraint or harness is dangerous.
- When used in this mode the restraint must be fitted to the car with a lap or lap-sash seat belt.

AS A BOOSTER SEAT (with or without a separately supplied Child Harness)

- DO NOT USE WITH JUST A LAP BELT. You must use with a lap-sash belt or with a seat belt and Child Harness.
- The lap part of the seat belt must be firmly across the thighs and the sash straps fitted diagonally across the chest and on the shoulder.
- If used with a Child Harness, the lap strap of the seat belt must be adjusted firmly first and then the harness, so that the lap strap is not lifted off the child's lap when the harness is adjusted.
- DO NOT USE THIS RESTRAINT WITHOUT THE COVER.
- Do not use with the integral harness when in booster mode. This built in harness must be stored.
- Use only with a lap-sash seat belt or with an add-on accessory Child Harness and either a lap or lap-sash seat belt.

GENERAL WARNINGS- also see warnings on pages 12 and 22.

- Supervision of children is needed because they may be able to undo buckles and adjusters.
- Use the restraint exactly as shown in the instructions.
- DO NOT LEAVE CHILDREN UNATTENDED IN THE CAR.
- Do not alter or modify this restraint.
- Repairs must only be done by the manufacturer or agent. Use only recommended parts and accessories.
- Do not allow the restraint to come into contact with polishes, oils, bleach and other chemicals.
- Destroy the restraint if it has been in a severe crash, even if no damage is visible.

WARNINGS

- DO NOT USE THIS RESTRAINT WITHOUT THE COVER.
- Regularly check the restraint components, straps and other fitments for correct function and condition. Seek prompt repair.
- IF AN AIRBAG IS FITTED IN THE SEATING POSITION WHERE THE CHILD RESTRAINT IS TO BE FITTED, FOLLOW THE VEHICLE MANUFACTURERS WARNINGS AND INSTRUCTIONS.
- Straps may be damaged by unsecured cargo in a collision. Secure or remove hazardous cargo before using this restraint. **Hatch-back or Wagon:** Do not use the child restraint where this strap may fall into a split in the seat back. Always attach hook and remove slack.
- Protect all webbing from abrasion and cutting by sharp corners and edges.
- The restraint should not be purchased or sold as a second hand item. It is recommended not to use child restraints older than 10 years as the protection in an accident may be reduced.
- This restraint must be used in conjunction with a lap-sash seatbelt or lap seatbelt and a Child Harness in booster mode.
- THIS RESTRAINT IS NOT SUITABLE FOR USE WHERE THE ANCHORAGE STRAP MAY FALL INTO A SPLIT IN THE SEAT BACK (E.G. HATCHBACK OR WAGON).
- Seat belt extenders should not be used if the seat belt is not long enough to fit around the child. If a seat belt extender is used then the seat belt buckle must not be in contact with the child.
- Do not store in areas that may get hot, like in car boots, roof space, beside shed walls which get hot in summer. Do not place heavy items on top of the seat as this may distort the plastic

WARNING:

DO NOT LEAVE CHILDREN UNATTENDED IN THE CAR.

SHOULDER HEIGHT MARKERS & A GROWING CHILD

SHOULDER HEIGHT MARKERS

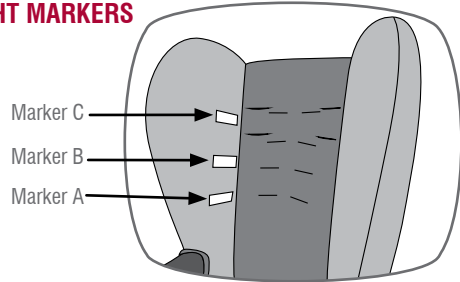

TODDLER MODE - USING IN-BUILT HARNESS

YOUNG TODDLER

Shoulders must not be below the lowest marker. Use the in-built harness. From approximately 6 months of age.

OLDER TODDLER

Shoulders in-line with middle marker. Change to Booster Seat mode. To approximately 4 years of age.

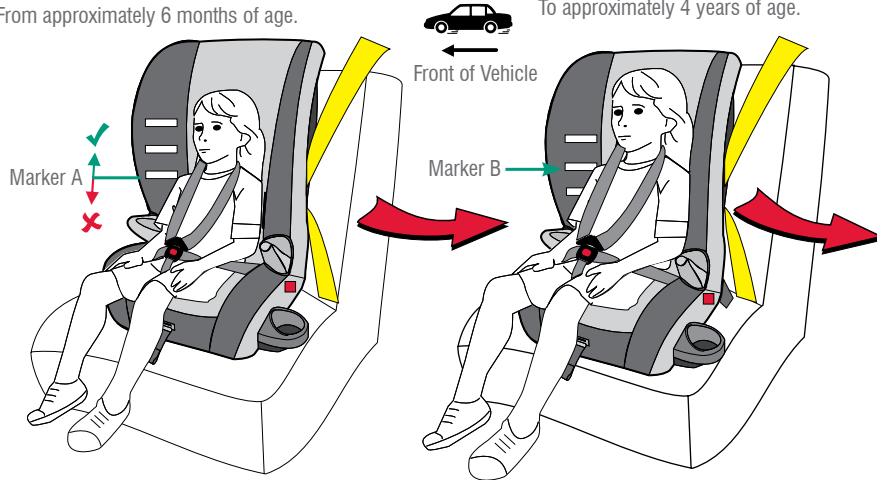

SHOULDER HEIGHT MARKERS & A GROWING CHILD

OLDER CHILD MODE - USE AS A BOOSTER SEAT

AS A BOOSTER SEAT WITH CHILD HARNESS AND SEAT BELT

To approximately 6 - 8 years of age.

OR AS A BOOSTER SEAT WITH LAP SASH SEAT BELT

To approximately 6 - 8 years of age.

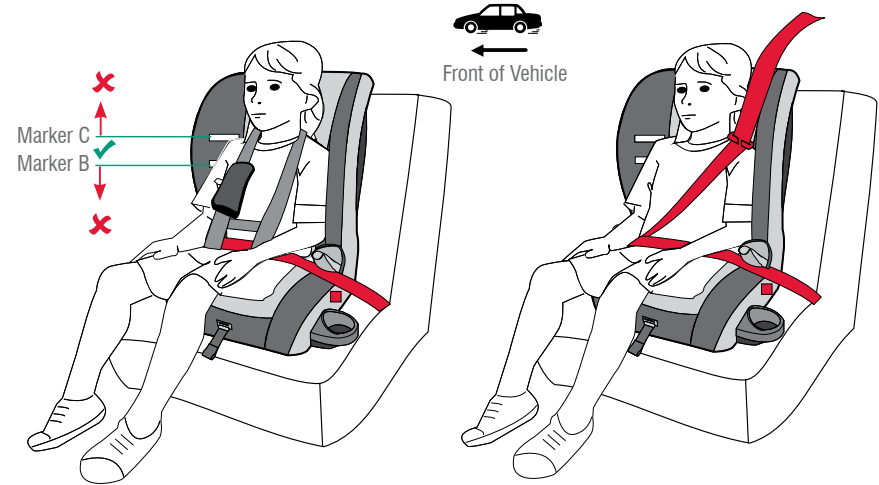

Change to the next type of Booster Seat or child restraint when shoulders reach the upper shoulder height marker.

A Child Harness must be used if the car's seating position is fitted with a lap only seat belt. If a child no longer physically fits in the seat then move to the next form of child restraint.

SHOULDER HEIGHT LABELS & THE NEXT STEP

⚠ IMPORTANT: Follow this advice.

Marker A Smaller Toddler - LOWER SHOULDER HEIGHT MARKER

Using the in-built harness, The child's shoulders must be in-line with this marker or above this marker. If the child's shoulders are below then the child should remain in their previous child restraint.

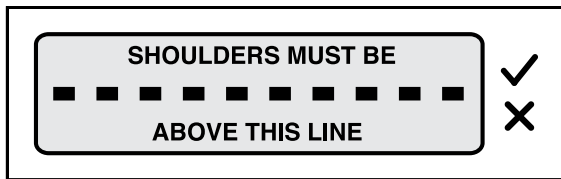

Marker B Larger Toddler - MIDDLE SHOULDER HEIGHT MARKER

When the child's shoulders reach this marker, convert the child restraint to Booster Seat mode and use either a lap-sash seat belt or a Child Harness and lap-sash seat belt or lap only seat belt.

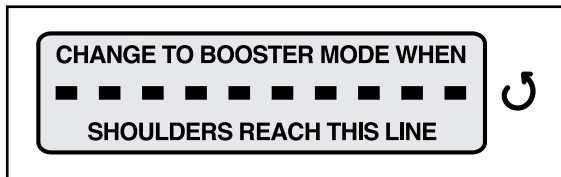

Marker C Larger Child - UPPER SHOULDER HEIGHT MARKER

When the child's shoulders reach this upper marker, or the child no longer fits in the child restraint, approximately 6 to 8 years of age, then the child must be moved to the next form of child restraint, see below.

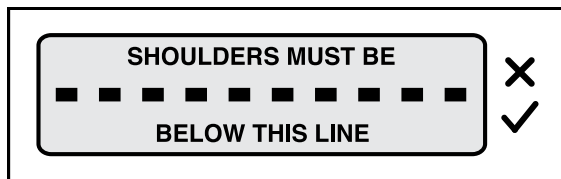

SHOULDER HEIGHT LABELS & THE NEXT STEP

Next type of restraint that can be used in the car for your child.

When your child has outgrown the seat, you can then either use:



You can use a narrow Booster Seat suitable for children up to 8-10 years of age. An accessory Child Harness may be used.

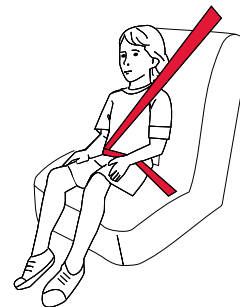

Or just the car's lap-sash seatbelt.



Or you can use a Child Harness and lap seat belt. Lap seat belts can be dangerous without a Child Harness.

FEATURES TODDLER USE

TODDLER USE

To be used only in a forward-facing position for a child whose shoulder height is between the middle and lower shoulder height markers, approximately 6 months of age, up to approximately 4 years of age using the in-built harness.

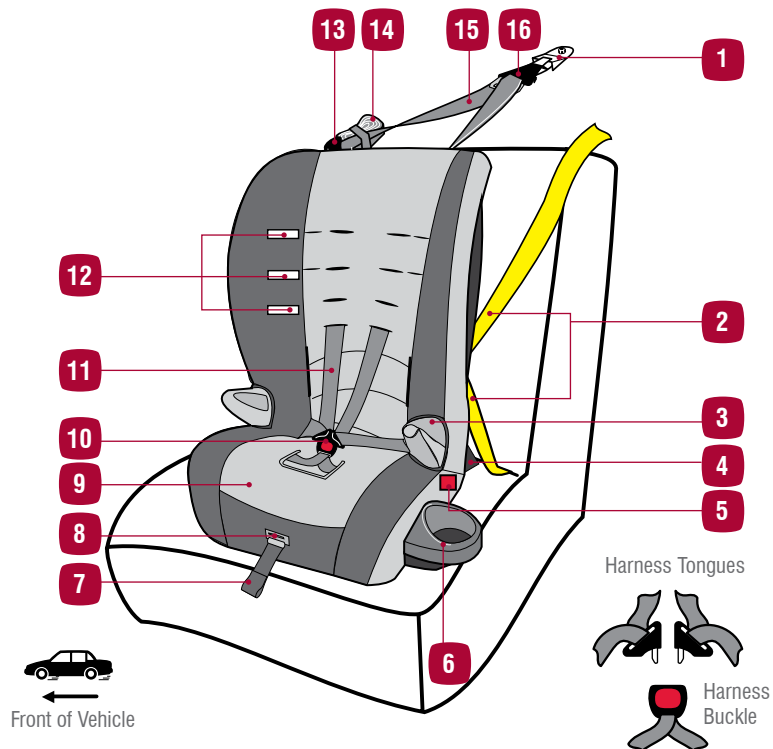

Front of Vehicle

FEATURES TODDLER USE

TODDLER USE

- 1 Anchor Fitting
- 2 Vehicle lap-sash seat belt or lap belt
- 3 Armrests
- 4 Recline Foot (shown in upright position)
- 5 Red Seat belt markers (each side) for booster mode (child use only).
- 6 Cup Holder (if fitted)
- 7 Harness Adjuster Strap
- 8 Harness Adjustment
- 9 Padded cover for comfort
- 10 Quick Release Harness Buckle (red button)
- 11 Fully adjustable 6 point harness
- 12 Shoulder Height Markers
- 13 Upper Anchorage Strap Adjuster
- 14 Upper Anchorage Storage band
- 15 Adjustable Upper Anchorage Strap
- 16 Attachment Clip, Cover and VERSATETHER™ catch

NOTE: Not all features are supplied on some models. "if fitted" is used to indicate some of the features that may not be on the seat supplied.

SUITABLE FOR USE

TODDLER USE

TO BE USED WITH A LAP SASH OR LAP ONLY SEAT BELT IN THE BACK OF MOST CARS WITH FORWARD-FACING SEATS.

To be used in forward-facing position with in-built harness by children whose shoulders are above the lower shoulder height marker (approximately 6 months of age) until their shoulders reach the middle shoulder height marker (approximately 4 years of age).

Continue to use this restraint until the child reaches this limit.

Do not use this restraint until the child's shoulders are above the lower shoulder height marker.

Infants are at risk of serious injury if they face forward too early.

The child should not sit in this forward facing child restraint until their neck muscles are able to support their head. Stay in a rear facing child restraint.

Regional Road Rules may prohibit the use of this restraint in the front seat until the child is 4 years of age. Check your Regional Rules for exemptions.

⚠️ WARNINGS

- Fit the restraint firmly to the car seat and then fit the harness firmly to the child.
- A loose restraint or harness is dangerous.
- Do not use this restraint if the child's shoulders are below the lowest shoulder height marker.
- Do not use in a front seat, unless it has a child restraint anchorage point i.e.: utilities.
- Do not use the restraint without the Upper Anchorage Strap correctly attached.
- Do not use on any vehicle seat which faces sideways or rearwards.
- WHERE AN AIRBAG IS FITTED IN THE SEATING POSITION WHERE THE CHILD RESTRAINT IS TO BE FITTED, FOLLOW THE VEHICLE MANUFACTURERS WARNINGS AND INSTRUCTIONS.

⚠️ IMPORTANT:

Use lap or lap-sash seat belt and upper anchorage strap to attach the child restraint to the vehicle seat when using the in-built harness.

HOW TO USE

TODDLER USE

ADJUSTING SHOULDER HARNESS STRAPS HEIGHT

Correct fitment of the harness is very important as it restrains the child in the restraint. The harness must fit firmly around the upper torso of the child and be positioned so as to leave the child's arms and legs free.

1. Top shoulder strap slots used for Child Harness
2. Upper shoulder strap slots.
3. Mid shoulder strap slots.
4. Lower shoulder strap slots.
5. Shoulder harness straps.
6. Harness tongues & buckle.
7. Lap strap slots.
8. Crotch strap slots.

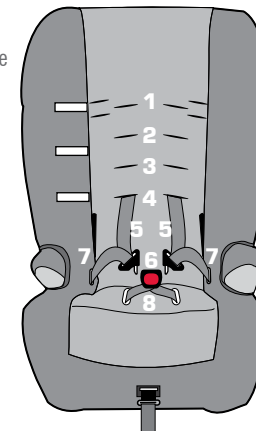

FOR TODDLER USE: The shoulder straps must be in the slots which are nearest to the child's shoulders, but not more than 25mm below the child's shoulders. If when in the top slots, the harness straps are more than 25mm below the level of the child's shoulders or child weighs more than 18kg, then the child is too large for the harness straps and the restraint should be now used as a booster. (Booster Mode - see pages 20 onwards).

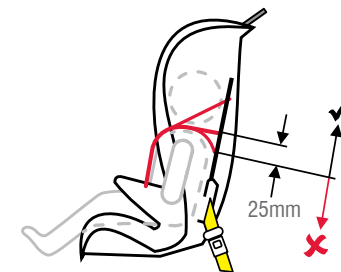

The shoulder straps must be in the slots which are nearest to the child's shoulders, but not more than 25mm below the child's shoulders.

SETTING UP THE HARNESS

- Sit the restraint against a wall for stability and get the child to sit comfortably in position.
- Determine the desired shoulder strap position as detailed on the previous page.
- Remove the child and adjust the shoulder straps as detailed below.
- Repeat steps A & B to confirm the correct set-up of the built-in harness.

STEPS IN CHANGING SHOULDER STRAP SLOTS

A. Remove the restraint from vehicle.

B. At the rear of the restraint, remove one of the harness shoulder straps from metal Strap Connector by slipping strap through open slot. The metal Strap Connector is shown in diagram right.

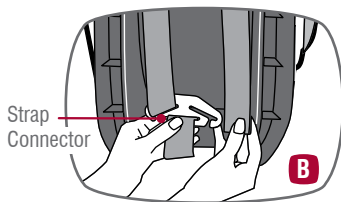

C. From the front, pull the shoulder strap out through shoulder slot.



D. Insert shoulder strap through restraint slot which will position shoulder strap level with or above the child's shoulder, shown above. Ensure that the Shoulder strap passes through matching slots in cover and restraint body.

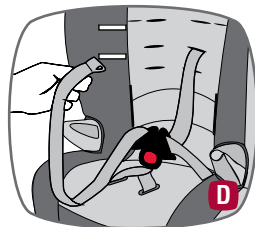

E. Ensure there are no twists in the harness strap and the buckle tongues face the correct way.

F. Connect shoulder strap to metal strap connector at rear of restraint.

G. Repeat for other shoulder strap. It is better to change one strap at a time so that the other strap will be a guide for re-assembly.

INSTALLING INTO VEHICLE (FORWARD-FACING) (UPRIGHT OR RECLINED)

A. Determine whether an upright or reclined installation is required.

B. To move the Recline Foot from upright to reclined mode or vice versa. Pull the Foot outwards to unlock it, then rotate the foot.

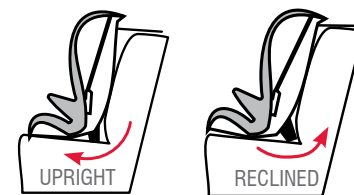

Push inwards to lock in place. See diagrams below.

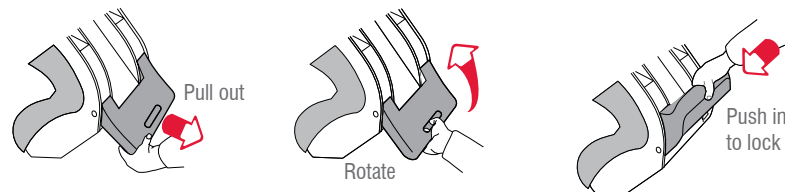

C. Position restraint centrally to the chosen position in forward facing mode and align restraint centrally to the chosen seating position. Some vehicle seat fabrics (particularly velours) may be damaged by a child restraint used continuously. We recommend the use of a thick towel or other protection under and behind the seat to keep the vehicle seat in good condition.

D. Fully lengthen lap or lap sash seat belt and insert through near seatbelt slot. Ensure the seatbelt is between the cover and seat back as you push the seatbelt through and out the far seatbelt slot.

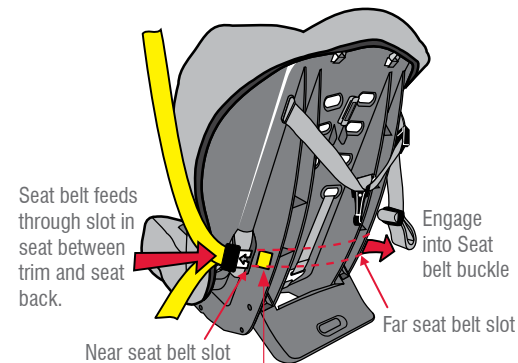

FORWARD-FACING SEATBELT PATH
(marked in yellow)

C D

HOW TO USE

TODDLER USE

E. Engage car seat belt buckle and tongue. Push down on the restraint while pulling on the lap portion to remove all slack from the belt. Then, pull the remaining slack in the sash belt and allow excess belt to feed back into the retractor.

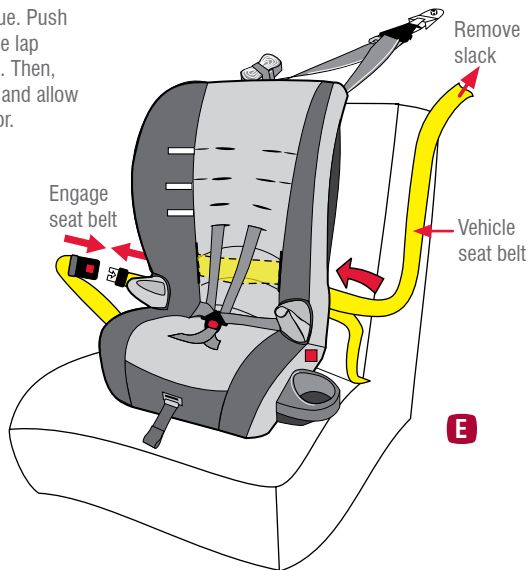

NOTE: Some vehicle seats have more rearward slope than others. Use a rolled up towel or padding under the seat for contoured vehicle seats to prevent excessive recline.

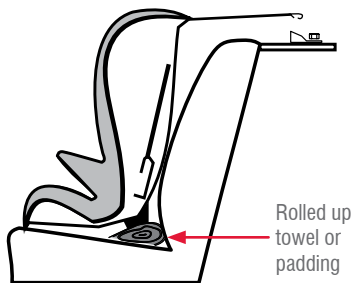

HOW TO USE

TODDLER USE

F. To lengthen the Upper Anchorage Strap, fully press Adjuster Button (A) while pulling Upper Anchorage Strap (B) to slacken as shown below.

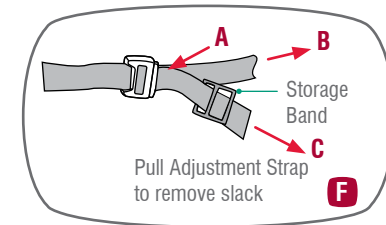

G. Fit the Attachment Clip to the Anchor Fitting making sure to remove as many twists as possible.

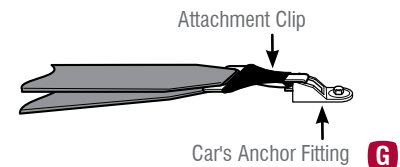

H. Pull Upper Anchorage Adjustment Strap (C) to remove any slack but do not tighten so much that the restraint lifts off the car seat. Roll up excess strap tightly and use storage band to neatly store excess strap behind seat.

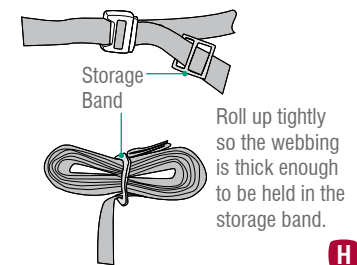

WARNING

Always attach hook and remove slack.

IMPORTANT :

Always ensure that the car seat belt and upper anchorage strap are firmly restraining the restraint on the vehicle seat.
Make sure Cup Holders (if fitted) do not interfere with closure of the car door.

HOW TO SET-UP

TODDLER USE

PLACING TODDLER IN THE RESTRAINT

A. Lengthen harness by lifting the adjuster lever while pulling on both shoulder straps until the harness will be longer than that required by the child.

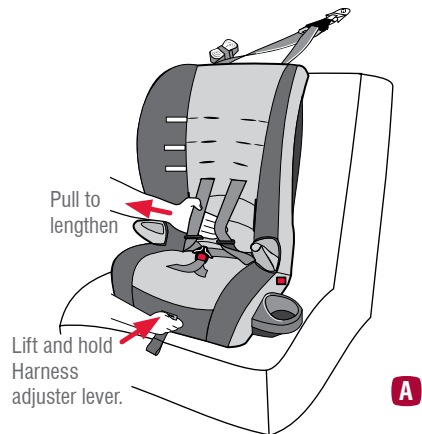
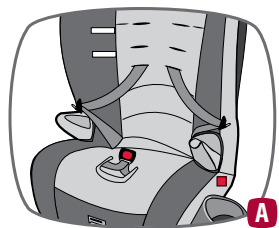

B. Place child in the restraint and feed each arm through shoulder straps. Pull harness buckle up between child's legs.

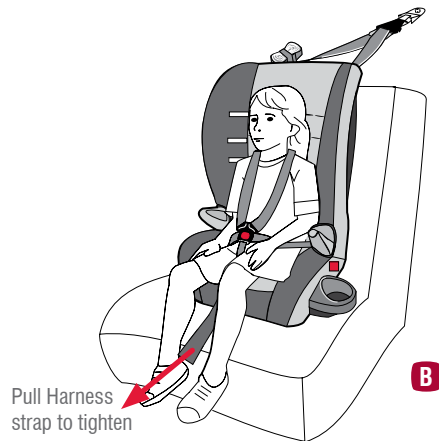

HOW TO SET-UP

TODDLER USE

C. Fit either harness buckle tongues into the harness buckle followed by the other tongue until a click is heard. Should the second tongue not insert then press the red button and reinsert the tongues. Ensure secure engagement by pulling harness straps.

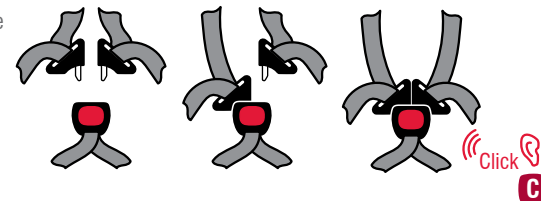

D. Ensure all slack is removed from the harness lap strap by pulling shoulder straps

E. Pull the harness adjuster strap to remove slack so the harness fits the child with minimal slack (see previous page). Shoulder straps must fit firmly to the child. A loose harness could result in serious injury in a crash. Do not over tighten.

Do not use restraint if straps do not tighten and contact your local authorised service agent for repair.

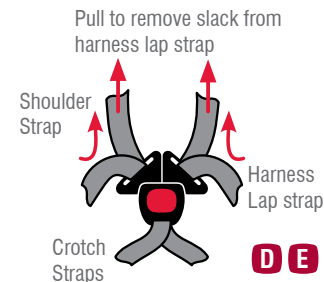

A LOOSE HARNESS IS DANGEROUS

TO REMOVE TODDLER

Press red button on harness buckle then both harness tongues will be released. Lift the shoulder straps from the child's shoulders and lift the child out of the seat. You may lengthen the shoulder straps if you wish but don't forget to retighten when you next use the restraint.

FEATURES CHILD USE

BOOSTER SEAT WITH SEATBELT

To be used with either a lap-sash seatbelt or an add-on accessory Child Harness by children whose shoulders are above the lower shoulder height marker (approximately 4 years of age) until their shoulders reach the upper shoulder height marker (approximately 6 to 8 years of age).

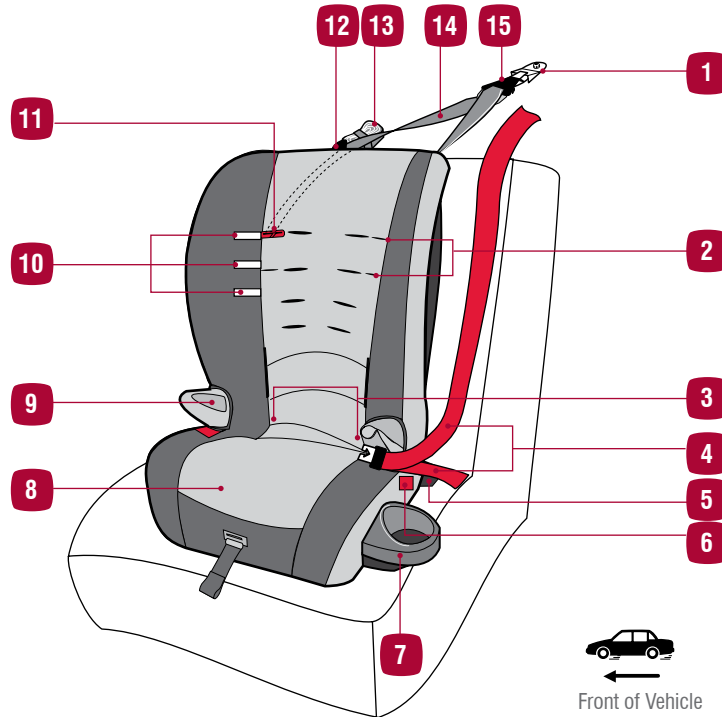

FEATURES CHILD USE

BOOSTER SEAT WITH SEATBELT

- 1 Car's Anchor Fitting
- 2 Sash Guide Slots (each side)
- 3 Harness stored in recess under cover trim
- 4 Vehicle lap-sash seatbelt
- 5 Recline Foot (shown in upright position)
- 6 Booster Seatbelt Path markers (each side)
- 7 Cup Holder (if fitted)
- 8 Padded cover for comfort
- 9 Armrests
- 10 Shoulder Height Markers
- 11 Sash Guide in position (hooked onto elastic behind cover)
- 12 Upper Anchorage Strap Adjuster
- 13 Upper Anchorage Storage band
- 14 Adjustable Upper Anchorage Strap
- 15 Attachment Clip, with VERSATETHER™ catch

NOTE: Not all features are supplied on some models. "if fitted" is used to indicate some of the features that may not be on the seat supplied.

BOOSTER SEAT WITH SEATBELT

To be used with either a lap-sash seatbelt or an add-on accessory Child Harness by children whose shoulders are above the lower shoulder height marker with the head restraint in the lowest position (approximately 4 years of age) until their shoulders reach the upper shoulder height marker with the head restraint in the highest position (approximately 6 to 8 years of age).

Continue to use this child restraint until child reaches the limit. Children are safest in a Booster Seat until their shoulders reach the upper shoulder height marker of the Booster Seat.

Do not use in this Booster Seat or child mode until the shoulders reach the middle shoulder height marker.

THIS RESTRAINT MUST BE USED IN CARS WITH FORWARD-FACING SEATS WITH A LAP-SASH SEAT BELT OR WITH A SEAT BELT AND CHILD HARNESS.

WARNING

Suitable only for use with the following Child Harnesses:

Babylove EzyGo Harness™ (series BL220/2010) and Safe-n-Sound Protecta PLUS™ harness (series 220/2010)

This seat is not suitable for use with any other child safety harness.

DO NOT USE WITH JUST A LAP BELT. You must use with a lap-sash belt or with a seat belt and Child Harness. If used with a Child Harness, the lap strap of the seat belt must be adjusted firmly first and then the harness, so that the lap strap is not lifted off the child's lap when the harness is adjusted.

Do not use with the integral harness when in booster mode.

This integral harness must be stored (see page 23).

Do not use the restraint without the Upper Anchorage Strap correctly attached.

Do not use with just a lap seat belt (unless using a Child Harness - refer to page 32-42).

Do not use in a front seat, unless it has a child restraint anchorage point and permitted under the local road rules.

Do not use on any vehicle seat which faces sideways or rearwards.

WHERE AN AIRBAG IS FITTED IN THE SEATING POSITION WHERE THE CHILD RESTRAINT IS TO BE FITTED, FOLLOW THE VEHICLE MANUFACTURERS WARNINGS AND INSTRUCTIONS.

CAUTION:

Upper anchorage strap must be used and properly connected at all times



CONVERTING INTO CHILD BOOSTER SEAT

To use this child restraint as a Booster Seat the harness and buckle needs to be stored under the cover.

Upper anchorage strap must be used in booster position.

The upper anchorage strap will need to remain connected after converting to a Booster Seat.

Disengage and remove the seat belt from the restraint.

If fitted, remove all accessories from the restraint.

STORING ACCESSORIES AND HARNESS IN SEAT RECESS

When used as a Booster seat, any accessories such as shoulder pads can be stored in the recess under the cover, as shown below. Other pads should be stored in a safe place for future use.

See the next page for detailed steps.

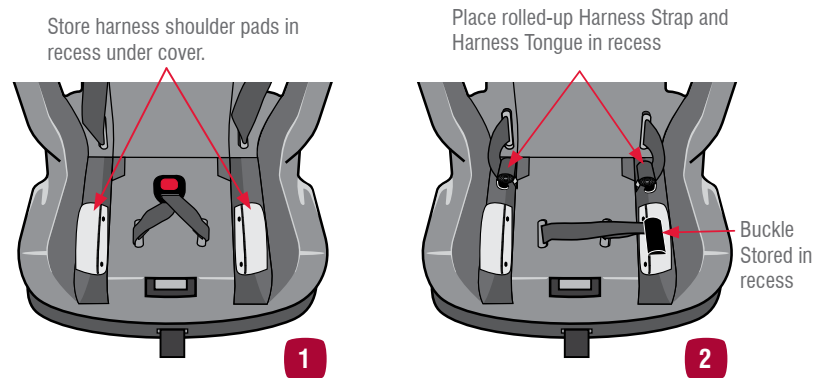

HOW TO USE

BOOSTER SEAT WITH SEATBELT

STORING THE HARNESS

A. Disengage harness buckle. Fully lengthen the harness by pressing the Harness Adjustment lever and pulling the harness shoulder straps.

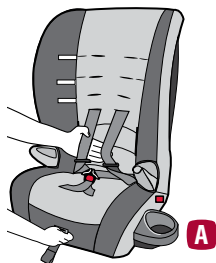

B. At the rear of the restraint, remove both of the harness shoulder straps from metal Strap Connector by slipping strap through open slot.

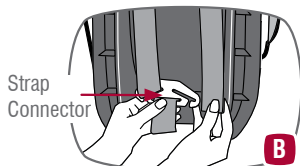

C. Pull the shoulder straps through slots in the seat back.

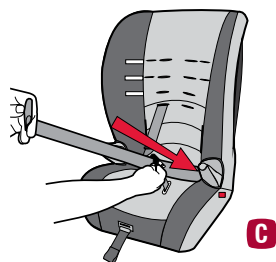

D. Remove the Elastic loops holding the cover in place at the lower front of the seat. Lift the cover to expose the storage inserts in the seat base.

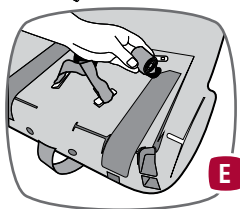

E. Feed the straps with harness buckle tongues through the bottom rear of the seat cover (see location shown by the arrow in drawing (C)). Roll up the harness straps with harness buckle tongue and place them into the left and right rear recess in the seat base (underneath the cover).

F. Roll up adjuster strap (with metal connector plate) and drop into pocket in recline foot.

G. Store pads (if fitted) in a safe place for future use, or under the cover. To store the buckle see page 23.

H. Align cover and re-engage elastic loops at the front of the cover.

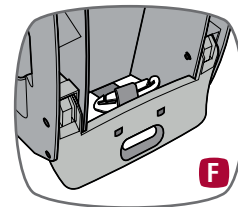

FIT THE SASH GUIDE

A. Unhook the elastic loops at the top rear of the restraint, then pull the cover forward to reveal the Sash Guide which is attached to a strap at the back of the seat cover.

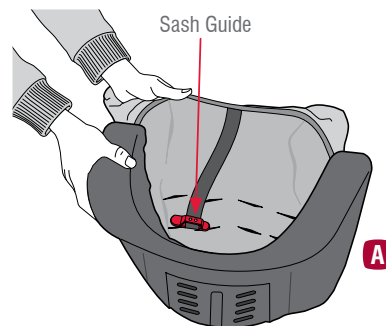

Thread the Sash Guide through the chosen slot in the seat cover. (See next page).

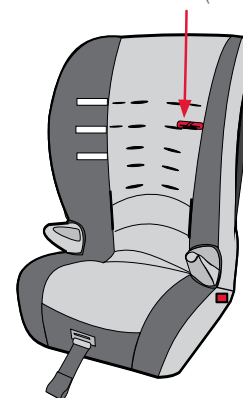

HOW TO USE

BOOSTER SEAT WITH SEATBELT

HOW TO USE

BOOSTER SEAT WITH SEATBELT

B. Fit the Sash Guide to the bottom Sash Guide slot of the cover then refit the cover.

C. If your child grows or if you are using the seat for a child that is not regular user then determine the correct height for sash guide.

Sit the restraint against a wall for stability and get the child to sit comfortably in position.

Determine the correct slot for the Sash Guide (refer to illustration right). There are 2 Sash Guide slots on each side of the seat cover, beside of the shoulder strap slots.

D. Sash Guide should be located just above the child's shoulders.

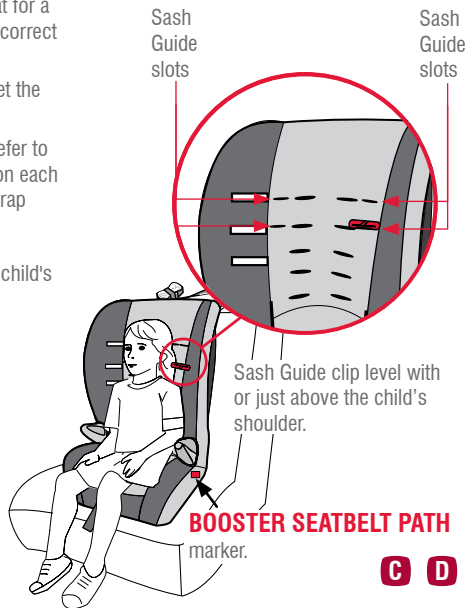

HOW TO USE

BOOSTER SEAT WITH SEATBELT

PLACING CHILD IN THE RESTRAINT USING LAP SASH SEATBELT

A. Determine whether an upright or reclined installation is required.

B. To move the Recline Foot from reclined to upright mode or vice versa, swing the seat to access the foot, pull the foot outwards to unlock it, then rotate the foot. Push inwards to lock in place. Swing the seat back until it sits firmly on the vehicle seat.

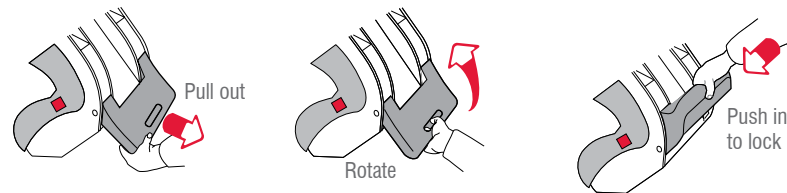
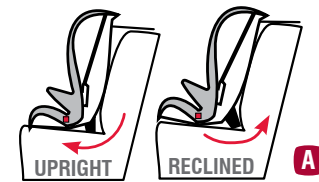

THIS BOOSTER SEAT MAY ONLY BE SUITABLE FOR USE ONLY IN UPRIGHT POSITION AS THE CAR'S SEATBELT MAY NOT BE LONG ENOUGH WHEN USED IN THE RECLINED POSITION.

HOW TO USE

BOOSTER SEAT WITH SEATBELT

C. Ensure the upper anchorage strap is still engaged into the anchor fitting or reattach and remove slack if necessary. Remove slack as shown on page 17. Do not overtighten causing the restraint to lift. The upper anchorage strap must be connected when using in this Booster Seat mode.

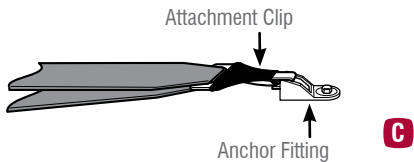

NOTE: Some vehicle seats have more rearward slope than others. Use a rolled up towel or padding under the seat for contoured vehicle seats to prevent excessive recline.

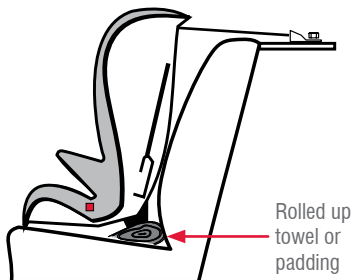

D. Sit the child on the restraint. So they are not slumping. Sit upright.



E. Position the lap-sash belt over the child ensuring the lap portion is positioned under the armrest as indicated by the red BOOSTER SEATBELT PATH label. The lap belt must be positioned low down on the thighs and hips of the child and not on the abdomen.

HOW TO USE

BOOSTER SEAT WITH SEATBELT

F. Engage seat belt buckle and tongue ensuring there are no twists in the belt. If the seat belt buckle is adjustable, adjust the buckle as low as possible away from the child.

G. Connect the sash of the seat belt to the Sash Guide at shoulder height.

The Sash Guide must be used to position the sash portion of the lap-sash seat belt across the child's shoulders and chest. Choose the Sash Guide slot nearest to but above the shoulder height of the child.

! IMPORTANT:
ALWAYS USE THE SASH GUIDE.

Adjust the sash guide so that it pulls the sash belt over the chest and the front of the shoulder. Do not over tighten.

H. Adjust lap and sash portion of seat belt firmly but comfortably across the child's lap and chest.

I. If using an Inertia Reel Retractor seat belt, adjust the lap portion of the seat belt firmly around the child and restraint and through the strap locator clip, then let the slack retract up into the sash retractor.

J. When not using the restraint, secure in position by engaging the seat belt over the seat.

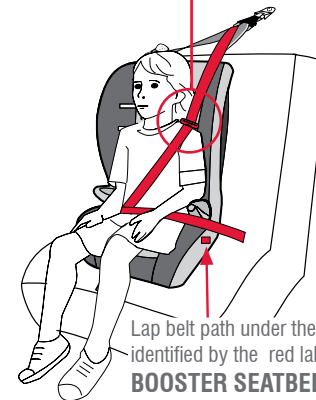
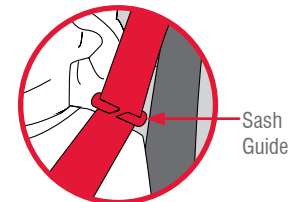
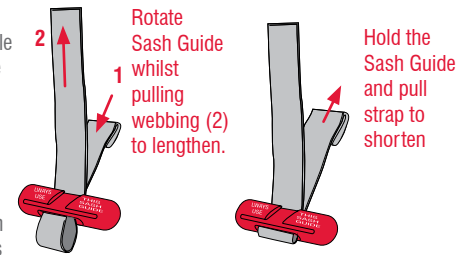

! WARNING :
A sash belt under the arm or behind the back is dangerous.



SEAT BELT UNDER THE ARM IS DANGEROUS



SEAT BELT BEHIND THE BACK IS DANGEROUS



Locate sash guide so it is close to the shoulders.

Seat belt across the chest.

Lap belt must always be firm on the thighs. The child must not slump or slouch.

NOTE: Do not use this Booster Seat if the child's shoulders are above the upper shoulder height marker.

TO STORE SASH GUIDE

When Sash Guide is not in use, Hook the Sash Guide at the back of the cover to the elastic loop.

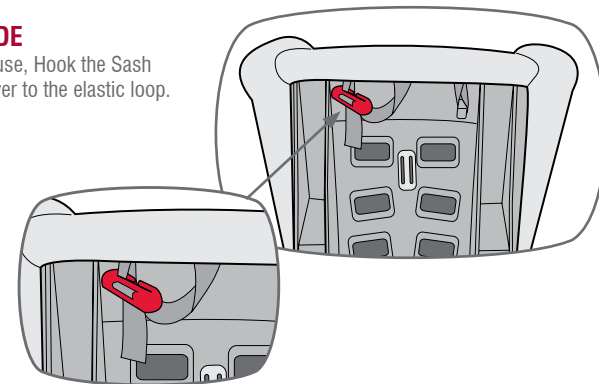

TO REMOVE CHILD

Disengage seat belt tongue and buckle, remove the lap portion of seat belt from child. When Booster is not being used, secure in position, by engaging seat belt over the Booster Seat.

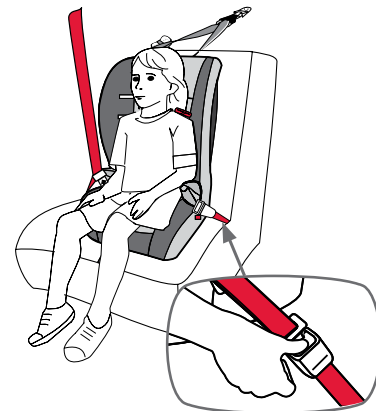

HOW TO INSTALL WITH A CHILD HARNESS

BOOSTER SEAT WITH CHILD HARNESS

USING WITH Babylove EzyGo Harness™ Series BL220/2010 or Safe-n-Sound™ Protecta PLUS™ 220/2010 Harness (purchased separately)

This Booster Seat is only suitable for use with Babylove EzyGo Harness™ Series BL220/2010 or Safe-n-Sound™ Protecta PLUS™ Harness Series 220/2010. Refer to the instruction book supplied with the Child Harness for full details of using and installing the Child Harness. When installing the Child Harness into the vehicle and Booster Seat, connect the upper anchorage strap to the **VERSATETHER™** Catch on the Booster Seat's upper tether strap (as shown below).

If required, use the extension strap supplied with the child harness for all other instances to attach the harness to anchor points in the luggage area such as the vehicle floor or ceiling. Not suitable for most other styles of child safety harnesses.

INSTALLING INTO VEHICLE WITHOUT EXTENSION STRAP

Hook the Child Harness attachment clip (1) onto **VERSATETHER™** Catch (2). Then hook attachment clip (3) onto anchor fitting (4). Ensure that none of the straps are twisted and not passing over any sharp edges.

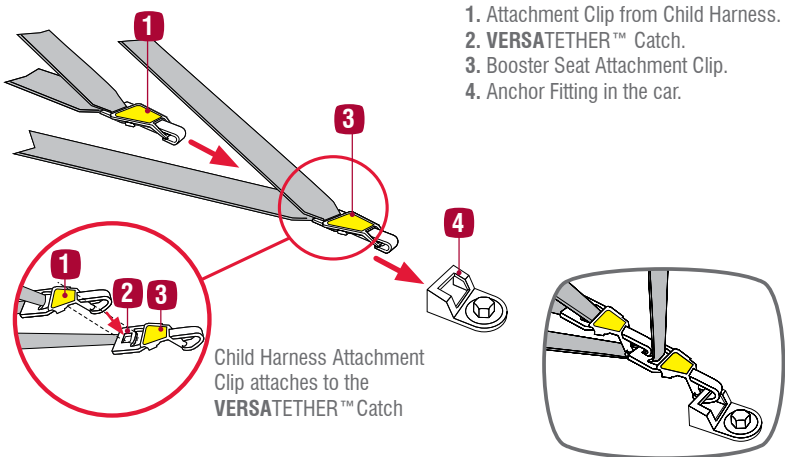

NOTE:

Do not use the **VERSATETHER™** catch on the Child Harness Clip (1). **VERSATETHER™** catch (2) is only for use with a Child Harness.

HOW TO INSTALL WITH A CHILD HARNESS

BOOSTER SEAT WITH CHILD HARNESS

INSTALLING Babylove EzyGo Harness™ Child Harness Series BL220 HARNESS WITH EXTENSION STRAP INTO VEHICLE

An adjustable extension strap is supplied with the Child Harness. Hook the Babylove EzyGo Harness™ Child Harness clip first onto the extension strap catch (6), then hook the extension strap hook onto the **VERSATETHER™** Catch on the Booster Seat's upper anchorage strap (2) as shown below. Attach the Booster Seat's attachment clip (3) to the car's anchor fitting (4) if not all ready attached. Ensure that none of the straps are twisted or catching on sharp edges. Tighten the Booster Seat's upper anchorage strap (refer to page 17) then remove excess slack from the extension strap by pulling the adjuster strap as illustrated below.

1. Attachment clip from the Child Harness
2. **VERSATETHER™** Catch
3. Booster Seat Attachment Clip
4. Anchor Fitting in the Car
5. Adjustable Extension Strap
6. Extension Strap Catch
7. Extension Strap Attachment Clip

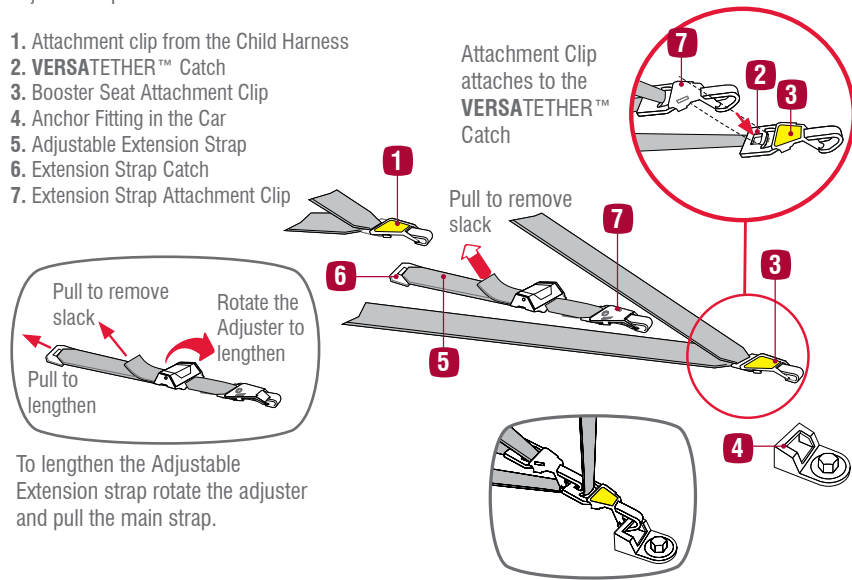

WARNING

Always attach the hook and remove the slack.

HOW TO INSTALL WITH A CHILD HARNESS

BOOSTER SEAT WITH CHILD HARNESS

CHOOSING METHOD OF INSTALLATION

The Child Harness can be installed using either of the following methods.

METHOD 1 : Using a lap sash seat belt in conjunction with Gated 3-bar Slide (provided with the Child Harness) to convert to lap belt plus upper anchorage strap.

METHOD 2 : Using lap seat belt plus upper anchorage strap.

Before installing the Child Harness determine which method of installation is required and follow instructions carefully.

NOTE: When using the Child Harness, ensure the 'in- built' shoulder harness is rolled up and stored in the recesses under the cover. Refer to pages 23-24 on storing the harness the crotch buckle must also be stored in the recesses under the cover. Roll up the metal connector and tuck it into the recess in the recline foot at the back of the seat.

IMPORTANT:

THIS BOOSTER SEAT MAY ONLY BE SUITABLE FOR USE WITH A CHILD HARNESS IN THE UPRIGHT POSITION. IN THE RECLINE POSITION, THE CAR'S SEATBELT MAY NOT BE LONG ENOUGH.

Some vehicle seat belts are too short and you may experience some difficulty fitting the converted lap-sash around your child. If so, adjust the gated slide nearer to your child, ideally under the armrest and lap belt recess area, (ensure the slide does not touch your child). This should provide more belt length to fit your child, but if the belt still will not fit, try another location in the vehicle, e.g. side seat. If the vehicle belts are still too short, then contact the vehicle manufacturer for advice on longer seat belts.

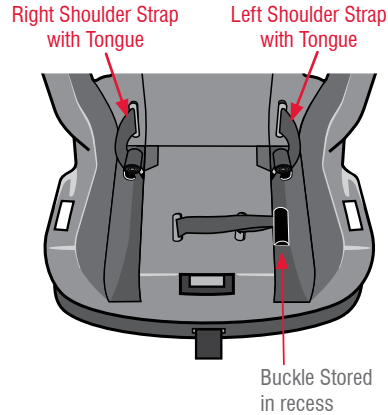

HOW TO INSTALL WITH A CHILD HARNESS

BOOSTER SEAT WITH CHILD HARNESS

INSTALLING CHILD SAFETY HARNESS INTO SEAT

A. Lengthen the Child Harness using the adjuster under the cover (see the Child Harness instructions on the adjustment method). Press the Adjuster button (1) on the adjuster and pull the shoulder strap (2).

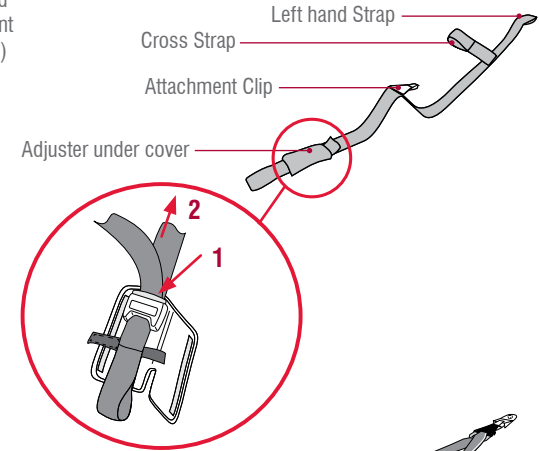

B. Feed the left hand Harness Strap & Cross Strap through the shoulder slots that are just above the child's shoulders. Make sure that the Attachment Clip also feeds through to the back of the restraint.

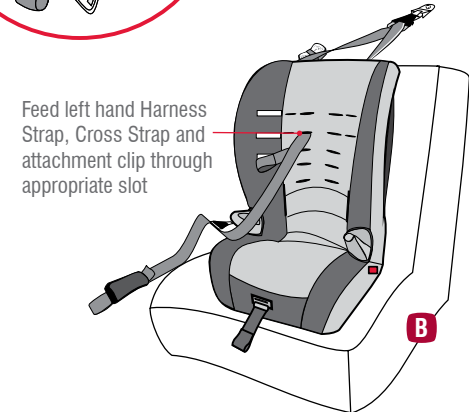

HOW TO INSTALL WITH A CHILD HARNESS

BOOSTER SEAT WITH CHILD HARNESS

C. Pull the left hand Harness Strap & Cross Strap through the opposite shoulder slot. Hook the Child Harness Attachment Clip onto the **VERSATETHER™** Catch and ensure that the straps line up to an equal length.

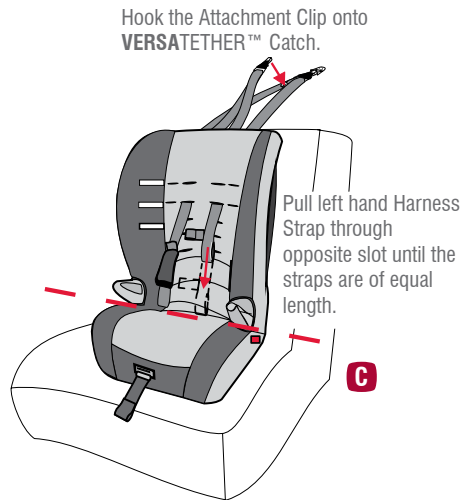

HOW TO INSTALL WITH A CHILD HARNESS

BOOSTER SEAT WITH CHILD HARNESS

METHOD 1: USING LAP-SASH SEAT BELT WITH CHILD SAFETY HARNESS.

Refer to the Harness instructions for fitting the gated slide to the lap-sash seat belt. Once fitted, position the gated slide near to the child (under the armrest) but not touching the child. Thread the converted lap-sash seat belt through the harness strap loops as shown left. Ensure there are no twists in the harness, cross strap and seat belt.

! IMPORTANT:

The Gated Slide must be removed from the seat belt if the Booster Seat and Child Harness are no longer used in the car to allow other users to use the seatbelt as a lap-sash seatbelt.

Important Note: Some vehicle seat belts are too short and you may experience some difficulty fitting the converted lap-sash around your child. If so, adjust the gated slide nearer to your child, (ensure the slide does not touch your child). This may provide more belt length to fit your child, but if the belt still will not fit, try another location in the vehicle, e.g., side seat. If the vehicle seatbelts are still too short, then contact the vehicle manufacturer for advice on longer seat belts.

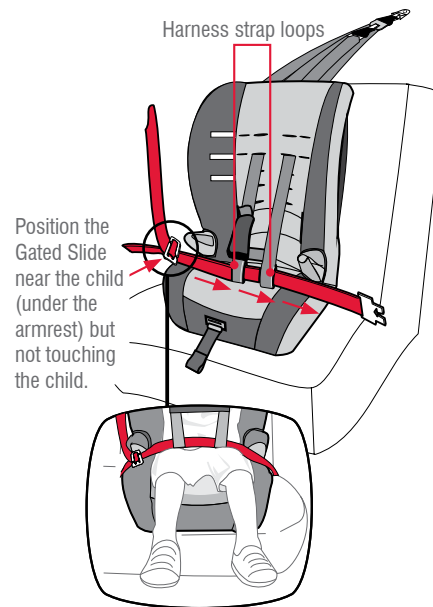
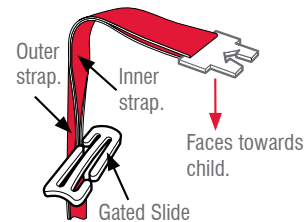

HOW TO INSTALL WITH A CHILD HARNESS

BOOSTER SEAT WITH CHILD HARNESS

FITTING THE GATED SLIDE TO THE LAP-SASH SEAT BELT

A. Hold the lap and sash straps together and fold as shown right. Slide the inner strap into the Gated Slide followed by the outer strap.

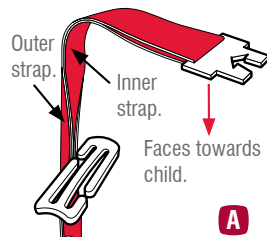

B. The two straps should slide freely in the Gated Slide slot.

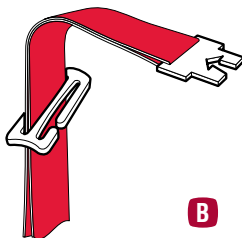

C. Repeat previous step **A** for the other slot in the Gated Slide.

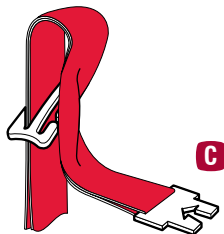

HOW TO INSTALL WITH A CHILD HARNESS

BOOSTER SEAT WITH CHILD HARNESS

D. Feed the straps through the Gated Slide to remove any slack.

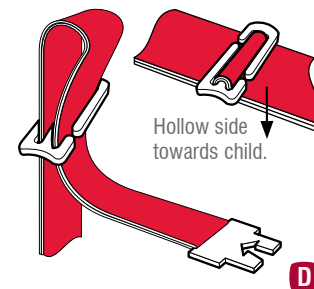

E. There may be two types of Gated Slides available, Curved and Flat.

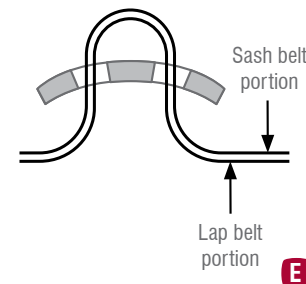
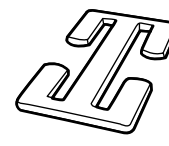
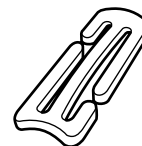

When fitting the Curved Gated Slide, the seat belt route can only go one way, as shown right.

HOW TO INSTALL WITH A CHILD HARNESS

BOOSTER SEAT WITH CHILD HARNESS

METHOD 2: USING LAP SEAT BELT WITH CHILD HARNESS.

Adjust the headrest to align with the top shoulder slots of the restraint. Fit the Child Harness as shown above. Then connect the cross strap as shown below. Thread the lap seat belt through the harness strap loops as shown right.

NOTE: Seat belt extenders should not be used if the seat belt is not long enough to fit around the child. If a seat belt extender is used then the seat belt buckle must not be in contact with the child.

Connect the Child Harness to the **VERSATETHER™** Catch as detailed on page 32.

A. With the child seated, place each of the harness straps over each shoulder.

B. Feed the Right hand strap (loop end) into the cross strap loop to connect the two sides.

C. Feed the adult belt (lap belt or converted lap/sash) through the harness loops, ensuring that the cross strap loop does not disconnect. Also ensure there are no twists in the harness, cross strap and seat belt

1. Left Hand Harness Strap
2. Right Hand Harness Strap
3. Storage strap
4. Cover Pad
5. Right Hand Harness Strap Loop
6. Cross Strap Loop
7. Cross Strap
8. Booster Seat Upper Anchorage Strap
9. Car's Anchor Fitting

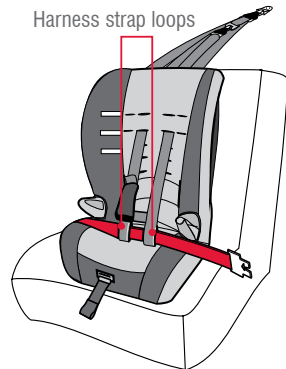
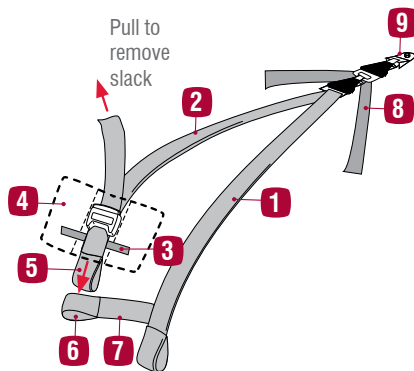

HOW TO INSTALL WITH A CHILD HARNESS

BOOSTER SEAT WITH CHILD HARNESS

D. Engage the seat belt tongue to the buckle and adjust the seat belt to sit firmly but comfortably around the child's pelvis. The seat belt buckle should be located as low as possible below the child's hip.

E. With the lap belt (or converted lap/sash) adjusted to be a firm fit on the child's thighs, then adjust the Child Harness to remove all slack in the shoulder straps. Once adjusted, further adjustments are necessary only to the upper extension straps and to accommodate the growth of the child.

F. Finally, roll up the free end of the harness's adjuster strap, then place it on the top of the adjuster, secure using the storage strap and close the cover pad.

G. To lengthen the harness at any time, fully pressing the Adjuster Button (1) whilst pulling the shoulder strap (2) upwards.

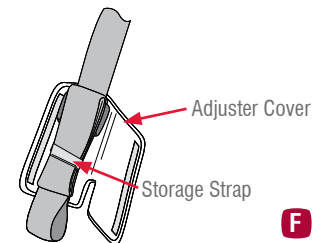
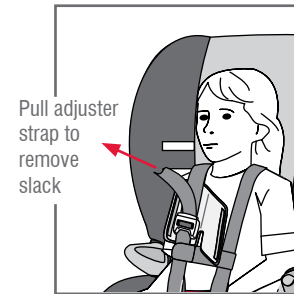

Fold the adjuster strap and secure with Storage strap.

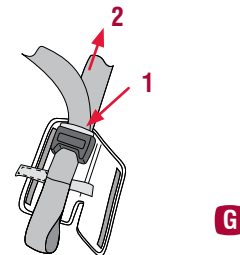

HOW TO INSTALL WITH A CHILD HARNESS

BOOSTER SEAT WITH CHILD HARNESS

The Child Harness should always be used in either of the top two rows of harness slots.

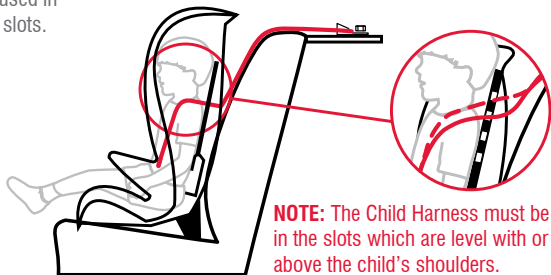

NOTE: The shoulder straps must be in the slots which are nearest to the child's shoulders but not lower than the child's shoulders. This is achieved with the headrest above the child's shoulders.

TO REMOVE CHILD

Disengage seat belt tongue and buckle, and remove belt from child.

NOTE: It may be easier to unthread the car seat belt out of the loops before lifting the Child Harness over the child's head.

When Booster is not being used, secure in position, by engaging seat belt over the Booster Seat.

NOTE: When Child Harness is no longer being used, disconnect the gated slide so that the seat belt can be correctly used as a lap-sash seat belt for other users.

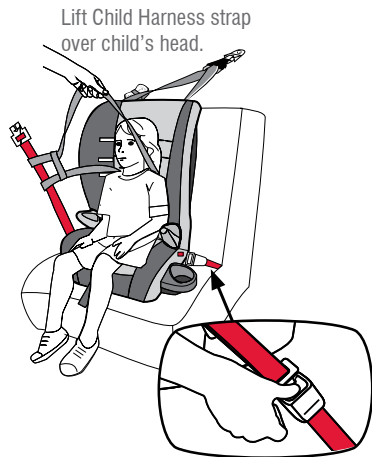

HOW TO INSTALL WITH A CHILD HARNESS

BOOSTER SEAT WITH CHILD HARNESS

RESTORING THE RESTRAINT FOR TODDLER USE

A. Disengage seat belt tongue from buckle and pull seat belt out of harness strap loops.

B. Disconnect the Harness attachment clip from the **VERSATETHER™** Catch and feed the left hand Harness Strap out the shoulder slot. Pull the right hand harness Strap to remove the harness off the seat. (Store the EzyGo Harness™ in a safe place for later use).

C. Remove the built-in harness from the storage recess under the cover. Feed crotch strap and shoulder straps through seat cover.

D. Feed shoulder straps through appropriate shoulder slots in the seat back and attach to metal Strap Connector as shown right.

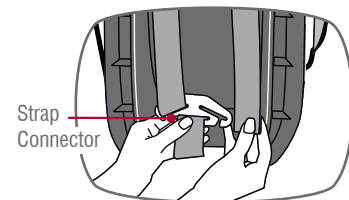

REGULAR CARE OF THIS RESTRAINT:

Please check the following items regularly to ensure the safety of your child:

- A. Check the webbing for fraying.
- B. Check that the buckle clicks and is not sluggish or sticky in operation.
- C. Ensure there are no cracks in moulding or the plastic moulding.
- D. Check the harness adjuster is operating and is clamping the webbing.
- E. If any part of the restraint is cracked or broken, seek repair immediately or replace the child restraint.
- F. Use only mild soap and water to clean all metal and plastic parts of the restraint. Do not use chemicals or cleaning agents.

TO CLEAN HARNESS BUCKLE:

If sticky liquids such as baby formula, fruit juice, etc. Get inside your Harness Buckle, it may become sluggish. An indication of a sluggish Harness Buckle is that you cannot hear a click when engaging the Harness Tongues. To restore the Harness Buckle to good working order it needs to be cleaned as follows:

- A. From the underside of the restraint pull each crotch 3-bar slide then turn 3-bar slide and push through each slot to remove the Harness Buckle from the restraint.
- B. Place the Harness Buckle under warm (max. 40 degrees Celsius) running water as shown below. Let the water run through the mouth of the buckle for five minutes.
- C. Engage and disengage the Harness Tongues and Buckles several times until a strong audible click is heard.
- D. If you still cannot hear a strong audible click after engaging the Harness Tongues & Buckle, then repeat cleaning several times. If the Harness Buckle cannot be returned to its original working condition then contact Babylove/Nursery Elegance Customer Service.
- E. Refit the harness buckle to the restraint with the red button facing out & feeding each 3-bar slide through appropriate slot.

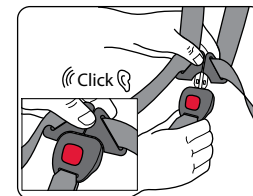
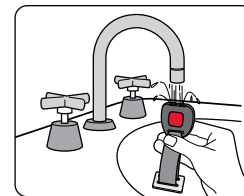
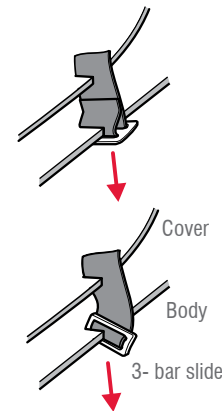

COVER

The restraint has a flame retardant cover which is removable for cleaning. Cleaning instructions are on the care label attached to the cover. When washing cover engage hook & loop strips together to eliminate other garments being caught.

The cover has been designed to protect your child when seated in the restraint. Care should be taken if children either eat or drink while in the restraint as some food or drink products may cause damage or marking to the cover.

IMPORTANT:

Do not pull sticky items from covers as the cover may be damaged - soak in water and gently remove.

TO REMOVE COVER

Follow the sequence below **A to G** (anti clockwise) to remove the cover.

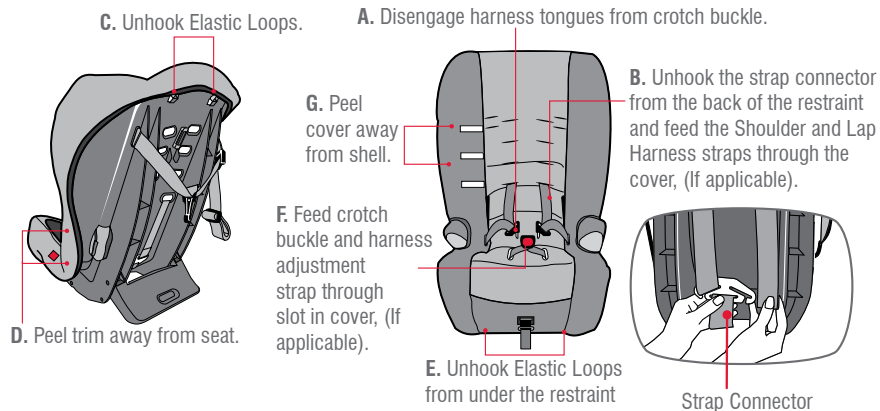

If the sash guide is in Booster Seat mode the sash guide can be left in place for washing.

If Child Harness is fitted remove the Child Harness.

REPLACE COVER

To replace cover refit in reverse sequence **G to A**.

- For the in-built harness or toddler mode, refit the harness through the same shoulder strap slots refer to pages 13 to 14 for harness adjustment and setup.
- For the Booster Seat mode, refit the cover and the sash guide should be in the same position. If the sash guide has fallen out of the slot refit by following the steps on page 23 to 26.
- If a child harness was fitted in the Booster Seat mode then follow steps on pages 32-42 to refit the Child Harness.

VERY IMPORTANT:

Only use this child restraint with the cover supplied or a manufacturer- authorised replacement cover with identical shoulder height markers.

ONLY USE BABYLOVE SEAT COVERS THAT ARE DESIGNED AND TESTED FOR USE WITH THIS PRODUCT.

The following instructions apply to accessories that may be supplied with this restraint at point of purchase. If not, a variety of accessories are available from various retailers of Babylove products.

CROTCH PAD (IF FITTED)

The Crotch Pad is designed to provide extra comfort for baby or child and is fitted to the restraint as follows: Feed Crotch Buckle through the slot in crotch pad as shown.

PADDED INSERT (IF FITTED)

The Padded Insert is designed to snugly support the baby for extra comfort. Simply place the padded insert on the restraint between Harness straps and the restraint back. Ensure padded insert is lined up with or below the shoulder straps.

Discontinue use if the Insert causes discomfort or when the child's shoulders reach the Middle Shoulder Height Marker. This will allow the child to use the in-built harness longer.

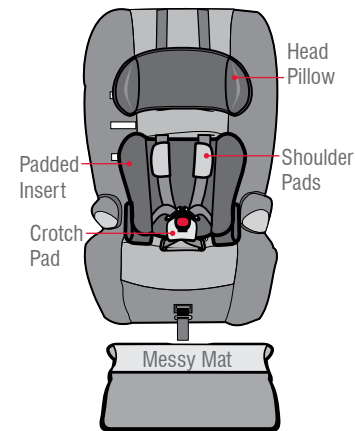

SHOULDER PADS (IF FITTED)

Shoulder Pads are designed to provide extra comfort for baby or child and are easily fitted to the shoulder harness straps by:

- Pull apart fasteners and remove shoulder pads from harness.
- Re-fit shoulder pads to harness and attach fasteners for use.

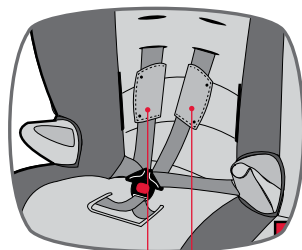

Shoulder Pads

HEAD PILLOW (WHERE FITTED)

The headrest is designed to provide extra comfort and is suitable for use with the in-built harness and when used in the Booster Seat Mode with a Child Harness.

Fit straps through the desired pair of Upper Shoulder Strap Slots to suit the size of the child and over the top of the restraint as shown right. Slide Head Pillow up or down to rest above the shoulder strap slots being used.

CAUTION:

Do not use any other Head Pillow as they may cause the seat to offer less protection.

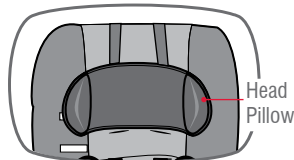

Head Pillow

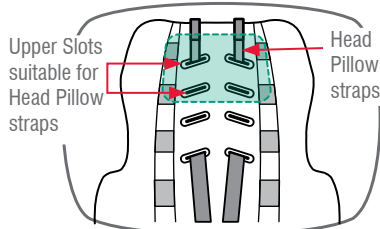

Upper Slots suitable for Head Pillow straps

Head Pillow straps

Head Pillow straps should be over the top of the restraint and through either pair of top slots

CUP HOLDERS (IF SUPPLIED)

The Booster Seat has the facility to fit a cup holder on either side of the seat. Fit the cup holder onto the seat to use. Ensure the cup holder and its contents can not be crushed by the car door. Cup Holder can be removed if not in required.

IMPORTANT:

Only use for holding cups, bottles and drink cartons. Do not use for hot drinks

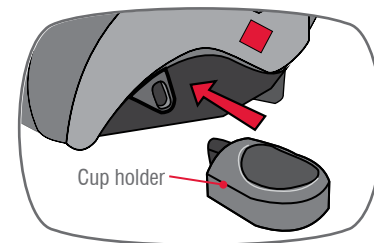

Cup holder

MESSY MAT™ SEAT PROTECTOR (IF SUPPLIED)

Place ribbed or pocket end of the Messy Mat™ seat protector on edge of car seat, smooth back toward seat join ('A') and fit in any excess Messy Mat™ into the join of the car seat ('A').

Hook and loop attachment referred in some instruction books, are no longer required to fit this model of Messy Mat™ seat protector.

CAUTION:

The pocket is only for small, light items. DO NOT overload the pocket with heavy, bulky items as this may damage the pocket or cause passengers to trip over them.

Short Messy Mat™

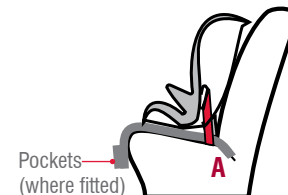

Pockets (where fitted)

Long Messy Mat™

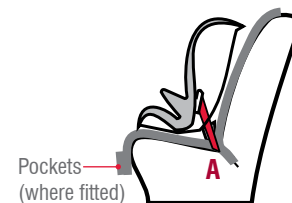

Pockets (where fitted)

⚠️ Precautions to prevent reducing the safety offered by this child restraint.

With In-built Harness

1. Ensure seatbelt is fitted to the seat.
2. Ensure upper anchorage strap is attached to the car's anchor fitting and slack is removed.
3. Ensure the in-built harness is firmly to the child. A loose harness is dangerous.

As a Booster Seat

1. Ensure the seatbelt is used and fitted correctly. The lap belt must be on thighs and not the abdomen and the sash belt must always be across the chest and over the shoulder.
2. Always thread the sash belt through sash guide.
3. Do not cause the seat to be reclined in any way.
4. Ensure the child does not slouch or slump where the Lap belt is across the abdomen. This is dangerous.
5. Do not place the seatbelt behind the back or under the arm. It is dangerous.
6. Do not use the seat belt in any other way other than following the red BOOSTER SEATBELT PATH seat belt path labels.
7. Ensure that if you are using a child safety harness that the lap belt is firm on the child's thighs and not on the abdomen. Do not tighten the Child Harness tether strap, just remove slack.
8. Ensure you advise the child not to undo the seat belt buckle unless told to do so.
9. Always use the sash Guide set at the correct height to guide the sash across the chest and over the shoulder.

Consult the vehicle owner's handbook for location of anchorage fittings or anchorage points and the possible use of spacers. Some vehicles may have an anchor fitting fitted by the vehicle manufacturer. If anchorage points cannot be found refer to car manufacturer or local child restraint fitting station or traffic authority for optimum position of anchorage point and the use of spacers.

⚠️ IMPORTANT:

THE ATTACHMENT CLIP COVER MUST ALWAYS BE USED AS IT PREVENTS THE RISK OF INCORRECT FITMENT OF THE ATTACHMENT CLIP TO THE ANCHOR FITTING. ALWAYS ENSURE THAT THE ATTACHMENT CLIP IS CORRECTLY ENGAGED TO THE ANCHOR FITTING AND NOT HOOKED OR FITTED TO ANY OTHER OBJECT BEFORE EACH USE OF THE RESTRAINT. THIS IS ESPECIALLY IMPORTANT IN VEHICLES SUCH AS STATION WAGONS, VANS, HATCH BACKS OR VEHICLES WITHOUT A FIXED PARCEL SHELF, SINCE THE ANCHOR POINT IS USUALLY NOT VISIBLE.

IMPORTANT INSTALLATION NOTE:

In some vehicles the anchor fitting in the rear vertical panel can only be installed in one way. Please refer to vehicle owner's handbook or a child restraint fitting station for correct method.

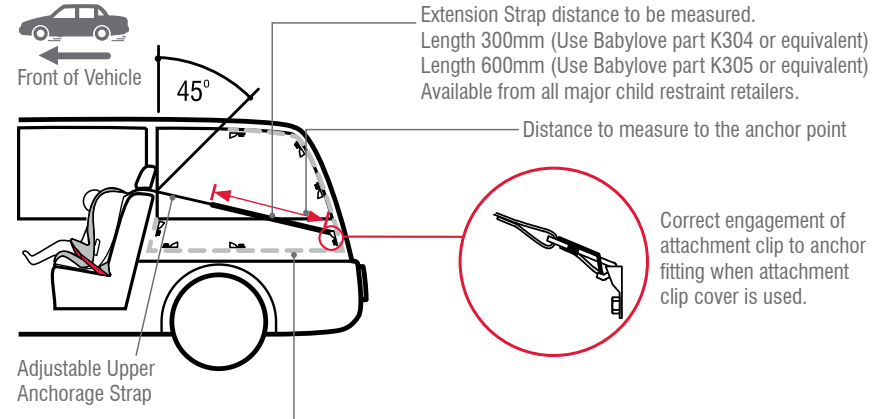

The shaded areas of this diagram illustrate the possible locations of the anchor fitting. Within each shaded area is an anchor fitting showing the correct way to install the fitting. Ensure the anchor fitting is aligned as illustrated unless stated otherwise in the vehicle Owners handbook.

PRE-INSTALLATION ANCHOR FITTING

IF THE CAR IS FITTED WITH CHILD RESTRAINT ANCHORAGE POINT

Locate the anchorage point behind the rear seating position. (consult the car owners handbook for the location of the anchorage point). The anchorage point should be directly behind and central to the restraint. Remove thread plug from the parcel shelf/floor/roof, etc. and install anchor bolt and fitting as shown in Fig.1.

CAUTION: DO NOT OVERTIGHTEN ANCHOR BOLT. OVERTIGHTENING MAY FRACTURE OR BREAK BOLT. MAXIMUM TORQUE IS 20 N.M. (14.75 ft.lb.)

Note: Minimum of five full turns of anchor bolt is required before tightening force is applied.

IF THE CAR IS NOT FITTED WITH CHILD RESTRAINT ANCHORAGE POINTS

For Sedans only - Drill 9mm diameter hole in the parcel shelf on the centre line of the seating position as shown in Fig.3. Before drilling the hole, check the underside for accessibility. Install the anchor bolt as shown in Fig.2.

For vehicles other than Sedans - In Australia, consult your nearest child restraint fitting station or traffic authority for vehicle inspection to find the best, correct position for the placement of the anchorage point, and for the correct attachment bolt length and use of spacers. In New Zealand, consult the agent for the vehicle.

Note to Queensland purchasers: The installation of anchorage points must be approved by authorised officers appointed by Queensland Transport. Authorised officers can be sourced from all Queensland Transport Customer Service and Queensland Ambulance Service Centres.

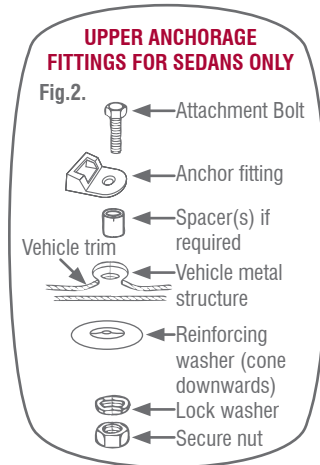
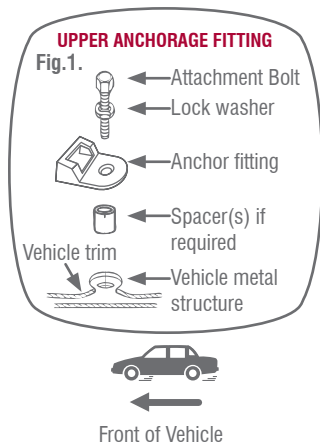

PRE-INSTALLATION ANCHOR FITTING

ONLY USE A 5/16 UNC GRADE 5 BOLT. IF THE BOLT IS NOT THE CORRECT LENGTH THE CAR MANUFACTURER'S HAND BOOK CAN PROVIDE ADVICE ON THE CORRECT LENGTH BOLT.

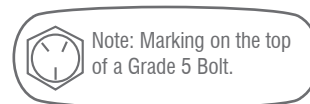

WARNING

CHILD RESTRAINTS MUST NOT BE ATTACHED TO UNSOUND METAL OR TO WOOD, OR SYNTHETIC STRUCTURES. WHEN DRILLING 9 MM HOLE DO NOT DRILL THROUGH FUEL LINES, FUEL TANKS, ELECTRICAL WIRING, OR RADIO SPEAKERS.

WEBBING STRAPS MUST BE PROTECTED FROM SHARP CORNERS AND EDGES. THE ANCHOR FITTING MUST BE USED ONLY AS DESCRIBED ABOVE. IT MUST NOT BE HOOKED ONTO ANY OTHER OBJECT.

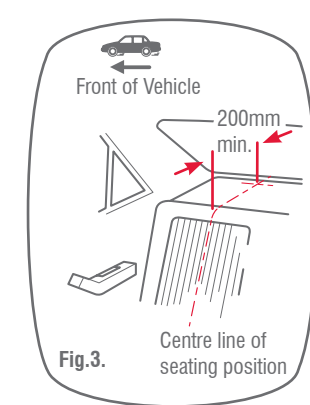

VEHICLE INSTALLATION ACCESSORIES

(Available from retailers of Babylove products)

EXTRA ANCHOR KITS: Are available if using the restraint in additional vehicles.

Re-order number: K402

EXTENSION STRAPS: May be required for vehicles without a fixed parcel shelf.

Re-order number: K304 (length 300mm)

or K305 (length 600mm).

GATED 3-BAR SLIDE: For converting lap-sash seat belt to lap belt for the Child Harness (supplied with the Child Harness) Also to obtain a better fit to the car where the seatbelt may loosen although most cars will not need this.

Re-order number: K403.

If your restraint has been involved in a severe crash, you should destroy the restraint even if no damage is obvious. Some insurance companies offer vehicle insurance which covers or partially covers the replacement of your child restraint. Contact your insurance company for further details. Your insurance company may require you to keep the child restraint for assessment, **but do not use the child restraint after a severe crash.**

AUSTRALIA

Nursery Elegance Pty Ltd.

A.B.N 84 122 443 387

Phone number: 1300 131 477

NEW ZEALAND

Phone number: 0508 688 822

www.nurseryelegance.com.au

info@nurseryelegance.com.au

We reserve the right to alter this product without notice in our constant endeavor for improvement.

©2007-2011 Nursery Elegance Pty. Ltd.

Babylove, EzyGo Harness Trademarks are the property of Nursery Elegance Pty Ltd.

Safe-n-Sound, Protecta Plus and VERSATETHER trademarks are the property of Britax Childcare Pty Ltd.

VERSATETHER is used by permission of Britax Childcare Pty Ltd.

This product is covered by Australian and Overseas patents and applications.

Patents Pending.