

Breville

Breville Customer Service Centre

Australian Customers

Mail: PO Box 22
Botany NSW 2019
AUSTRALIA

Phone: 1300 139 798

Fax: (02) 9384 9601

Email: Customer Service:
askus@breville.com.au

New Zealand Customers

Mail: Private Bag 94411
Botany Manukau 2163
Auckland NEW ZEALAND

Phone: 0800 273 845

Fax: 0800 288 513

Email: Customer Service:
askus@breville.com.au

www.breville.com.au

Breville is a registered trademark of Breville Pty. Ltd. A.B.N. 98 000 092 928
Copyright Breville Pty. Ltd. 2013

Due to continued product improvement, the products illustrated/photographed
in this brochure may vary slightly from the actual product.

Breville

the Flavour Maker

Instruction Booklet



BSC560

CONGRATULATIONS

on the purchase of your new Breville product

CONTENTS

- 4** Breville recommends safety first
- 7** Know your Breville product
- 9** Before first use of your Breville product
- 13** A beginner's guide to slow cooking
- 18** Hints and tips
- 20** Care and cleaning
- 22** Recipes

At Breville we are very safety conscious. We design and manufacture consumer products with the safety of you, our valued customer, foremost in mind. In addition we ask that you exercise a degree of care when using any electrical appliance and adhere to the following precautions.

IMPORTANT SAFEGUARDS

READ ALL INSTRUCTIONS BEFORE USE AND SAVE FOR FUTURE REFERENCE

- Remove and safely discard any packaging material and promotional labels before using the slow cooker for the first time.
- To eliminate a choking hazard for young children, remove and safely discard the protective cover fitted to the power plug of this appliance.
- Do not immerse appliance, power cord or power plug in water or any other liquid.
- Always insert the connector end of the power cord into appliance inlet before inserting power plug into power outlet and switching on appliance. Ensure the appliance inlet is completely dry before inserting the connector end of the power cord.
- Do not place the slow cooker near the edge of a bench or table during operation. Ensure the surface is level, clean and free of water and other substances.
- Do not operate the slow cooker on a sink drain board.
- Do not place this appliance on or near a hot gas or electric burner, or where it could touch a heated oven. Position the slow cooker at a minimum distance of 20cm away from walls and provide adequate space above and all sides for air circulation.
- We recommend the slow cooker is not placed on a stone bench top when it's cooking. This is due to bench tops being sensitive to uneven heat and may crack if heated locally. If you would like to cook with the slow cooker on the bench top, place a chopping board or heat proof mat underneath the slow cooker.
- Do not touch hot surfaces. Use handles to move slow cooker and dry oven mitts to remove the stainless steel lid and/or removable EasySeal™ pan when hot.
- Use only the removable EasySeal™ pan and lid supplied. Do not use any other pan inside the slow cooker base.
- Never plug in or switch on the slow cooker without having the removable EasySeal™ pan placed inside the slow cooker base.
- Do not place food or liquid into the stainless steel housing. Only the removable EasySeal™ pan is designed to contain food or liquid.
- Never operate the slow cooker without food and liquid in the removable EasySeal™ pan. Ensure the removable EasySeal™ pan is at least ½ to ¾ full of food and/or liquid before switching on the appliance.
- Do not use a damaged removable EasySeal™ pan. Replace before using.
- Extreme caution must be used when the appliance contains hot food and liquids. Do not move the appliance during cooking.

- Do not place the removable EasySear™ pan when hot on any surface that may be affected by heat.
- Do not use the EasySear™ pan for food storage.
- Do not use the removable EasySear™ pan in a microwave oven.
- Do not reheat food using your slow cooker.
- Always slow cook with the stainless steel lid on, for the recommended time.
- Avoid scalding from escaping steam when removing the stainless steel lid from the removable EasySear™ pan when hot by carefully lifting the lid angled away from yourself.
- Do not allow water from the lid to drip into the slow cooker base, only into the removable EasySear™ pan.
- Do not attempt to operate the slow cooker by any method other than those described in this book.
- Always ensure the slow cooker is properly assembled before operating. Follow the instructions provided in this book.
- The appliance is not intended to be operated by means of an external timer or separate remote control system.
- Do not place anything, other than the stainless steel lid, on top of the slow cooker when assembled, when in use and when stored.
- Always turn the temperature control dial to the 'Off' position, switch off at the power outlet, unplug the power cord from the power outlet, remove the connector end of the power cord from the appliance and allow the appliance to cool, if appliance is not in use, before cleaning, before attempting to move the appliance, disassembling, assembling and when storing the appliance.
- Keep the slow cooker clean. Follow the cleaning instructions provided in this book.



WARNING

Hot surfaces during and after use.

IMPORTANT SAFEGUARDS FOR ALL ELECTRICAL APPLIANCES

- Fully unwind the power cord before use.
- Do not let the power cord hang over the edge of a bench or table, touch hot surfaces or become knotted.
- To protect against electric shock do not immerse the power cord, power plug or appliance in water or any other liquid.
- The appliance is not intended for use by persons (including children) with reduced physical, sensory or mental capabilities, or lack of experience and knowledge, unless they have been given supervision or instruction concerning use of the appliance by a person responsible for their safety.
- Children should be supervised to ensure that they do not play with the appliance.
- It is recommended to regularly inspect the appliance. To avoid a hazard do not use the appliance if power cord, power plug or appliance becomes damaged in any way. Return the entire appliance to the nearest authorised Breville Service Centre for examination and/or repair.
- Any maintenance other than cleaning should be performed at an authorised Breville Service Centre.
- This appliance is for household use only. Do not use this appliance for anything other than its intended use. Do not use in moving vehicles or boats. Do not use outdoors. Misuse may cause injury.
- The installation of a residual current device (safety switch) is recommended to provide additional safety protection when using electrical appliances. It is advisable that a safety switch with a rated residual operating current not exceeding 30mA be installed in the electrical circuit supplying the appliance. See your electrician for professional advice.

**SAVE THESE
INSTRUCTIONS**

KNOW

your Breville product

KNOW YOUR BREVILLE PRODUCT

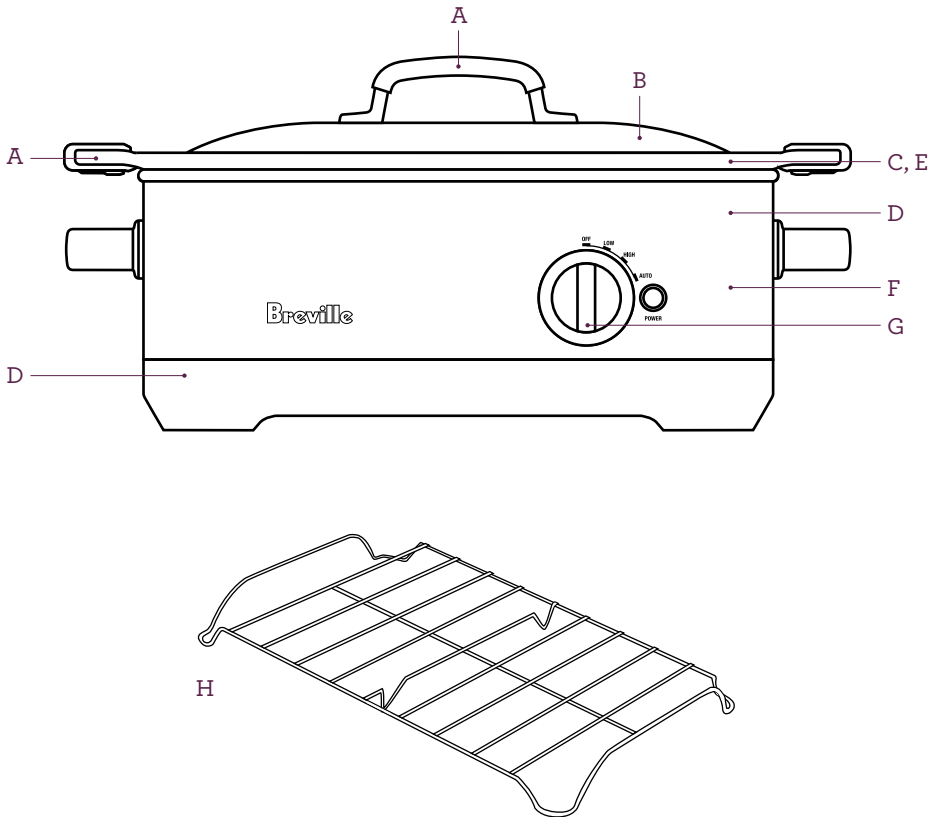

- A. **Silicon handle covers**
For heat protection.
- B. **Domed stainless steel lid**
Suitable for use in the oven.
- C. **Removable EasySear™ pan**
Designed for searing on the stovetop, slow cooking and roasting in the oven. Xylan® premium non-stick for easy cleaning.
- D. **Wrap around element (not shown)**
Ensures an even temperature throughout the cooking process.
- E. **Extra large 7 litre capacity**
For family sized meals.
- F. **Slow cooker base**
Premium brushed stainless design.
- G. **Control dial with AUTO setting**
For ease and simplicity.
- H. **Stainless steel rack**
For roasting.
- I. **Removable cord (not shown)**
For serving at the table and easy storage.

BEFORE FIRST USE

of your Breville product

BEFORE FIRST USE

Before first use, remove all promotional labels and packing materials and safely discard. Wash the removable EasySear™ pan and stainless steel lid in hot, soapy water, rinse and dry thoroughly. Wipe the inside and the outside of the stainless steel housing with a soft, damp cloth, then dry thoroughly.

HOW TO SEAR BEFORE SLOW COOKING

1. Remove the EasySear™ pan from slow cooker base and place onto a large burner or hotplate on the gas, electric or ceramic stovetop.

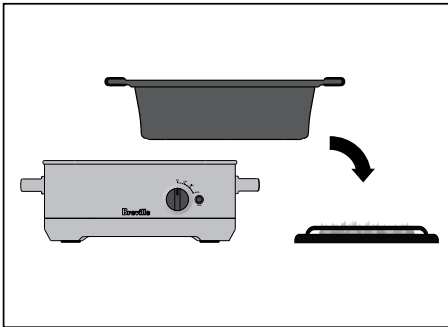

2. Coat the inside of the EasySear™ pan with oil or butter.

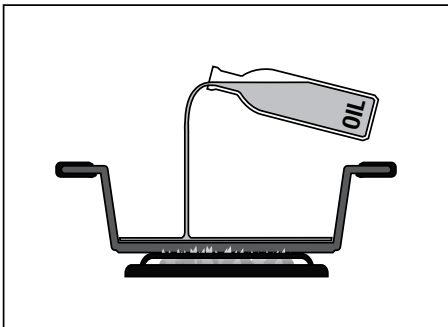

3. Heat EasySear™ pan on stovetop over medium to high heat.

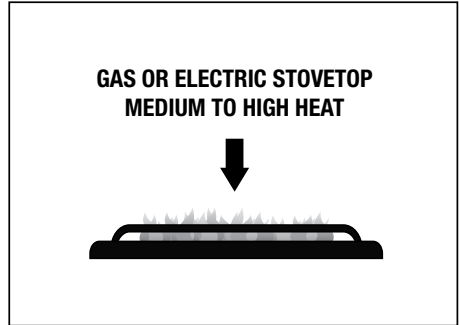

4. Place food to be seared into EasySear™ pan in batches.

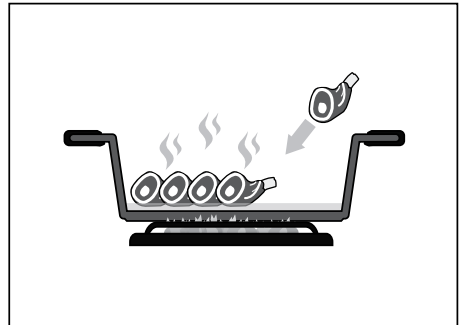

5. When finished searing, use oven mitts and carefully place EasySear™ pan back into slow cooker base. Proceed to How to Slow Cook section on this page.

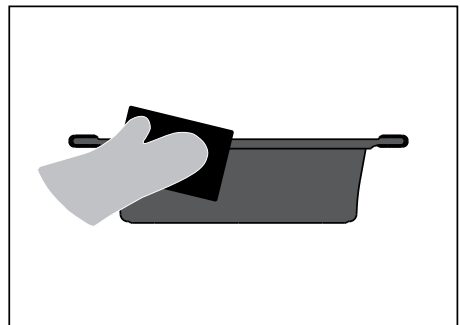

BEFORE FIRST USE

IMPORTANT

- EasySear™ pan is suitable for use on most electric, gas and ceramic stovetops, however it is not suitable for use on induction stovetops.
- The base of the EasySear™ pan may cause scratching on glass/ceramic or halogen cooktops.
- Stir food in the EasySear™ pan often, when cooking on the stovetop.
- Do not use metal utensils because they will scratch the non-stick coating on the EasySear™ pan.
- Do not heat EasySear™ pan when empty for prolonged periods of time as it may damage the cooking surface.
- Do not place EasySear™ pan in an oven that is hotter than 250°C.
- While silicone handles are heat resistant to 250°C (it is not recommended to use for extended periods above 200°C).

HOW TO SLOW COOK

1. Insert the EasySear™ pan which is either hot from searing on the stovetop or at room temperature into the slow cooker base. Add all ingredients into EasySear™ pan, ensuring denser foods are spread evenly across the bottom of the pan and not heaped to one side.

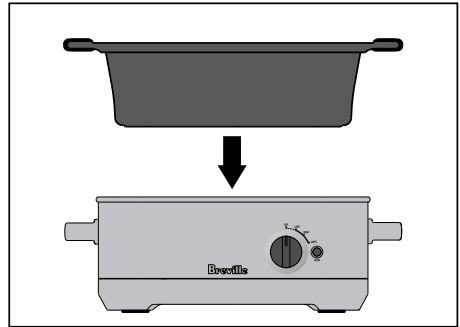

2. Place the stainless steel lid into position.

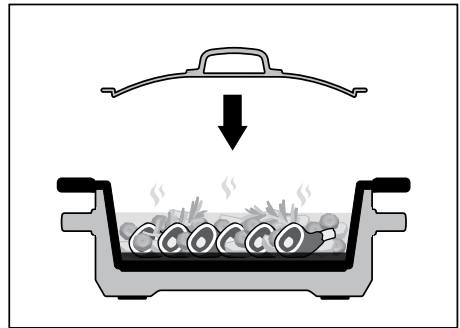

3. With the temperature control dial turned to the OFF position, insert the connector end of the power cord into the appliance inlet, plug the power cord into a 230V or 240V power outlet and switch the power on at the power outlet.

BEFORE FIRST USE

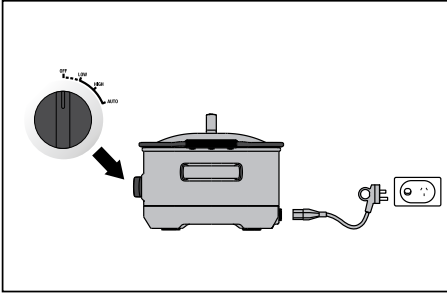

4. Turn the temperature control dial to the desired setting, or as recommended in a recipe. Go to www.breville.com.au for slow cooked recipe ideas and recipes in this instruction book.

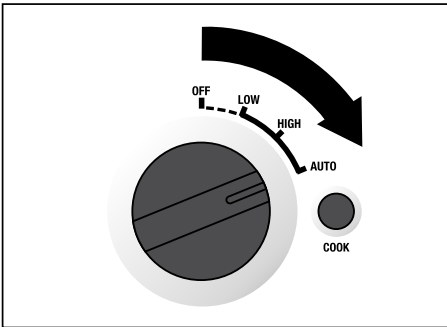

5. When cooking is complete, turn the temperature control dial to the OFF position, switch off at the power outlet, remove the power plug and then the connector end from the appliance inlet.

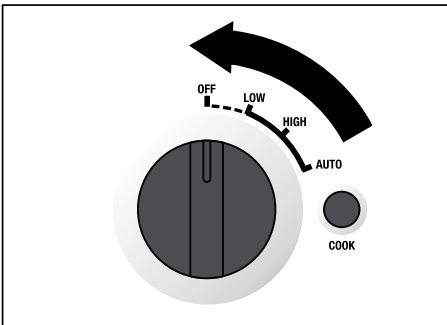

IMPORTANT

- Always use the slow cooker with EasySear™ pan on a dry, level surface.
- Never operate the slow cooker without the removable EasySear™ pan positioned in the slow cooker base.
- Never operate the slow cooker without food and liquids in the removable EasySear™ pan.
- Always have the stainless steel lid firmly in position on the removable EasySear™ pan throughout the operation of the slow cooker unless it is stated in a recipe to have it removed.
- Always use dry pot holders or oven mitts to remove the EasySear™ pan and the stainless steel lid when hot.
- While providing some protection the silicone handles will become hot during use, an oven mitt is recommended.
- Do not place the removable EasySear™ pan or stainless steel lid when hot on any surface that may be affected by heat.

IMPORTANT

Always lift and remove the stainless steel lid carefully using an oven mitt and angled away from yourself to avoid scalding from escaping steam.

IMPORTANT

Always use dry pot holders or oven mitts when handling EasySear™ pan or stainless steel lid.

A BEGINNER'S GUIDE TO SLOW COOKING

with your Breville product

The Breville Flavour Maker is designed specifically for flavour layering. A technique professional chefs use to enhance and deepen the taste of meals by using the same pan for browning onions, searing meats and creating casseroles, curries, soup, stock and bolognaise.

For this reason, Breville have now developed a Flavour Maker with a EasySear™ pan. Simply remove the EasySear™ pan from the slow cooker base and use on the gas, electric or ceramic stovetop to caramelize vegetables and sear meats before placing back into the slow cooker base and commencing the Slow Cook function.

Following is a guide to help simplify the process of slow cooking, allowing you to obtain optimum results from your slow cooker.

We have also included helpful hints for successful slow cooking. For recipes, go to www.breville.com.au and recipes in this instruction book.

PREPARING MEAT AND POULTRY

Select the leanest cuts when purchasing meat. Trim the meat or poultry of any visible fat. If possible, purchase chicken portions without the skin. Otherwise, the slow cooking process will result in extra liquid being formed from the fat as it melts.

For casserole type recipes, cut the meat into cubes, approximately 2.5cm to 3cm. Slow cooking allows less tender cuts of meat to be used. The bones can be left on meat or poultry if liked and will help to keep meat tender during cooking.

SUITABLE MEAT CUTS FOR SLOW COOKING

Beef	Chuck, skirt, round steak, boneless shin (Gravy) beef, bone-in-shin (Osso Bucco).
Lamb	Shanks, drumsticks (frenched shanks), neck chops, boned out forequarter or shoulder.
Veal	Diced leg, shoulder/ forequarter chops and steaks, neck chops, knuckle (Osso Bucco)
Pork	Leg steaks, diced belly, Diced shoulder, Boneless loin chops

PREPARING VEGETABLES

Vegetables should be cut into even-sized pieces to ensure more even cooking. Frozen vegetables must be thawed before adding to other foods cooking in the slow cooker with a EasySear™ pan.

PREPARING DRIED BEANS AND PULSES

If time permits, overnight soaking of dried beans and pulses is preferable. After soaking, drain and place in the slow cooker and cover with sufficient water to reach double their volume. Cook beans on the HIGH setting for 2 to 4 hours or until tender. Pre-soaked beans and pulses will cook a little faster.

SEARING AND BROWNING BEFORE SLOW COOKING

Searing and browning in the EasySear™ pan on the stovetop may take a little extra time and whilst not strictly necessary, the rewards are evident in the end result.

The EasySear™ pan keeps the heat stable and uniform allowing the meat to brown and form an even crust. Plus searing and browning seals in the moisture, intensifies the flavour and provides more tender results.

Once searing and browning is complete, return the EasySear™ pan to the slow cooker base with all the tasty caramelized ingredients inside.

USING THE TEMPERATURE CONTROL SETTINGS

This slow cooker has three settings: Low, High and Auto. Use the recommended guidelines below to determine cooking time and heat setting and use recipes in this instruction book. Dishes can be prepared well in advance of mealtime and cooking time regulated so that food is ready to serve at a convenient time.

A general rule of thumb for most slow cooked meat and vegetable recipes is:

SETTING COOKING TIME	
LOW	6 to 10 hours
HIGH	3 to 4 hours
AUTO	4 to 6 hours

Your favourite traditional recipes can also be easily adapted to this slow cooker. Simply halve the amount of liquid and increase the cooking time. The following is a guide to adjusting your favourite recipes.

NOTE

These times are approximate. Times can vary depending on ingredients and quantities in recipes

TRADITIONAL COOKING TIME	SLOW COOKER COOKING TIME (WITHOUT SEARING)		
	LOW	HIGH	AUTO
35 to 60 minutes	6 to 10 hrs	3 to 4 hrs	4 to 6 hrs
1 to 3 hours	8 to 10 hrs	4 to 6 hrs	6 to 8 hrs

TRADITIONAL COOKING TIME	SLOW COOKER COOKING TIME (WITH SEARING)		
	LOW	HIGH	AUTO
35 to 60 minutes	4 to 5 hrs	2 to 3 hrs	3 to 4 hrs
1 to 3 hours	5 to 6 hrs	3 to 4 hrs	4 to 5 hrs

COOKING TIMES (WITH SEARING)

When the EasySear™ pan is used for searing on the stovetop prior to being placed in the slow cooker, cooking times will be shortened slightly. Check for doneness intermittently during cooking.

NOTE

These cooking times are approximate only and times can vary depending on ingredients, quantities in recipes and whether the EasySear™ pan and its ingredients are hot from searing.

NOTE

High humidity, altitude, cold tap water, ingredients and minor fluctuations may slightly affect the cooking times in the slow cooker with EasySear™ pan.

LOW SETTING

The LOW setting gently simmers food for an extended period of time without overcooking or burning. No stirring is required when using this setting.

HIGH SETTING

The HIGH setting will cook food in approximately half the time required for the LOW setting. Some foods may boil when cooked on the High setting, so it may be necessary to add extra liquid. This will depend on the recipe and the amount of time in which it is cooked. Occasional stirring of stews and casseroles will improve flavour distribution.

The HIGH setting in this slow cooker cooks considerably faster than the AUTO or LOW settings and can be used if time is a constraint. Simply place your favourite meal on HIGH for 3 to 4 hours and you will have a cooked meal in a fraction of the time.

AUTO SETTING

The AUTO setting will begin cooking on HIGH and then will shift to Low after approximately 2 hours of cooking time for added ease and simplicity.

ROASTING IN THE SLOW COOKER

Roasting meats in the Flavour Maker creates tender, flavoursome results. The long, slow, covered cooking process breaks down and softens the connective and muscle tissue within the meat, making it easier to slice. Cheaper cuts of meat can be used to provide perfect results cooked by this method.

Meat will not brown during the slow cooking process, so for browner results sear in the EasySear™ pan on the stovetop first before placing back into the slow cooker base.

The addition of liquid is not required for roasting. Elevate the meat to be cooked on the provided stainless steel rack. This will assist in keeping the surface of the meat dry and free from any fat released throughout the cooking process.

SUITABLE MEAT CUTS FOR ROASTING

Beef	Blade, Rump, Rib Roast, Sirloin, Silverside, Topside.
Lamb	Leg, Mid Loin, Rack, Crown Roast, Shank, Shoulder, Mini Roasts.
Veal	Leg, Loin, Rack, Shoulder/Forequarter.
Pork	Loin, Neck, Leg, Racks (remove skin & fat).

POT ROASTING IN THE SLOW COOKER

The addition of liquid is required for pot roasting. Place sufficient liquid into the removable EasySear™ pan to cover up to a third of the meat. Meat will not brown during the pot roasting process, so for browner results sear in the EasySear™ pan on the stovetop first before placing back into the slow cooker base for pot roasting.

SUITABLE MEAT CUTS FOR POT ROASTING

Beef	Topside, Blade, Silverside Roasts, Rolled Brisket.
Lamb	Forequarter, Shank, Shoulder.
Veal	Shoulder/Forequarter.
Pork	Loin, Neck.

USING THE EASYSEAR™ PAN AS STAND ALONE COOKWARE

This slow cooker is equipped with a diecast removable EasySear™ pan to withstand temperature extremes. It can be used for browning and searing on a gas, electric or ceramic stovetop or as a traditional roasting pan for use in the oven.

The removable EasySear™ pan and stainless steel lid is safe for use on stovetops and in conventional ovens up to 250°C.

NOTE

We do not recommend to use the stainless steel lid in the oven. If it is used in an oven it may discolour.

NOTE

While silicone handles are heat resistant to 250°C, it is not recommended to use for extended periods above 200°C.

HINTS AND TIPS

for your new Breville product

HINTS AND TIPS

- Trim all visible fat from meat or poultry.
- If a recipe calls for browning the meat, it may be browned in the EasySear™ pan on the gas, electric or ceramic stovetop.
- Meat and poultry require at least 6 to 7 hours of cooking on LOW setting or 3 to 4 hours on HIGH setting.
- Ensure that the food or liquid to be cooked fills half to ¾ of the EasySear™ pan.
- If after cooking the liquid quantity is excessive, remove the lid and operate the slow cooker on the HIGH setting for 30 to 45 minutes or until the liquid reduces by the desired amount. Alternatively, the liquid can be thickened by adding a mixture of cornflour and water and cooking on HIGH setting without the lid until sauce has thickened.

DO'S

- Always thaw frozen meat and poultry before cooking.
- Use dry oven mitts when lifting the lid or removable EasySear™ pan after searing or slow cooking.
- Place the EasySear™ pan onto a heat proof mat if serving from the EasySear™ pan at the table.
- To keep foods warm for serving, turn control to the LOW setting until ready to serve.

DONT'S

- Do not operate the slow cooker without the EasySear™ pan in position, in the slow cooker base.
- Do not cook with frozen meats or poultry.
- Do not remove the stainless steel lid from the slow cooker unnecessarily as this will result in major heat loss.
- Stirring is not necessary when Slow Cooking. However, if cooking on the HIGH setting, stirring occasionally will help to distribute flavours throughout the recipe.
- Do not use HIGH setting if you intend on being away from home for more than 3 hours.

NEVER

- Place water or other liquids into slow cooker base.
- Immerse the slow cooker base, power cord, or power plug in water or any other liquid.
- Touch hot surfaces with bare hands.
- Deep fry in the EasySear™ pan.

CARE AND CLEANING

of your new Breville product

CARE AND CLEANING

- Before cleaning the Flavour Maker switch the temperature control dial to OFF, switch off at the power outlet, unplug from the power outlet and remove the connector end of the power cord from the appliance inlet.
- Remove EasySear™ pan and allow to cool completely.
- To remove stubborn, cooked-on foods in the removable EasySear™ pan, soften by filling $\frac{3}{4}$ with water, bring to a slow boil on medium heat on the stove top, add detergent and simmer for 15 minutes. Remove by lightly scrubbing with a soft nylon kitchen brush.
- The removable EasySear™ pan and stainless steel lid can be washed in the dishwasher. However, to maintain non-stick coating, it is recommended to wash EasySear™ pan in hot, soapy water using a mild household detergent. Rinse and dry thoroughly.
- Do not use abrasive cleaners, steel wool, or scouring pads as these can damage the surfaces and non-stick coating.
- To prevent damage to the appliance, do not use alkaline cleaning agents, use a soft cloth and a mild detergent.
- The brushed stainless steel slow cooker base can be wiped over with a soft, damp cloth and then dried thoroughly.

IMPORTANT

Do not use alkaline cleaning agents, use a soft cloth and a mild detergent.

IMPORTANT

Do not use abrasive cleaners, steel wool or scouring pads.

IMPORTANT

Do not immerse slow cooker base or power cord in water or any other liquid as they may cause electrocution.

IMPORTANT

Ensure removable EasySear™ pan is correctly positioned in the base before you commence cooking.

RECIPES

for your new Breville product

FENNEL AND WHITE BEAN SOUP

Serves 8 to 10

INGREDIENTS

375g dried white beans
 30g butter
 1 Tablespoon olive oil
 3 leeks, thinly sliced
 4 cloves garlic, finely chopped
 4 large bulbs fennel, halved and sliced
 8 cups/2 litres vegetable or chicken stock
 ½ teaspoon ground white pepper
 Sea salt
 Wedges of fresh lemon

METHOD**White Bean Preparation**

1. Place dried beans into a large bowl, cover with cold water and soak overnight. Rinse and drain well.

Searing on the stovetop with EasySear™ pan

2. Place EasySear™ pan onto stovetop and preheat for 2 to 3 minutes, add butter and oil, heat a further 1 minute or until butter has melted.
3. Add leeks and garlic and sauté until leeks have softened slightly, about 2 to 3 minutes, stirring occasionally.
4. Add fennel and cook for 3 to 4 minutes or until fennel has softened slightly, stirring occasionally.

Slow Cooking

5. Place EasySear™ pan back into slow cooker base.
6. Add drained beans, stock and pepper, mixing well.
7. Cover with lid, turn temperature control dial to AUTO setting. Cook for 5 to 6 hours or until beans are very tender.
8. Season soup with salt and serve with wedges of lemon.

TIP

Great Northern Beans were used in this recipe but any dried white beans can be used.

Setting Variation: Use the LOW setting and cook for 8 to 10 hours or the HIGH setting for 4 to 5 hours.

SPICY KUMERA SOUP

Serves 8 to 10

INGREDIENTS

2 Tablespoons oil
 3 large onions, chopped
 1 Tablespoon Cajun spice
 ½ teaspoon ground fennel seeds
 1 teaspoon ground cumin
 6 cups/1½ litres vegetable or chicken stock
 2kg kumera (sweet potato), peeled and cut into small chunks
 Salt and pepper
 1 cup sour cream or natural yogurt
 Fresh tortillas

METHOD**Searing on the stovetop with EasySear™ pan**

1. Place EasySear™ pan onto stovetop and preheat for 2 to 3 minutes, add oil and heat a further 1 minute.
2. Add onions and sauté until onion has softened slightly, about 3 to 4 minutes, stirring occasionally
3. Add Cajun spice, ground fennel seeds and ground cumin, sauté for 2 to 3 minutes or until spices are fragrant.

Slow Cooking

4. Place EasySear™ pan back into slow cooker base.
5. Add stock and sweet potato, mix well.
6. Cover with lid, turn temperature control dial to HIGH setting. Cook for 2 to 3 hours or until sweet potato is very soft.
7. Turn dial to OFF and turn slow cooker off at power outlet, remove power plug from power outlet.
8. Using a non scratch potato masher gently mash sweet potato until well broken up. Season soup with salt and pepper.
9. Serve soup with a spoonful of sour cream or natural yogurt and fresh warmed tortillas.

Setting Variation: Use the LOW setting and cook for 6 to 7 hours or the AUTO setting for 4 to 5 hours.

PEA AND HAM SOUP

Serves 10

INGREDIENTS

750g split peas (green or yellow)
 1 Tablespoon oil
 30g butter
 3 large onions, finely chopped
 4 large carrots, diced
 4 sticks celery, diced
 8 cups/2 litres water
 1 kg ham bones
 4 bay leaves
 8 to 10 fresh sage leaves
 Sea salt and freshly ground pepper

METHOD**Split Pea Preparation**

1. Place split peas into a large bowl, cover with cold water and soak overnight. Rinse and drain well.

Searing on the stovetop with EasySear™ pan

2. Place EasySear™ pan onto stovetop and preheat for 2 to 3 minutes, add oil and butter, heat a further 1 minute or until butter has melted.
3. Add onions, carrots and celery, sauté until onion has softened slightly, about 4 to 5 minutes, stirring occasionally.

Slow Cooking

4. Place EasySear™ pan back into slow cooker base.
5. Add water, split peas, ham bones, bay leaves and sage leaves. Mix well and cover with lid
6. Turn temperature control dial to AUTO setting, cook for 7 to 8 hours or until peas are very soft
7. Remove ham bones and cut any meat from bone, chop ham finely. Return chopped ham to soup.
8. Season soup with salt and pepper and serve with fresh crusty bread.

Setting Variation: Use the HIGH setting and cook for 4 to 5 hours or LOW setting for 8 to 10 hours.

SIMPLE VEGETABLE AND LENTIL SOUP

Serves 8 to 10

INGREDIENTS

- 2 Tablespoons oil
- 3 large onions, chopped
- 4 cloves garlic, finely chopped
- 1 kg smoked ribs or bacon bones
- 4 sticks celery, finely chopped
- 5 carrots, diced
- 1 medium sweet potato (400g), peeled and diced
- 12 cups/3 litres chicken or vegetable stock
- 2 cups/400g red lentils, rinsed and drained
- 1 cup/220g green lentils, rinsed and drained
- Salt and freshly ground black pepper
- 1 cup chopped fresh coriander or parsley

METHOD

Searing on the stovetop with EasySear™ pan

1. Place EasySear™ pan onto stovetop and preheat for 2 to 3 minutes, add oil, heat for a further 1 minute.
2. Add onions and garlic, sauté for 5 minutes or until onion has softened, stirring occasionally.
3. Add smoked ribs, celery and carrots, cook for 3 to 4 minutes, stirring occasionally.

Slow Cooking

4. Place EasySear™ pan back into slow cooker base.
5. Add sweet potato, stock and lentils to pan, mixing well.
6. Cover with lid, turn the temperature control dial to HIGH setting and cook for 4 to 5 hours or until lentils are soft.
7. Season with salt and pepper, serve hot with chopped coriander or parsley.

TIP

For a spicier version of this soup add 1 Tablespoon of Moroccan Spice mix to the EasySear™ pan when sautéing onions and garlic.

Setting Variation: Use the LOW setting and cook for 8 to 10 hours or AUTO setting for, 5 to 6 hours or until lentils are soft.

CHICKPEA CURRY WITH SWEET POTATO

Serves 8

INGREDIENTS

- 500g dried chickpeas
- 2 Tablespoons olive oil
- 2 large onions, finely chopped
- 4 cloves garlic, finely chopped
- 1 Tablespoon fresh chopped ginger
- 1 cinnamon stick
- 1 teaspoon ground chilli powder
- 3 teaspoons ground coriander
- 3 teaspoons ground cumin
- 1 Tablespoon brown mustard seeds
- 3 x 400g cans diced tomatoes
- 3½ cups/875ml vegetable or chicken stock
- 2 Tablespoons brown sugar, well packed
- Salt and pepper to taste
- 750g peeled sweet potato, cut into 2cm pieces
- 1 cup/250ml coconut milk, optional
- 1 cup chopped fresh coriander

METHOD

Chickpea Preparation

1. Place chick peas into a large bowl, cover with cold water, cover with plastic wrap and leave overnight to soak.

Searing on the stovetop with EasySear™ pan

2. Place EasySear™ pan onto stovetop and preheat for 2 to 3 minutes, add oil, heat for a further 1 minute.
3. Add onions, garlic and ginger, sauté for 5 minutes or until onion has softened, stirring occasionally.
4. Add all spices and sauté for 3 to 4 minutes or until spices are fragrant, stirring occasionally.
5. Add diced tomatoes, stock, brown sugar, salt and pepper. Bring to the boil.

Slow Cooking

6. Place EasySear™ pan back into slow cooker base.
7. Rinse chick peas well under cold running water, Drain, add to EasySear™ pan, stirring well.
8. Cover with lid, turn temperature control dial to HIGH setting. Cook for 2 to 4 hours or until chickpeas are tender.
9. Add sweet potato and mix well. Cover with lid and cook a further 1 to 2 hours or until and sweet potato is cooked.
10. Just before serving stir through coconut milk and chopped coriander.

Setting Variation: Use the LOW setting and cook for 8 to 10 hours, or AUTO setting for 5 to 6 hours and add sweet potato in the last 2 hours of cooking time.

INDIAN STYLE PUMPKIN WITH YOGURT

Serves 10 to 12

INGREDIENTS

- 2½ kg pumpkin
- 2 Tablespoons oil
- 1 large onion, chopped
- 4 cloves garlic, finely chopped
- 2 Tablespoons fresh chopped ginger
- 2 small red chillies, finely chopped
- 1 Tablespoon ground coriander
- ⅓ cup brown sugar
- 1 teaspoon salt
- 700g bottle tomato passata
- 400g can diced tomatoes, pureed
- 500g green beans, trimmed

Yogurt Sauce:

- 1½ cups natural yogurt
- ¾ cup chopped fresh mint
- ½ teaspoon ground cumin
- Salt and pepper

METHOD

Pumpkin Preparation

1. Wash and dry pumpkin and cut into large wedges, leaving skin on. Remove seeds and discard.

Searing on the stovetop with EasySear™ pan

2. Place EasySear™ pan onto stovetop and preheat for 2 to 3 minutes, add oil, heat a further 1 minute.
3. Add onion, garlic, ginger, chillies and coriander and sauté until light golden brown, about 4 to 5 minutes, stirring occasionally.
4. Add sugar, salt, tomato passata and pureed tomatoes, mixing well.

Slow Cooking

5. Place EasySear™ pan into slow cooker base. Place pumpkin pieces into EasySear™ pan, turn to coat in the sauce.
6. Cover with lid, turn temperature control dial to AUTO setting. Cook for 3 to 3½ hours or until pumpkin is almost cooked, but still firm in centre.
7. Add beans to EasySear™ pan, cover with lid, cook for a further 20 to 30 minutes or until beans are just cooked and pumpkin is tender.
8. Yogurt Sauce: Mix together yogurt, mint and cumin. Season with salt and pepper.
9. Serve pumpkin and beans with a spoonful of Yogurt sauce.

TIP

Any variety of pumpkin works well in this recipe.

Setting Variation: Use the LOW setting and cook for approx 4 to 6 hours or HIGH setting for 2 to 2½ hours.

CAPONATA

Serves 10 to 12

INGREDIENTS

- 1.5kg eggplant, trimmed and cut into large 3 to 4cm chunks
- 2 Tablespoons salt
- ¼ cup olive oil
- 3 large onions, chopped
- 5 cloves garlic, finely chopped
- 3 red capsicum, cut into 3cm chunks
- 3 green capsicum, cut into 3cm chunks
- 4 sticks celery, thickly sliced
- 2 x 400g cans diced tomatoes
- ½ cup/125ml white wine vinegar
- 2 Tablespoons brown sugar, well packed
- 1 cup pitted halved green olives
- ⅓ cup capers, rinsed and drained

METHOD

Eggplant Preparation

1. Place eggplant chunks into a large colander, sprinkle with salt mixing well. Leave to drain for 30 minutes.
2. Rinse eggplant well with running water, drain and pat dry.

Searing on the stovetop with EasySear™ pan

3. Place EasySear™ pan onto stovetop and preheat for 2 to 3 minutes, add oil and heat a further 1 minute.
4. Add onions and garlic, sauté until onion has softened slightly, about 3 to 4 minutes, stirring occasionally.
5. Add capsicum and celery, sauté for 3 minutes. Add eggplant and mix well.

Slow Cooking

6. Place EasySear™ pan back into slow cooker base.
7. Add tomatoes, vinegar, brown sugar, olives and capers, mix lightly through.
8. Cover with lid, turn temperature control dial to AUTO setting and cook for 3 to 4 hours or until eggplant is tender. Season to taste with salt.
9. Serve as an accompaniment to meat or chicken or on its own with crusty bread.

Setting Variation: Use the LOW setting and cook for 4 to 6 hours or HIGH setting for 3 to 3½ hours.

SRI LANKAN FISH CURRY

Serves 10 to 12

INGREDIENTS

3 Tablespoons oil
 4 onions, finely chopped
 8 cloves garlic, finely chopped
 ½ cup finely chopped fresh ginger
 4 small red chillies, seeds removed and finely chopped
 2 Tablespoons ground coriander
 2 Tablespoons black mustard seeds
 3 teaspoons ground turmeric
 20 fresh curry leaves
 2 kg fresh ripe tomatoes, chopped into 2cm chunks
 270ml can coconut cream
 2kg thick firm white fish fillets cut into 3cm chunks, bones and skin removed
 Juice of 1 lemon
 2 teaspoons sea salt and pepper to taste
 Lemon wedges to serve
 Extra chopped fresh coriander to serve

METHOD

Searing on the stovetop with EasySear™ pan

1. Place EasySear™ pan onto stovetop and preheat for 2 to 3 minutes, add oil, heat a further 1 minute.
2. Add onions, garlic, ginger and chillies, sauté for 5 minutes or until onions have softened, stirring occasionally.
3. Add ground coriander, mustard seeds, turmeric and curry leaves, cook for 3 minutes or until spices are fragrant, stirring occasionally.
4. Stir through tomatoes.

Slow Cooking

5. Place EasySear™ pan back into slow cooker base.
6. Cover with lid, turn temperature control dial to LOW setting. Cook for 3 to 4 hours or until tomatoes are well cooked and softened.
7. Before serving, stir through coconut cream and fish pieces and mix well. Cover with lid and continue cooking for a further 2 to 2½ hours or until fish is cooked. Stir through lemon juice and season to taste with salt and pepper.
8. Serve with lemon wedges and extra fresh coriander.

Setting Variation: Use the HIGH setting and cook sauce for 2 to 2½ hours or AUTO setting for 3 to 4 hours, add fish in last 2 to 2½ hours of cooking time.

CHICKEN WITH SHALLOTS AND GARLIC

Serves 8 to 10

INGREDIENTS

3 kg chicken pieces (Thigh cutlets, drumsticks, chicken breast bone-in)

½ teaspoon salt

½ teaspoon ground white pepper

2 Tablespoons oil

20g butter

2 heads garlic, peeled and separated

300g eshallots peeled

2 cups/500ml dry white wine

1½ cups/375ml cooled chicken stock

2 Tablespoons cornflour

2 Tablespoons chopped fresh thyme leaves

Sprinkle chicken pieces with salt and pepper

METHOD

Searing on the stovetop with EasySear™ pan

1. Place EasySear™ pan onto stovetop and heat for 2 to 3 minutes, add oil, heat 1 minute.
2. Add half the chicken and cook over a medium heat until golden brown all over.
3. Remove chicken from EasySear™ pan, set aside.
4. Add remaining chicken to EasySear™ pan and repeat.
5. Add butter, garlic and eshallots, sauté until golden brown, about 6 to 8 minutes, stirring occasionally.
6. Pour in wine and bring to the boil. Simmer for 2 minutes. Remove EasySear™ pan from heat.

Slow Cooking

7. Place EasySear™ pan back into slow cooker base.
8. Mix cooled chicken stock and cornflour together, pour this mixture into pan. Add chicken pieces, mix well and cover with lid.
9. Turn the temperature control dial to AUTO setting. Cook for 4 to 5 hours or until chicken is fully cooked.
10. Stir through fresh thyme leaves, season to taste with salt and pepper.

Setting Variation: Use the LOW setting and cook for 5 to 6 hours or HIGH setting for 3 to 4 hours.

SPICED SOY CHICKEN

Serves 8

INGREDIENTS

- 2 Tablespoons oil
- 3kg chicken thigh cutlets, skin removed
- 1 cup/250ml salt reduced soy sauce
- 1 cup/250ml Shao hsing (Chinese Cooking Wine) or dry sherry
- 4 cloves garlic, finely chopped
- ¼ cup chopped fresh ginger
- 4 star anise
- 2 cinnamon sticks
- 2 teaspoons sesame oil
- ¼ cup brown sugar, well packed
- 2 Tablespoons cornflour
- ½ cup/125ml water
- 3 green onions, very thinly sliced
- 2 red chillies, seeds removed and thinly sliced

METHOD**Searing on the stovetop with EasySear™ pan**

1. Place EasySear™ pan onto stovetop and preheat for 2 to 3 minutes, add oil and heat a further 1 minute.
2. Cook chicken pieces in batches until well browned on both sides, remove from pan. Remove EasySear™ pan from heat and drain off oil.

Slow Cooking

3. Place EasySear™ pan back into slow cooker base.
4. Add soy sauce, Shao hsing, garlic, ginger, star anise, cinnamon sticks, sesame oil and brown sugar, mix well.
5. Return chicken to pan and turn to coat all over in marinade. Cover with lid.
6. Turn temperature control dial to AUTO setting. Cook for 4 to 5 hours or until chicken is cooked, turning once during cooking if possible.
7. Remove chicken from EasySear™ pan and arrange pieces on a serving plate. Cover to keep warm.

EasySear™ pan back onto stovetop

8. Place EasySear™ pan back onto stovetop and bring mixture to the boil. Mix together cornflour and water, stir into EasySear™ pan, continue stirring until sauce boils and thickens.
9. Serve chicken with the marinade spooned over and top with green onions and chillies.

Setting Variation: Use the HIGH setting and cook for 3 to 4 hours or LOW setting for 5 to 6 hours.

CHICKEN MARSALA

Serves 8

INGREDIENTS

- 3 Tablespoons plain flour
- ½ teaspoon salt
- ½ teaspoon ground white pepper
- 12 chicken breast fillets (3kg)
- 2 Tablespoons oil
- 30g butter
- 250g eshallots, finely chopped
- 2½ cups Marsala
- 1 cup/250ml chicken stock
- 2 Tablespoons cornflour
- Salt and pepper
- ½ cup finely chopped green onions

METHOD

Chicken Preparation

1. Mix together flour, salt and pepper. Coat each chicken breast fillet in the flour mixture shaking off excess.

Searing on the stovetop with EasySear™ pan

2. Place EasySear™ pan onto stovetop and preheat for 2 to 3 minutes, add oil, heat a further 1 minute.
3. Add chicken in batches and sauté until golden brown on both sides. Remove from pan.
4. Add butter and eshallots, cook for 3 to 4 minutes, or until eshallots are light golden brown, stirring occasionally.
5. Add marsala, bring to the boil. Set aside.

Slow Cooking

6. Place EasySear™ pan into slow cooker base.
7. Mix together cooled chicken stock and cornflour until smooth.
8. Add stock mixture and chicken fillets to pan, mix well turning chicken over in the sauce.
9. Cover with the lid. Turn the temperature control dial to LOW setting, cook for 4 to 5 hours or until chicken is cooked.
10. Season to taste with salt and pepper, top with finely chopped green onions.
11. Serve chicken with mashed potatoes or hot pasta and steamed vegetables.

Setting Variation: Use the AUTO setting and cook for 3½ to 4 hours or HIGH setting for 3 to 3½ hours.

CHICKEN WITH FRESH HERBS AND TOMATOES

Serves 8 to 10

INGREDIENTS

2kg chicken pieces, (thigh cutlets, half breasts with bone in) skin removed

Salt and freshly ground pepper

2 Tablespoons olive oil

1½ kg desiree or other potatoes, peeled and cut into large wedges

8 cloves garlic, peeled and halved

2 large chicken stock cubes

1 cup/250ml white wine

2 Tablespoons polenta

¼ cup fresh oregano leaves

2 Tablespoons fresh thyme leaves

1kg ripe roma tomatoes, quartered and seeds removed

1 cup grated pecorino cheese

METHOD

Chicken Preparation

1. Trim any excess fat from chicken pieces, sprinkle all over with salt and pepper.

Searing on the stovetop with EasySear™ pan

2. Place EasySear™ pan onto stovetop and preheat for 2 to 3 minutes, add oil and heat a further 1 minute.
3. Add chicken pieces in batches, cook until chicken is browned on both sides, remove from pan.
4. Add potatoes and garlic to pan and cook for 4 to 5 minutes, stirring occasionally.

Slow Cooking

5. Place EasySear™ pan back into slow cooker base.
6. Crumble stock cubes into wine and pour wine over potatoes.
7. Sprinkle polenta over potatoes and mix well.
8. Lay chicken pieces over potatoes and sprinkle over fresh herbs. Lay tomatoes over chicken. Sprinkle generously with salt and pepper.
9. Cover with the lid. Turn temperature control dial to LOW and cook for 6 hours or until chicken is cooked.
10. To serve sprinkle chicken with pecorino cheese and serve with fresh salad leaves.

Setting Variation: Use the AUTO setting and cook for 4 to 5 hours.

ROAST LEG LAMB

Serves 8

INGREDIENTS

- 2.5kg leg of lamb
- Sea salt and freshly ground black pepper
- 1 Tablespoon oil

METHOD

Searing on the stovetop with EasySear™ pan

1. Season lamb all over with salt and pepper.
2. Place EasySear™ pan onto stovetop and preheat for 2 to 3 minutes, add oil, heat a further 1 minute.
3. Add lamb and cook until golden brown all over. Remove from pan.

Slow Cooking

4. Place EasySear™ pan back into slow cooker base. Place the stainless steel rack provided into pan.
5. Place lamb into EasySear™ pan on top of the stainless steel rack.
6. Cover with lid, turn the temperature control dial to HIGH setting and cook for 1½ to 2 hours or until lamb is cooked to desired doneness, (lamb should be medium done after approx. 1½ hours).

TIP

Chunks of potatoes, sweet potato, pumpkin or whole onions can be added to EasySear™ pan for last 1 to 1½ hours of cooking time. Toss vegetables in a little olive oil before adding to pan.

Setting Variation: Use the AUTO setting and cook for 4 to 4½ hours or LOW setting for 6 to 7 hours.

LAMB SHANKS BRAISED IN CHAR SUI SAUCE

Serves 8

INGREDIENTS

- 8 lamb shanks (approx 2½ kg)
- 2 Tablespoons plain flour
- 2 Tablespoons oil
- 1 large onion, finely chopped
- 4 cloves garlic, finely chopped
- 2 to 3 Tablespoons finely chopped fresh ginger
- 2 small red chillies
- 3 cups/750ml chicken stock
- ¾ cup/175ml Char Sui sauce
- ⅓ cup/90ml Hoi Sin sauce
- 2 Tablespoons soy sauce

METHOD

Lamb Preparation

1. Coat each lamb shank in flour shaking off excess.

Searing on the stovetop with EasySear™ pan

2. Place EasySear™ pan onto stovetop and preheat for 2 to 3 minutes, add oil, heat a further 1 minute.
3. Add lamb shanks in batches and cook until golden brown all over sides, Remove from pan.
4. Add onion, garlic, ginger and chillies to EasySear™ pan and sauté for 3 to 4 minutes or until onions and garlic are light golden brown.
5. Add chicken stock, Char Sui sauce, Hoi Sin sauce and soy sauce, mixing well.

Slow Cooking

6. Place EasySear™ pan into slow cooker base.
7. Add lamb shanks and turn to coat all over in sauce. Cover with lid, turn temperature control dial to AUTO setting. Cook for 4 to 6 hours or until lamb is very tender.
8. Remove lamb shanks from pan and set aside, keep warm.

EasySear™ pan on stovetop

9. Place EasySear™ pan back onto stovetop and bring sauce to the boil. Boil uncovered for 5 to 6 minutes or until sauce has thickened slightly, stirring occasionally.
10. Serve lamb shanks on steamed rice or potato mash with sauce spooned over.

Setting Variation: Use the LOW setting and cook for 6 to 8 hours.

NOTE

We do not recommend using the HIGH or AUTO setting for this recipe as lamb shanks should be cooked for an extended time for the most tender results.

LAMB KORMA

Serves 8 to 10

INGREDIENTS

- 2 Tablespoons oil
- 4 large onions, finely chopped
- 5 cloves garlic, finely chopped
- ¼ cup finely chopped fresh ginger
- ½ cup ground almonds
- 4 dried whole red chillies
- 1 Tablespoon ground coriander
- 1 ½ teaspoons ground turmeric
- 1 Tablespoon ground cumin
- ½ teaspoon ground cardamom seeds
- 2 cinnamon sticks
- 3 kg cubed lamb
- 1 cup natural yogurt
- 2 x 410g cans tomato puree
- 1 teaspoon salt
- Extra 1 cup natural yogurt
- 4 to 6 tomatoes, diced
- 1 cup chopped fresh coriander

METHOD

Searing on the stovetop with EasySear™ pan

1. Place EasySear™ pan onto stovetop and preheat for 2 to 3 minutes, add oil and heat a further 1 minute.
2. Add onions, garlic and ginger, sauté until onion has softened slightly, about 5 to 6 minutes, stirring occasionally.
3. Add ground almonds, chillies, ground coriander, ground turmeric, ground cumin, ground cardamom and cinnamon sticks. Cook until spices are fragrant, about 3 minutes, stirring.
4. Add lamb and mix well, cook until lamb has changed colour all over, about 5 minutes, stirring occasionally.

Slow Cooking

5. Place EasySear™ pan into slow cooker base.
6. Add yogurt, tomato puree and salt, mix well.
7. Cover with lid and turn temperature control dial to LOW setting, cook for 6 to 8 hours or until lamb is tender.
8. Serve with extra yogurt and chopped coriander and tomatoes.

Setting Variation: Use the AUTO setting and cook for approx 4 to 5 hours.

NOTE

We do not recommend using the HIGH or AUTO setting for this recipe as lamb korma should be cooked for an extended time for the most tender results.

OSSO BUCCO

Serves 8 to 10

INGREDIENTS

- ¼ cup plain flour
- Salt and pepper
- 2½ kg veal shanks, cut into 4cm thick pieces
- 3 Tablespoons oil
- 20g butter
- 4 large onions, chopped
- 6 cloves garlic, finely chopped
- 4 large carrots, diced
- 4 sticks celery, diced
- 3 cups/750ml white wine
- 2 beef stock cubes
- 700g bottle tomato passata
- 3 bay leaves

Gremolata:

- 4 cloves garlic, finely chopped
- Finely grated rind of 1 lemon
- ½ cup chopped fresh parsley

METHOD**Veal Preparation**

1. Mix together flour, salt and pepper. Coat pieces of veal in the flour mixture, shaking off excess.

Searing on the stovetop with EasySear™ pan

2. Place EasySear™ pan onto stovetop and preheat for 2 to 3 minutes, add 2 Tablespoons of the oil and butter, heat a further 1 minute or until butter is melted.
3. Add veal in batches and sauté until golden brown on both sides, adding extra oil to pan if necessary. Remove from pan when browned.
4. Add 1 Tablespoon oil to pan, add onions and garlic, sauté until onion has softened slightly, stirring occasionally.

5. Add carrots and celery, sauté for 3 to 4 minutes, stirring occasionally.
6. Add wine and stock cubes and bring to the boil.

Slow Cooking

7. Place EasySear™ pan back into slow cooker base.
8. Add tomato passata and bay leaves, mix well.
9. Add veal and turn to coat all over in sauce.
10. Cover with lid, turn temperature control dial to LOW setting for 6 to 7 hours or until veal is tender.
11. Mix together all Gremolata ingredients.
12. Serve Osso Bucco sprinkled with Gremolata.

Setting Variation: Use the AUTO setting and cook for 5 to 6 hours or on HIGH for 4 to 4½ hours.

BEEF BOURGIGNON

Serves 10 to 12

INGREDIENTS

2 stems sage leaves
 8 stems fresh thyme leaves
 2½kg gravy beef, cut into 3cm cubes
 ¼ cup plain flour
 Salt and freshly ground black pepper
 30g butter
 ¼ cup/ 60ml oil
 12 to 14 small pickling onions, peeled
 5 cloves garlic, finely chopped
 200g speck or slab bacon, diced
 500g button mushrooms, trimmed
 ⅓ cup tomato paste
 3 cups/750ml red wine
 2 cups/500ml beef stock
 2 bay leaves

METHOD**Beef Preparation**

1. Tie sage and thyme stems together firmly with cooking string.
2. Coat beef cubes in flour, salt and pepper.

Searing on the stovetop with EasySear™ pan

3. Place EasySear™ pan onto stovetop and preheat for 3 minutes, add half the butter and 1 Tablespoon of the oil, heat a further 1 minute or until butter is melted.
4. Add a quarter of the beef cubes and cook until golden brown, remove from pan and set aside. Add a little more of the oil and butter if necessary and repeat until all beef is browned. Remove from pan.
5. Add 1 Tablespoon oil to EasySear™ pan, add onions, garlic and speck or bacon and cook for about 4 to 5 minutes or until garlic is softened slightly and onions are lightly browned, stirring occasionally.
6. Add mushrooms and tomato paste and cook for 1 minute, stirring occasionally.

Slow Cooking

7. Place EasySear™ pan back into slow cooker base.
8. Stir in red wine, stock, beef, sage and thyme bundle and bay leaves, mix well.
9. Cover with lid, turn the temperature control dial to AUTO setting and cook for 5 to 6 hours or until beef is tender. Remove bay leaves, sage and thyme bundle and discard. Season to taste with salt and pepper.
10. Serve with Potato or Parsnip Mash.

Setting Variation: Use the LOW setting and cook for 7 to 8 hours or HIGH setting for 4 to 4½ hours.

MEATBALLS WITH ITALIAN SAUCE

Serves 8

INGREDIENTS**Meatballs**

1½kg mince (use a mixture of pork, veal or beef mince)
 2 onions, finely chopped
 4 cloves garlic, finely chopped
 1 cup fresh white breadcrumbs
 1 cup grated parmesan cheese
 1 cup finely chopped Italian parsley
 2 Tablespoons chopped fresh oregano
 Salt and pepper to taste

Tomato Sauce

2 Tablespoons olive oil
 2 large onions, finely chopped
 4 cloves garlic, finely chopped
 1 red capsicum, finely chopped
 1 cup/250ml dry white wine
 3 x 400g cans diced tomatoes
 1 cup/ 250ml beef stock
 ½ cup tomato paste
 1 Tablespoon brown sugar
 10 fresh basil leaves
 salt and pepper to taste
 Extra parmesan cheese to serve

METHOD**Meatball Preparation**

1. Mix all meatball ingredients together until well combined. Roll into small balls, cover and set aside.

Searing on the stovetop with EasySear™ pan

2. Place EasySear™ pan onto stovetop and preheat for 2 to 3 minutes, add oil, heat for a further 1 minute.
3. Add onions, garlic and red capsicum, sauté for 6 to 8 minutes or until onion has softened, stirring occasionally.
4. Add wine, bring to the boil and simmer until almost all liquid is gone, about 3 to 4 minutes.
5. Add canned tomatoes, beef stock, tomato paste, brown sugar and basil leaves. Season well with salt and pepper.

Slow Cooking

6. Place EasySear™ pan back into slow cooker base.
7. Place meatballs gently into EasySear™ pan, turn gently to coat all over in sauce.
8. Cover with lid, turn temperature control dial to LOW setting. Cook for 6 to 8 hours or until meatballs are cooked.
9. Serve meatballs and sauce with hot cooked pasta and extra grated parmesan cheese.

Setting Variation: Use the HIGH setting and cook for 3 to 4 hours or AUTO setting for 4 to 5 hours.

PASTA BOLOGNESE

Serves 10 to 12

INGREDIENTS

- 1/3 cup olive oil
- 2 1/2 kg beef or pork mince
- 4 onions, finely chopped
- 5 cloves garlic, finely chopped
- 4 carrots, finely chopped
- 4 sticks celery, finely chopped
- 1 cup/250ml red wine
- 2 1/2 cups/625ml beef stock
- 2 x 700g bottles tomato passata
- 1/2 cup tomato paste
- 1 Tablespoon brown sugar
- 2 Tablespoons chopped fresh oregano
- Salt and freshly ground black pepper to taste

METHOD**Searing on the stovetop with EasySear™ pan**

1. Place EasySear™ pan onto stovetop and preheat for 2 to 3 minutes, add 1 Tablespoon of the oil, heat a further 1 minute.
2. Cook mince in batches until well browned and crumbly, adding more oil if necessary, Remove from pan.
3. Add 2 Tablespoons of the oil to pan, add onions, garlic, carrots and celery and sauté for 5 to 6 minutes or until vegetables have softened slightly, stirring occasionally.
4. Add wine, bring to the boil and simmer until almost all liquid is gone, about 3 minutes.
5. Add browned mince, beef stock, tomato passata, tomato paste, brown sugar, oregano, salt and pepper, mix well.

Slow Cooking

6. Place EasySear™ pan back into slow cooker base and cover with lid.
7. Turn temperature control dial to LOW setting. Cook for 6 to 8 hours.
8. Serve with hot cooked spaghetti, sprinkled with chopped parsley and parmesan or pecorino cheese.

Setting Variation: Use the HIGH setting and cook for 3 to 4 hours or AUTO setting for 4 to 5 hours.

CORNED BEEF

Serves 6 to 8

INGREDIENTS

2–3kg piece of corned beef

12 cups/3 litres water

2 onions, quartered

¼ cup brown sugar, well packed

1 Tablespoon black peppercorns

3 bay leaves

Several sprigs of fresh herbs (parsley, thyme, sage, rosemary)

METHOD

Slow Cooking

1. Place EasySear™ pan into slow cooker base. Place corned beef into pan.
2. Add all other ingredients, making sure that water almost or fully covers beef.
3. Cover with lid, turn the temperature control dial to LOW setting. Cook for 7 to 8 hours or until corned beef is tender.
4. Remove corned beef from EasySear™ pan, allow to stand for 5 to 10 minutes.
5. Slice and serve with onion sauce and steamed vegetables.

NOTE

We do not recommend the HIGH or AUTO setting for this recipe as it should be cooked for an extended time for the most tender results.

RED CURRY OF BEEF

Serves 10 to 12

INGREDIENTS

- 2 Tablespoons oil
- 2 large onions, chopped
- 6 cloves garlic, finely chopped
- ¼ cup finely chopped fresh ginger
- ¾ cup red curry paste
- 2 teaspoons shrimp paste (belacan)
- 3 kg chuck steak, cut into 3cm cubes
- 2 cups/500ml beefstock
- ½ cup fish sauce
- 310g can coconut milk
- 6 large carrots, thickly sliced or cut into batons
- 12 kaffir lime leaves
- 3 stalks lemongrass, cut into 10cm lengths
- 2 Tablespoons brown sugar well packed
- 2 teaspoons salt
- 225g can sliced bamboo shoots, well drained
- 4 tomatoes, diced
- 1 cup chopped fresh coriander leaves
- 2 red chillies, sliced (optional)

METHOD

Searing on the stovetop with EasySear™ pan

1. Place EasySear™ pan onto stovetop and preheat for 2 to 3 minutes, add oil, heat a further 1 minute.
2. Add onions, garlic and ginger and sauté for 3 to 4 minutes or until onions have softened slightly.
3. Add curry paste and shrimp paste and cook for 3 minutes or until curry paste is very fragrant, stirring occasionally.
4. Stir in chuck steak, cook for 5 to 6 minutes or until steak has begun to change colour and is well coated in the curry paste, stirring frequently.

Slow Cooking

5. Place EasySear™ pan back into slow cooker base.
6. Add beef stock, fish sauce, coconut milk, carrots, kaffir leaves and lemongrass, mix well.
7. Cover with lid, turn temperature control dial to AUTO setting and cook for 5 to 6 hours or until beef is tender.
8. Remove lemongrass and kaffir leaves and discard. Season with sugar and salt then stir in bamboo shoots, mix well.
9. Serve red curry topped with chopped tomato, coriander and extra chillies (optional).

Setting Variation: Use the LOW setting and cook for 7 to 8 hours or HIGH setting for 4 to 5 hours.

NOTE

Red curry pastes vary in spice/chilli heat, for a milder curry add less for a hotter curry add a little more.

BEEF POT ROAST

Serves 6 to 8

INGREDIENTS

- 2 kg piece bolar blade beef, whole
- 2 Tablespoons plain flour
- Salt and freshly ground black pepper
- 2 Tablespoons oil
- 20g butter
- 2 large onions, finely chopped
- 3 sticks celery, finely chopped
- Extra 2 Tablespoons plain flour
- 4 cups/1litre beef stock
- 2 bay leaves
- 4 to 6 sprigs fresh thyme
- 750g potatoes, peeled and quartered
- 5 to 6 carrots, cut into large chunks or thick slices
- 8 to 10 small white onions

METHOD

Beef Preparation

1. Coat beef in flour, salt and pepper.

Searing on the stovetop with EasySear™ pan

2. Place EasySear™ pan onto stovetop and preheat for 2 to 3 minutes, add oil and heat a further 1 minute.
3. Add beef and cook until well browned all over, remove from pan.
4. Add butter, onions and celery to pan and cook 3 to 4 minutes, stirring occasionally.
5. Add extra 2 tablespoons of flour to pan, mix well cook 1 minute.
6. Gradually add stock, stirring until sauce boils and thickens.

Slow Cooking

7. Place EasySear™ pan back into base of slow cooker.
8. Add beef, bay leaves and thyme, turn beef to coat all over in gravy.
9. Cover with lid, turn temperature control dial to LOW setting. Cook for 4 hours, turning once during cooking.
10. Add potatoes, carrots and small onions to pan mixing well. Cover with lid and continue cooking for a further 2 to 3 hours or until meat and vegetables are tender.

Setting Variation: Use the AUTO setting and cook for 5 to 6 hours or until beef is cooked (Add vegetables at approximately the last 2 hours of cooking time).

CARAMEL PUDDING WITH BUTTERSCOTCH SAUCE

Serves 6

INGREDIENTS

- 125g butter
- 1 cup/250ml milk
- $\frac{3}{4}$ cup/150g brown sugar, well packed
- 2 x 60g eggs, lightly beaten
- 2 teaspoons vanilla essence
- 2 cups/300g self raising flour
- 1 teaspoon baking powder

Butterscotch Sauce

- Extra 1 cup/200g brown sugar, well packed
- 2 Tablespoons golden syrup
- 1 cup/250ml boiling water

METHOD

1. Stir butter, milk and brown sugar together in a large saucepan over a low heat until butter has melted, do not boil. Remove from heat and allow to cool to lukewarm.
2. Add eggs and vanilla essence to milk mixture and whisk until well combined.
3. Sift together flour and baking powder in a large bowl, gradually whisk in milk mixture until batter is smooth.
4. Pour batter into a well greased deep 8 to 10 cup ovenproof dish (that fits comfortably into EasySear™ pan). Sprinkle over extra brown sugar. Drizzle golden syrup evenly over the surface.

NOTE

Ovenproof dish should not touch sides of pan.

5. Gently pour boiling water evenly over this mixture. Grease a large sheet of foil and secure over the top of dish to make a lid, allowing room for pudding to rise.

Slow Cooking

6. Place the EasySear™ pan into the base of slow cooker.
7. Place the stainless steel rack provided into EasySear™ pan.
8. Pour in 4 cups/1 litre of water. Place ovenproof dish onto the rack.
9. Cover with lid, turn temperature control dial to HIGH setting. Cook for 1½ to 2 hours or until top of pudding is cooked in centre.
10. Serve immediately with fresh cream or ice cream.

NOTE

Check water level during cooking adding extra boiling water to base of EasySear™ pan if necessary.

NOTE

We do not recommend to use LOW or AUTO setting for this recipe.

POACHED RHUBARB AND APPLE

Serves 8 to 10

INGREDIENTS

3 large bunches rhubarb stems, cut into 5cm lengths

12 large apples, peeled and cut into thick slices

1¼ cups/310ml water

1½ cups/300g sugar

METHOD

Slow Cooking

1. Place EasySear™ pan into base of slow cooker.
2. Place rhubarb, apples, water and sugar into EasySear™ pan, mix well.
3. Cover with lid, turn temperature control dial to LOW setting. Cook for 3 to 5 hours or until rhubarb is tender but still has some shape.
4. Serve hot or cold with fresh cream, custard or ice cream.

NOTE

This recipe is only suitable for the LOW setting due to the high sugar content.

TIP

Other fruits such as peaches, nectarines, pears can be poached in the slow cooker. Always use the LOW setting and make sure there is enough water or liquid to cover the base of the EasySear™ pan to at least 4cm deep. Add sugar to taste and the fruit to be poached. Cover with lid and cook until fruit is tender, but still has its shape. Turn fruit during cooking if possible.

