



*Pure Air.
Pure Comfort.*

**True HEPA Air Cleaner
with PLASMAWAVE® Technology
Use and Care Guide**



AUS-9500

CAUTION:

Read and follow all
safety rules and instructions
before operating this equipment.

TABLE OF CONTENTS

Warranty.....	2	Display Panel.....	7
Package Contents.....	2	Operation.....	8-9
Safety Instructions.....	3	Remote Control.....	10-11
Product Specifications.....	4	Care and Maintenance.....	12-14
Air Cleaner Features.....	4-5	Troubleshooting.....	15
Air Cleaner Set-Up.....	6		

WARRANTY

WINIX Air Cleaner 1 Year Limited Warranty

When installed, operated and maintained according to all instructions supplied with this product, Winix, at its option, will repair or replace the product if it fails because of a defect in material or workmanship, as determined by Winix. Proof of the purchase date must be verified before any warranty work will be completed. All warranty coverage applies for only one year from the date of purchase. This warranty will be null and void if the product is used for purposes other than home consumer purposes.

This warranty covers only defects in material and workmanship. WINIX will NOT pay for:

1. Expendable items that can wear out from normal use, including but not limited to filters and remote controls.
2. A service technician to instruct the user in correct product installation, operation or maintenance.
3. A service technician to clean or maintain this product.
4. Damage to or failure of this product if it is not installed, operated or maintained according to all instructions supplied with the product.
5. Damage to or failure of this product resulting from accident, abuse, misuse or use for other than its intended purpose.
6. Damage to or failure of this product caused by the use of detergents, cleaners, chemicals or utensils other than those recommended in all instructions supplied with the product.
7. Damage to or failure of parts or systems resulting from unauthorized modifications made to this product.

Disclaimer of implied warranties; Limitation of remedies

Customer's sole and exclusive remedy under this limited warranty shall be product repair as provided herein. Implied warranties, including warranties of merchantability or fitness for a particular purpose, are limited to one year or the shortest period allowed by law. WINIX shall not be liable for incidental or consequential damages. Some states and provinces do not allow the exclusion or limitation of incidental or consequential damages, or limitation on the duration of implied warranties of merchantability or fitness, so these exclusions or limitations may not apply to you.

PACKAGE CONTENTS

- Winix PLASMAWAVE™ Air Cleaner w/ Filter Cassette
- Remote Control (1 unit)
- Batteries (2 AA batteries)
- Use and Care Guide

SAFETY INSTRUCTIONS

Thank you for purchasing a Winix air cleaner. Please read this manual carefully before using. This product is for household use only.

IMPORTANT CAUTIONS FOR USING YOUR AIR CLEANER

WARNING: Follow the instructions in this manual to reduce the risk of electric shock, short circuit, and/or fire:

- Do not repair or modify the unit unless specifically recommended in this manual. All other repairs should be completed by a qualified technician.
- Do not use if the power cord or plug is damaged or the connection to the wall outlet is loose.
- Use AC 220~240V only.
- Do not damage, break, forcefully bend, pull, twist, bundle, coat, pinch, or place heavy objects on the power cord.
- Periodically remove dust from the power plug. This will reduce the chance that humidity will accumulate, which increases the risk of electric shock.
- If the power plug is damaged, it must be replaced by the manufacturer or a qualified technician.
- Remove the power plug from the outlet before cleaning the unit. When removing the power plug, grasp by holding the plug itself, never hold by the cord.
- Remove the power plug from the outlet when the unit is not in use.
- Do not handle the power plug with wet hands.
- Do not operate the unit when using indoor smoke-generating insecticides.
- Do not clean unit with benzene or paint thinner. Do not spray insecticides on the unit.
- Do not use the unit where it is humid or where the unit may get wet, such as in a bathroom.

- Do not insert fingers or foreign objects into the air intake or outlet.
- Do not use the unit near flammable gases. Do not use near cigarettes, incense, or other spark-creating items.
- Unit will not remove carbon monoxide emitted from heating appliances or other sources.

IMPORTANT INSTRUCTIONS FOR USING YOUR AIR CLEANER

- Do not block the intake or outlet vents.
- Do not use near hot objects, such as a stove. Do not use where the unit may come into contact with steam.
- Do not use the unit on its side.
- Keep away from products that generate oily residue, such as a deep fryer.
- Do not use detergent to clean the unit.
- Do not operate without a filter.
- Do not wash and reuse the True HEPA Filter.
- If the supply cord is damaged, it must be replaced by the manufacturer, its service agent or similarly qualified persons in order to avoid a hazard.”
- This appliance is not intended for use by person (including children) with reduced physical sensory or mental capabilities, or lack of experience and knowledge, unless they have been given supervision or instruction concerning use of the appliance by a person responsible for their safety.
- Children should be supervised to ensure that they do not play with the appliance.

PRODUCT SPECIFICATIONS

	AUS-9500
Room Area Served	284 sq. ft. (26sq. m.)
Power Supply	220~240V~ / 50,60Hz
Power Rate	Low 6W, Turbo 70W
Fan Speed	4 Speeds
Display	LED Digital
Control Type	Auto/Manual
Dust Sensor	Yes
Odor Sensor	Yes
Light Sensor	Yes
Timer	1, 4 and 8 hour(s)
Sleep Mode	Yes
Filters	1 Replaceable Cassette
Cleaning System	Anti-Bacterial Pre Filter 99.97% Efficient True HEPA Filter Mesh Activated Carbon Filter PLASMAWAVE® Technology
CADR	182/183/194 (Dust/Smoke/Pollen)
HEPA Filter	True HEPA 99.97%
Technology	PLASMAWAVE®
Color	Metallic Silver/White
Remote Control	Yes
Dimensions	42cms(W) X 25cms(D) X 55cms(H)
Weight	8.5 Kgs

AIR CLEANER FEATURES

NOTE: The features of your air cleaner may vary according to model.

- Ultra-Quiet Operation**
 This Winix air cleaner has a four-speed fan with ultra-quiet operation that is ideal for nighttime operation.
- Easy Maintenance**
 Winix air cleaners are simple and economical to maintain. For optimum performance, replace complete filter cassette when CHANGE FILTER indicator light is on.
- Smart Dust and Odor Sensors**
 The 9500 air cleaner is equipped with digital sensors that automatically monitor air quality. As dust or odor levels change, fan speeds will adjust automatically.
- Simple Operation**
 Winix air cleaners have a remote control and user-friendly display for your convenience.

- **Light Sensor**

Automatically activates Sleep mode when the room is darkened, to ensure continuously quiet and energy-efficient operation.

- **Sleep Mode**

When in SLEEP mode, the control panel will dim and the unit will operate quietly at the lowest fan speed.

- **Change Filter Alert**

Lets you know when it's time to replace the complete filter cassette.

- **Timer Setting**

Allows you to adjust operation to your preferences.

- **Programmable Remote Control**

Allows power on/off and fan speed adjustments from anywhere in the room.

- **Four-Speed Setting**

From LOW for quiet, energy-efficient operation to TURBO for the most effective cleaning.

FIVE-STAGE CLEANING

Air undergoes five separate processes before returning, freshened and cleaned, to the room.

- **Anti-Bacterial Pre-Filter**

This reusable filter collects large particles, pollen, pet hair, lint, etc to help extend the life and efficiency of the True HEPA Filter.

- **True HEPA Filter**

Captures 99.97% of particles and impurities as small as .3 microns.

- **Mesh**

Neutralizes bacteria oncontact.

- **Carbon Filter**

This activated natural carbon filter is three times more effective at trapping and neutralizing strong, hard to remove odors, including ammonia.

- **PLASMAWAVE®**

In the final stage of cleaning, Winix PLASMAWAVE® technology generates both positive and negative ions to create plasma clusters which instantly neutralize viruses, bacteria, chemical vapors and odors in the air.

PLASMAWAVE® can be turned on and off using the remote control, however we recommend leaving it on all the time.

FRONT SIDE

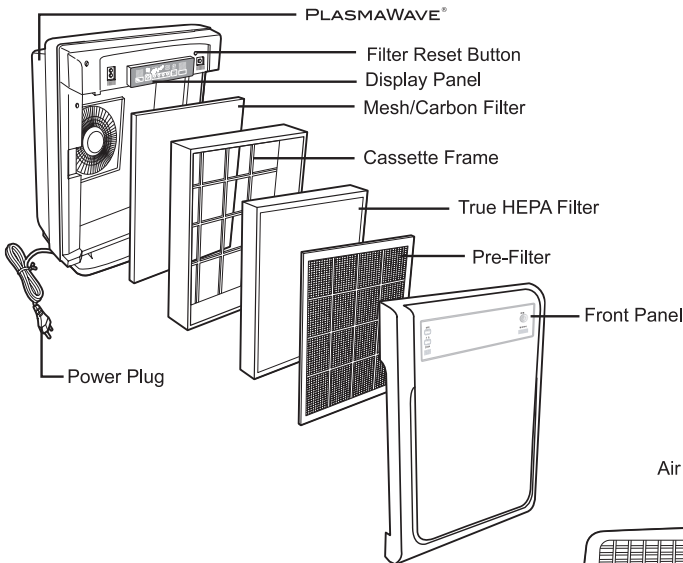

TOP SIDE

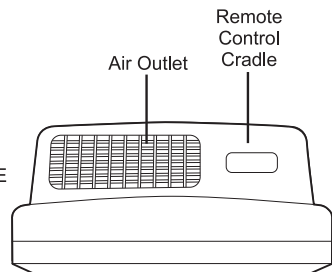

AIR CLEANER SET-UP

NOTE: Follow these instructions for best results.

- Place unit at least 200cms from equipment that emits electric waves such as televisions or radios.
- Place unit at least 60cms from the wall.
- Keep sensors away from drafty areas.
- Keep curtains away from sensors, as they may interfere with air intake/outlet.
- Place unit on a stable surface with plenty of air circulation.

1. Remove protective film from the control panel.

2. Remove the front panel by grasping the bottom outside edges and gently pulling toward you.



3. Pull out the filter cassette by grasping the tabs located on each side of the filter cassette.

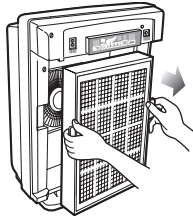

4. Remove the plastic wrap from the filter cassette.

5. Return the filter cassette into the main unit.

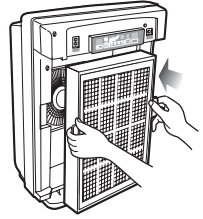

6. Replace the front panel by hooking the front panel on the top of the unit. Gently push the bottom of panel until it snaps into place.



7. Plug in the power cord to a wall outlet.

8. Press POWER button until short “beep” is heard.

For the first 4 minutes after turning the unit on, the dust and odor indicators will flash while the unit measures air quality.

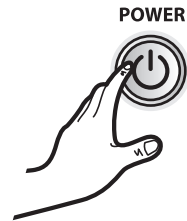

DISPLAY PANEL

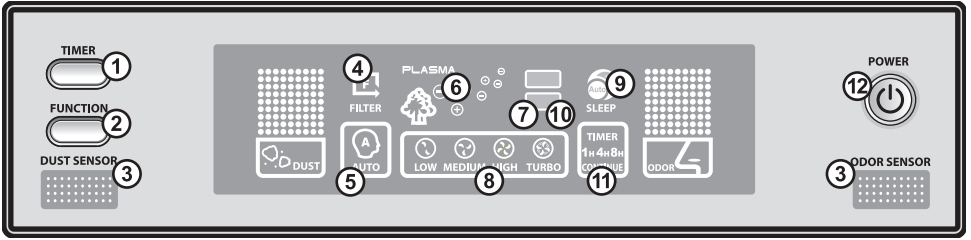

1. **TIMER** - Press the TIMER button once for 1 hour of operation; press the button a second time for 4 hours; press a third time for 8 hours. Pressing the TIMER button a fourth time returns to the Off Timer mode.
2. **FUNCTION** - Press the FUNCTION button once to set the unit to Auto. Continue to press the button for Sleep > Low > Medium > High > Return to Auto.
3. **DUST & ODOR SENSORS** - Automatically monitor air quality and adjust fan speed.
4. **CHANGE FILTER INDICATOR** - The indicator will signal when to replace the filter cassette.
5. **AUTO MODE** - The unit is set to default to Automatic operation when it is first turned on. Smart sensors will automatically sense the amount of impurities in the air, and adjust the fan speed accordingly.
6. **PLASMAWAVE[®] INDICATOR** - Turn on the Plasma generator by pressing the PLASMA ON/OFF button on the remote. PLASMAWAVE[®] generates both positive and negative ions to produce hydroxyl radicals that inactivate airborne contaminants.
7. **LIGHT SENSOR** - Automatically activates Sleep mode when room is darkened.
8. **FAN SPEED INDICATOR** - Shows current fan speed setting.
9. **SLEEP** - Sleep mode provides the lowest, quietest fan setting and a dimmed display panel.
10. **AUTO SLEEP MODE** - With the light sensor on, the unit will automatically operate in Sleep mode when the room is dark. When the room is light, the unit will revert to its previous settings.
11. **TIMER** - Indicates timer setting or continuous mode.
12. **POWER BUTTON** - Turn unit on and off by pressing the POWER button. Holding the button down for 2-3 seconds turns the Plasma generator on or off.

OPERATION

AUTOMATIC OPERATION

The unit is set to default to Automatic operation when it is first turned on. The air cleaner will automatically sense the amount of impurities in the air, and adjust the fan speed accordingly.



MANUAL OPERATION

After you turn on the unit, you can switch to manual operation by using the remote control or the FUNCTION button on the unit.

• LOW, MEDIUM, AND HIGH

These levels are recommended for standard daytime use. HIGH will activate automatically when sensors detect high levels of dust or odors.

For the first 4 minutes after turning the unit on, the sensors will flash while they measure current air quality.



LOW



MEDIUM



HIGH

• TURBO

The TURBO level, the highest fan speed, can be activated manually for maximum air circulation.



• PLASMA ON/OFF

Activate PLASMAWAVE[®] by depressing for 2-3 seconds the PLASMA ON/OFF button on the remote, or the POWER button on the unit. PLASMAWAVE[®] generates positive and negative ions.

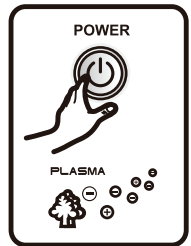

• TIMER

Set the timer for 1, 4, or 8 hours by pressing the TIMER button on the remote or the unit. The unit will stop operating when the set time is up. Cancel the timer by pressing the TIMER button until the 1-, 4-, and 8-hour indicator light on the unit disappears.



- **AUTO SLEEP**

Use the **TIMER** button on the display or remote to manually turn the light sensor on or off. With the light sensor on, the unit will automatically operate in Sleep mode when the room is dark. When the room is light, the unit will revert to its previous settings. Sleep mode provides the lowest, quietest fan setting and a dimmed display panel.



DUST AND ODOR SENSORS

The dust and odor sensors show elevated levels of air quality—green, orange, and red. The green light indicates acceptable dust and odor levels, the orange light indicates high levels, and the red light indicates very high levels. If the unit is set on Automatic operation, it will adjust fan speeds to compensate for increased or decreased levels of air pollution.

- **Odor Sensor**

The odor sensor responds to cigarette smoke and pet odors, as well as other air contaminants such as insecticides, cosmetics, alcohol, or aerosol sprays.

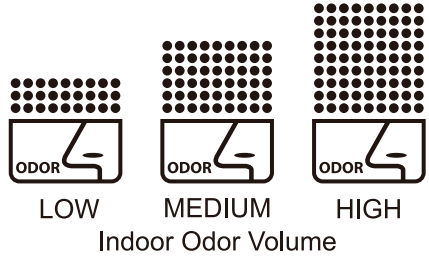

- **Dust Sensor**

The dust sensor detects particles in the air such as cigarette smoke, dust, and pollen.

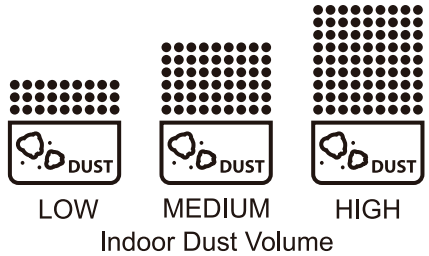

REMOTE CONTROL OPERATION

PREPARATION

- Press and slide the back cover of the remote to remove.
- Insert batteries as shown.
- Close the back cover.

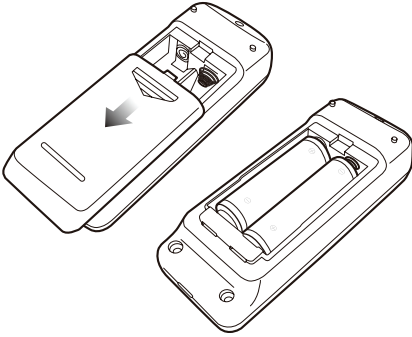

BATTERY USE

- The batteries for the remote control are for initial use only. Change the batteries when necessary.
- When replacing the batteries, replace both at once with 2 new AA batteries.
- Incorrect battery usage may cause battery fluid leakage and/or damage.
- When not using the remote control for an extended period of time, remove the batteries.
- Avoid dropping or damaging the remote control. Keep remote control away from direct sunlight or heaters.

USING THE REMOTE CONTROL

Proper conditions

- Operate the remote control facing the air cleaner.
- Operate within 600cms of the air cleaner.

Poor conditions that may impair operation

- Any location where there is inverter lighting equipment or electronic spontaneous lighting equipment.
- When objects or furniture are located between remote and air cleaner.
- When air cleaner unit is located in direct sunlight.
- In areas where fluorescent lighting is flickering due to worn out bulbs.

• POWER

Use the POWER button to turn the power on and off. A short "beep" will sound when you turn the unit on or off. Once the unit is on, it will automatically switch into Automatic operation. Turn the unit to manual control by pressing one of the FAN CONTROL buttons.

• TIMER

This button is used to set the timer. Press the button repeatedly to set the unit to run for 1, 4, or 8 hours, or to cancel. Each time you press the button, it will advance to the next pre-set amount of time. The indicator light on the unit will show the remaining amount of time. The unit will stop operating when the set amount of time runs out.

• FAN CONTROL

• UP

Use this button to switch from Automatic operation and increase the fan speed level.

• DOWN

Use this button to decrease the fan speed level.

• TURBO

Use this button to switch from Automatic operation and begin the maximum amount of room cleaning and air movement.

• AUTO SLEEP

Use the TIMER button to manually turn the light sensor on or off. With the light sensor on, the unit will automatically operate in Sleep mode when the room is dark. When the room is light, the unit will revert to its previous settings. Sleep mode provides the lowest, quietest fan setting and a dimmed display panel.

• PLASMA ON/OFF

Use this button to turn the PLASMAWAVE[®] generator on or off.

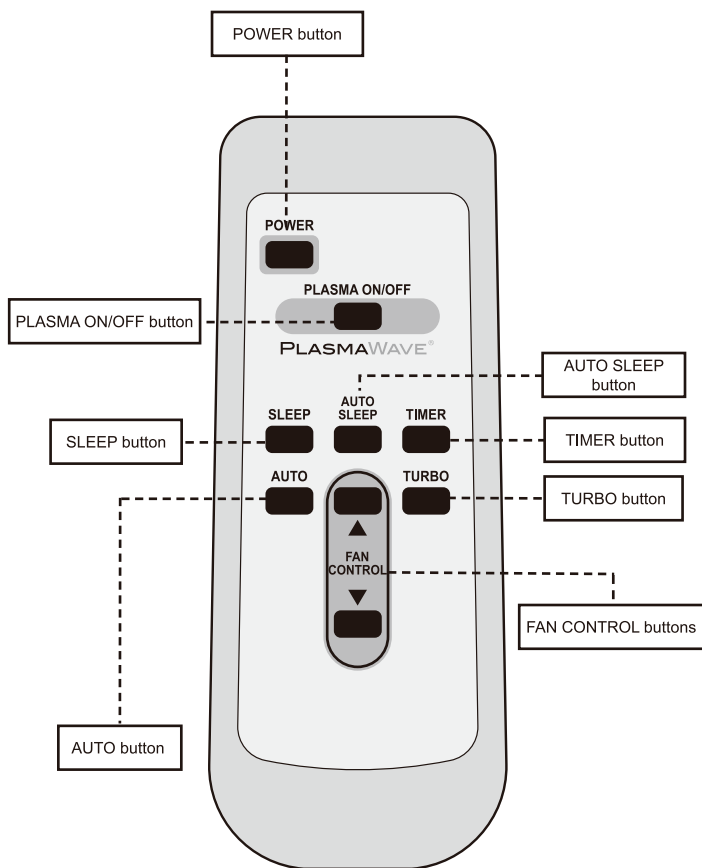

NOTE: This equipment generates, uses, and can radiate radio frequency energy and, if not installed and used in accordance with the instructions, may cause harmful interference to radio communications. However, there is no guarantee that interference will not occur in a particular installation. If this equipment does cause harmful interference to radio or television reception, which can be determined by turning the equipment off and on, the user is encouraged to try to correct the interference through one or more of the following measures:

- Reorient or relocate the receiving antenna.
- Increase the distance between the equipment and receiver.
- Connect the equipment to an outlet on a circuit different from that to which the receiver is connected.
- Consult an experienced radio/TV technician for help.

CARE AND MAINTENANCE

CLEANING

- Clean unit as necessary by wiping with a dry, soft cloth; for stubborn stains, use a warm, damp cloth.
- Do not use volatile fluids such as benzene, paint thinner, or scouring powder, as they may damage the unit surface.
- Keep the unit dry.
- Clean the wall behind the air outlet periodically, as it may become dirty.

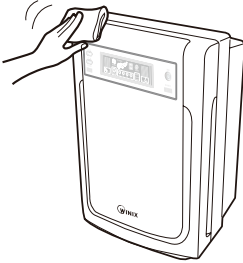

Filter Cassette Replacement

The CHANGE FILTER indicator will signal when to replace the filter cassette. The replacement period will vary depending on the hours of use, air quality, and location of the unit. However, most filters in normal use need to be replaced annually.

For your convenience, all three filters (Washable Anti-Bacterial Pre-Filter, True HEPA Filter, and Mesh/Carbon Filter) come in one pre-packaged replacement cassette.

For optimum unit efficiency, wash the Washable Anti-Bacterial Pre-Filter as described in Filter Cleaning every three months.

Do not wash and reuse the True HEPA Filter—it will not work effectively.

WARNING: Before replacing or cleaning any filters, make sure to remove the power plug from the wall outlet.

Replacement Procedure

1. Remove the front panel by grasping the bottom outside edges and gently pulling toward you.

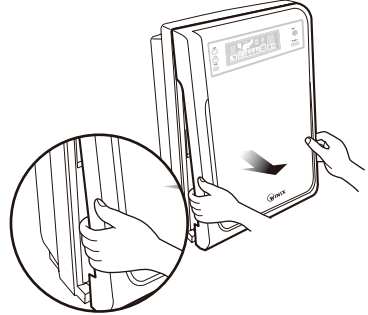

2. Pull out the filter cassette by grasping the tabs located on each side.

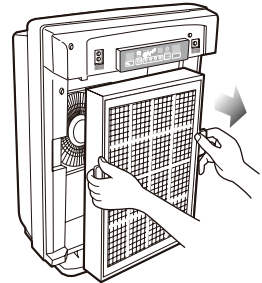

3. Remove the plastic wrap from the new filter cassette.

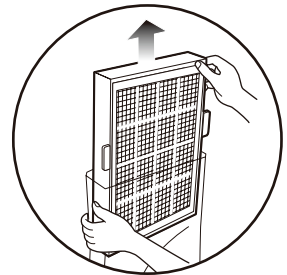

- Place the new filter cassette in the main unit, and press CHANGE FILTER reset button.

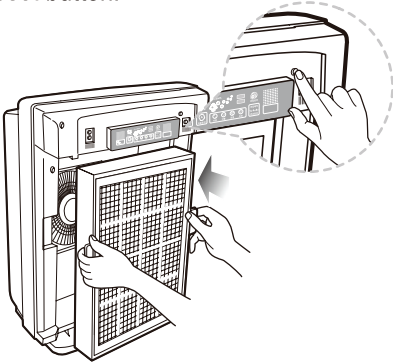

- Replace the front panel.

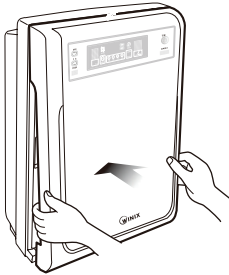

- Plug in the power cord to a wall outlet and turn on the unit.

Filter Cleaning

We recommend cleaning the Washable Anti-Bacterial Pre-Filter every three months with normal use. The interval between cleanings will vary based on room conditions.

- Remove the front panel and filter cassette as described in Replacement Procedure.

- Remove the Pre-Filter by gently pulling one side of the cassette frame outward while lifting the Pre-Filter tab at the same time. When one edge is clear of the frame, the Pre-Filter will slide out for cleaning.

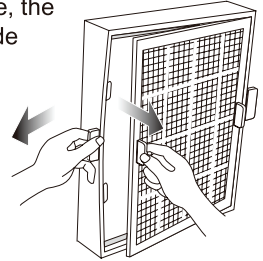

- Lightly vacuum the Pre-Filter and wash with water and a mild household detergent. Rinse, and shake off excess water.

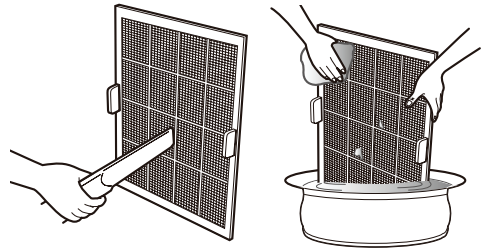

- To remove the Mesh /Carbon Filter, turn the cassette over and place face-down on an even surface. Slightly flex the cassette frame outward while pulling up on the long tab. When the first corner is released, pull out on the other long frame tab while continuing to pull out on the filter tab. When one long edge of the filter is free, slide out for cleaning.

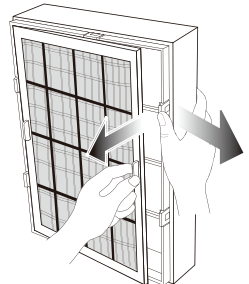

- Replace each filter in the cassette frame by inserting one long edge first, then snapping into place by pushing sideways and down at the same time. Make sure both filters are completely inside the cassette frame and secured by the short tabs. If a filter is on top of one or more tabs, pull outward, slightly flexing the cassette frame, while gently pushing down on the edge of the filter.
- Replace the filter cassette and front panel as described in Replacement Procedure.
- Plug in the power cord to a wall outlet and turn on the unit.

FILTER CASSETTE

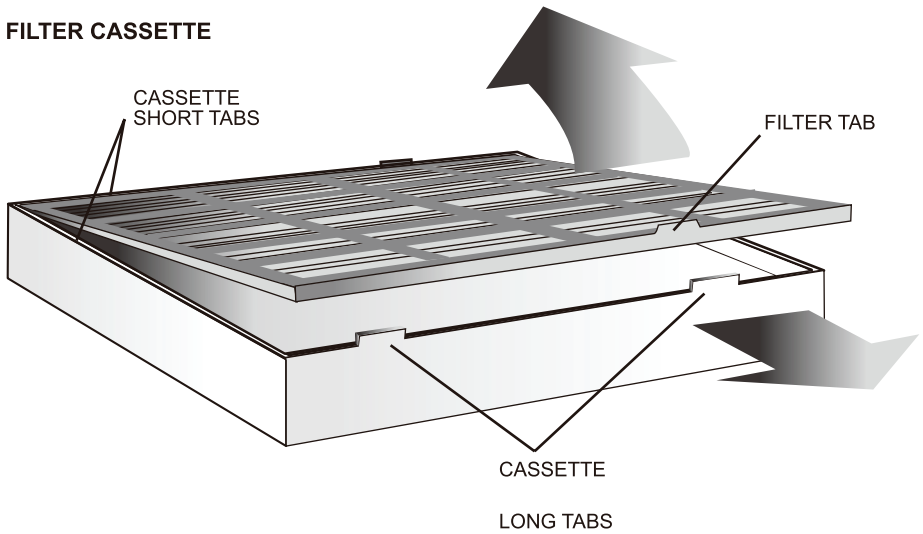

NOTE: Never attempt to remove the True HEPA Filter from the cassette frame. Never attempt to clean the True HEPA Filter. Replace the entire cassette when CHANGE FILTER alert activates.

Dust Sensor Cleaning

Lightly vacuum the dust sensor every two months after removing the front panel.

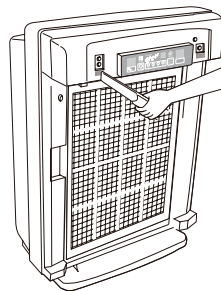

TROUBLESHOOTING

Before you call

Solutions to Common Problems

Review this list before you call for service. This list covers problems that are not the result of defective materials or workmanship.

PROBLEM	POSSIBLE SOLUTION
The remote control does not work.	<ul style="list-style-type: none"> • Make sure the remote control batteries are inserted correctly. • Replace worn-out batteries.
The unit leaves smoke and odors in the air.	<ul style="list-style-type: none"> • Make sure the sensor is not blocked or clogged. • Move the unit closer to the offending odors. • Replace or wash the filter as needed.
The unit seems to produce odors.	<ul style="list-style-type: none"> • Replace or wash the filter as needed.
The dust or odor light is green, but there is still dust/odor in the air.	<ul style="list-style-type: none"> • Clear the sensor with a vacuum cleaner, as it may be blocked or clogged.
The dust or odor light is orange or red, but the air seems clean.	<ul style="list-style-type: none"> • Clear the sensor with a vacuum cleaner, as it may be blocked or clogged.
Unit makes a ticking sound.	<ul style="list-style-type: none"> • This indicates that the PLASMAWAVE[®] function is working. If the sound is distracting, turn off this function while you are in the room.
Unit interferes with radio or television reception.	<ul style="list-style-type: none"> • Because this unit radiates radio frequency energy, we suggest you try one or more of the following: <ul style="list-style-type: none"> - For better reception, adjust the television/radio antenna. - Move the unit away from the affected television/radio. - Plug the unit power cord into an outlet different from the television/radio power cord.
The REPLACE FILTER indicator remains lit after replacing the filter cassette.	<ul style="list-style-type: none"> • With the power on, press the FILTER REPLACEMENT RESET button and hold for 5-10 seconds or until the light turns off.



This marking shown on the product or its literature, indicates that it should not be disposed with other household wastes at the end of its working life. To prevent possible harm to the environment or human health from uncontrolled waste disposal, please separate this from other types of wastes and recycle it responsibly to promote the sustainable reuse of material resources.

Household users should contact either the retailer where they purchased this product, or their local government office, for details of where and how they can take this item for environmentally safe recycling.

Business users should contact their supplier and check the terms and conditions of the purchase contract. This product should not be mixed with other commercial wastes for disposal.

WINIX Korea 35-1, Unjung-Dong, Bundang-gu , Seongnam-si, 463-440, South Korea
www.winixcorp.com Tel +82.31.701.1173(4544)