

Breville®

the Fast Slow Pro™

Instruction Booklet



BPR700

CONTENTS

- 3** Breville recommends safety first
- 8** Know your Breville product
- 10** Operating your Breville product
- 24** Care & cleaning
- 26** Troubleshooting
- 27** Recipes

At Breville we are very safety conscious. We design and manufacture consumer products with the safety of you, our valued customer, foremost in mind. In addition we ask that you exercise a degree of care when using any electrical appliance and adhere to the following precautions.

IMPORTANT SAFEGUARDS

READ ALL INSTRUCTIONS BEFORE USE AND SAVE FOR FUTURE REFERENCE

- Remove and safely discard any packaging material and promotional labels before use.
- To eliminate a choking hazard for young children, remove and safely discard the protective cover fitted to the power plug of this appliance.
- Always ensure the appliance is properly assembled before use. Follow the instructions provided in this book.
- Always insert the connector end of the power cord into the appliance inlet before inserting power plug into the power outlet and switching on appliance. Ensure the appliance inlet is completely dry before inserting the connector end of the power cord.
- Take care to avoid spillage on the connector.
- Do not touch hot surfaces. Appliance surfaces are hot during and after operation. To prevent burns or personal injury, always use protective hot pads or insulated oven mitts, or use handles or knobs where available.
- Do not place the appliance near the edge of a bench or table during operation. Ensure that the surface is dry, level, clean and free of any liquid and other substances.
- Always operate the appliance on a stable and heat resistant surface. Do not use on a cloth-covered surface, and position the appliance at a minimum distance of 20cm away from walls, curtains, cloths and other heat sensitive materials.

- Do not place this appliance on or near a hot gas or electric burner, or where it could touch a heated oven.
- Do not operate the appliance on a sink drain board.
- We recommend not to place the cooker on a stone bench top when it's cooking. This is due to bench tops being sensitive to uneven heat and may crack if heated locally. If you would like to cook with the slow cooker on the bench top, place a chopping board or heat proof mat underneath the cooker.
- Do not place anything, other than lid, on top of the cooker when assembled, when in use and when stored.
- Extreme caution must be used when the cooker contains hot food and liquids and/or is under pressure. Improper use may result in injury. When using this appliance for pressure cook, slow cook and steam, ensure the lid is properly assembled and locked into position before use.
- Do not move the cooker when in use.
- Do not use the lid handle to carry the appliance.
- Before placing removable cooking bowl into stainless steel base ensure the base of bowl and the base of the appliance is dry by wiping with a dry soft cloth.
- Do not use a damaged removable cooking bowl. Replace before using.
- Do not place food or liquid directly into the stainless steel base. Only the removable cooking bowl is designed to contain food or liquid.
- Never operate the cooker without food and liquid in the removable cooking bowl. Ensure the removable cooking bowl is filled to the level 2 mark or $\frac{1}{3}$ full of food and/or liquid.
- Always ensure there is enough liquid in the removable cooking bowl when steaming. At least 4 cups (1 litre) of liquid is required when steaming.

- Do not exceed maximum fill level. Some foods expand during pressure cooking such as rice, diced vegetables. Over filling may cause a risk of clogging pressure release valve and safety locking pin and develop excess pressure. Always follow the maximum and minimum quantities of liquid stated in instructions and recipes.
- Some foods to avoid when pressure cooking are; apple sauce, cranberries, pearl barley, oatmeal and other cereals, noodles and pasta, and rhubarb; these foods can foam, froth and splatter and clog the pressure release valve and safety locking pin.
- Before use, always check pressure release valve and safety locking pin for clogging and clean if necessary. Check to make sure the safety locking pin moves freely from under the lid.
- Do not attempt to open the cooker lid after pressure cooking until all internal pressure has been released and is slightly cooled. If the lid will not turn to unlock, this indicates that appliance is still under pressure – do not force lid open. Any pressure remaining can be hazardous. See operating instructions for STEAM RELEASE directions in this instruction book.
- Do not touch the pressure release valve whilst in use.
- Use only recommended STEAM RELEASE to depressurise cooker after use.
- Do not use this appliance for deep frying.
- Do not sauté or shallow fry under pressure.
- Do not use harsh abrasives, caustic cleaners or oven cleaners when cleaning this appliance. Keep the appliance clean and refer to care and cleaning section.
- Do not attempt to operate the appliance by any method other than those described in this booklet. Do not leave the appliance unattended when in use.

IMPORTANT SAFEGUARDS FOR ALL ELECTRICAL APPLIANCES

- Unwind the power cord fully before use.
- Do not let the power cord hang over the edge of a bench or table, touch hot surfaces or become knotted.
- Connect only to a 230V or 240V power outlet.
- To protect against electric shock, do not immerse the power cord, power plug or appliance in water or any other liquid.
- Always turn the appliance to the OFF position, switch off at the power outlet, remove the plug and allow all parts to cool before attempting to move the appliance, when the appliance is not in use, before cleaning and when storing.
- The appliance can be used by children aged from 8 years and above and persons with reduced physical, sensory or mental capabilities, or lack of experience and knowledge, if they have been given supervision or instruction concerning use of the appliance in a safe way and understand the hazards involved.
- Children shall not play with the appliance.
- Cleaning and user maintenance shall not be made by children unless they are older than 8 and supervised.
- Keep the appliance and its cord out of reach of children less than 8 years.

- It is recommended to regularly inspect the appliance. Do not use the appliance if the power cord, power plug or appliance becomes damaged in any way. Return the entire appliance to the nearest authorised Breville Service Centre for examination and/or repair.
- Any maintenance, other than cleaning, should be performed at an authorised Breville Service Centre.
- The use of attachments not sold or recommended by Breville may cause fire, electric shock or injury.
- This appliance is for household use only. Do not use this appliance for other than its intended use. Do not use in moving vehicles or boats. Do not use outdoors. Misuse may cause injury.
- The appliance is not intended to be operated by means of an external timer or separate remote control system.
- The installation of a residual current device (safety switch) is recommended to provide additional safety protection when using electrical appliances. It is advisable that a safety switch with a rated residual operating current not exceeding 30mA be installed in the electrical circuit supplying the appliance. See your electrician for professional advice.

**FOR HOUSEHOLD USE ONLY
SAVE THESE INSTRUCTIONS**

KNOW YOUR BREVILLE PRODUCT

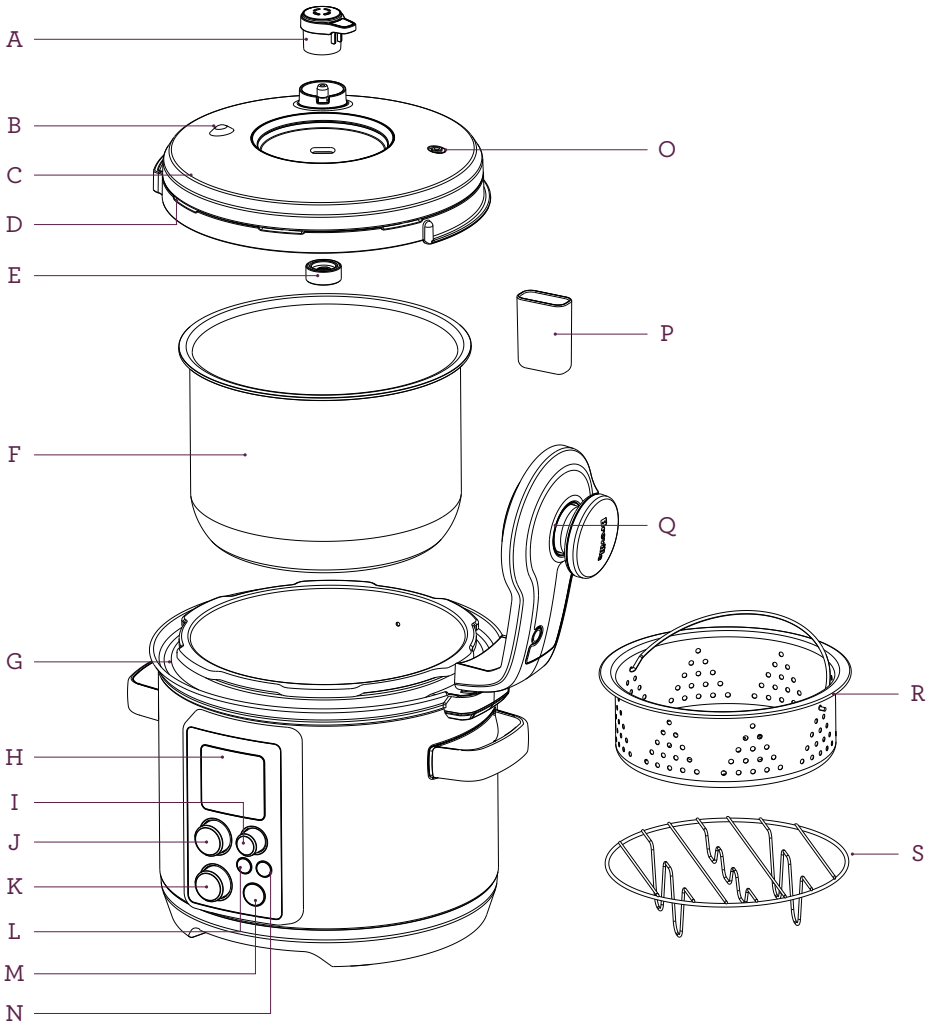

KNOW YOUR BREVILLE PRODUCT

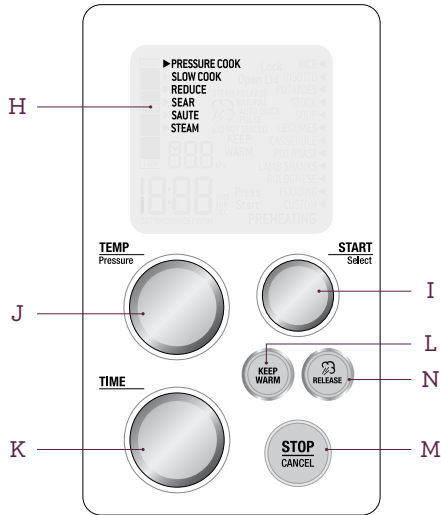

- A. Pressure Release Valve**
Automatically controls the rate at which steam is released from the cooker.
- B. Pressure Safety Valve**
- C. Dishwasher Safe Removable Lid**
- D. Silicone Lid Seal**
Easy fitting for hassle free assembly and cleaning.
- E. Sealing Nut**
- F. 6L Removable Cooking Bowl**
PTFE and PFOA free ceramic coating.
- G. Easy Clean Moat**
Catches condensation drips for a mess-free clean up.
- H. Interactive LCD**
Tells you when it's building pressure, cooking and releasing steam.
- I. Start/Select Dial**
- J. Temperature/ Pressure Dial**
8 pressure levels range from low for delicate foods to high for extra fast cooking.
2 heat settings allow slow cooking from 2 to 12 hours.
Select from 3 heat settings in sauté and reduce settings.
- K. Time Dial**
- L. Keep Warm**
- M. Stop/Cancel**
Press to pause or return to previous screen.
Press and hold to return to standby.
- N. Steam Release**
Press to select between Auto Quick, Auto Pulse and Natural Steam Release in set up and steam release mode.
Press and hold to open the pressure release valve.
- O. Safety Locking Pin**
Pin pops up once pressure is reached acting as a safety locking device.
- P. Condensation Drip Cup**
- Q. Lid Arm**
- R. Stainless Steamer**
- S. Stainless Trivet**
Raises food out of liquid for roasting, steaming.

PREPARING THE FAST SLOW PRO™

1. Remove and safely discard any packaging material, promotional labels and tape from the cooker.
2. Open the lid by turning the lid knob counter clockwise and lifting lid up and off the appliance until it is in the hinged open position. Unscrew and remove the sealing nut from the centre of the lid and pull the lid away to remove from the lid arm.
3. Wash the lid, removable cooking bowl and silicone lid seal in hot, soapy water, rinse and dry thoroughly. Wipe the inside and outside of the base with a soft, damp cloth and dry thoroughly.
4. Attach the clean silicone lid seal securely around the wire ring on the underside of the lid. Adjust position if necessary so that it sits comfortably and is free from any distortions.

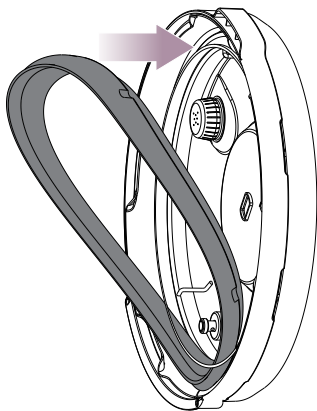

5. To reattach the lid, orient the lid so that the steam release valve housing is to the rear of the unit, and then align the centre of the lid with the bolt on the underside of the lid arm and push into position to expose the screw thread. Secure the lid by screwing on the sealing nut so that the red seal touches the lid surface.

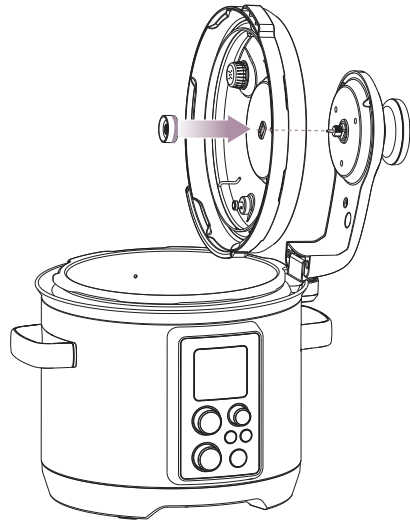

6. Clean and dry the bottom of the removable cooking bowl and the temperature sensor, making sure there are no unwanted materials on the surface. The removable cooking bowl must sit flat on the temperature sensor to ensure proper contact.

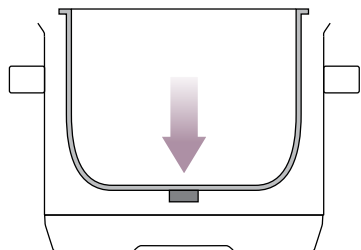

7. Click condensation drip cup into place.

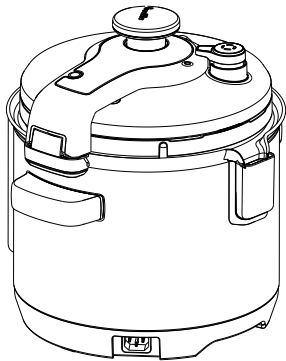
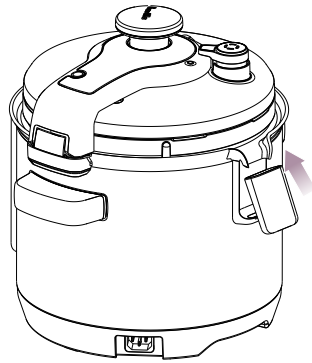

8. Insert the connector end of the power cord into the cooker base, ensuring it is completely dry. Insert the power plug in to a 230/240 volt (grounded) power outlet.
9. The cooker alert will sound and the LCD will illuminate. The setting options will appear with an indicator on the PRESSURE COOK setting.

SMART SETTINGS

The Fast Slow Pro™ features 6 Smart Settings; Pressure Cook, Slow Cook, Reduce, Sear, Sauté and Steam. Pressure and slow cook settings have a list of commonly used food types with pre-determined cook times and temperatures/pressure levels to give the best results, however we suggest experimenting with these depending on the recipe, amount of food and your personal taste. Alternatively, you can select the CUSTOM setting to select your own cooking times and temperatures/pressure levels.

Your CUSTOM setting will remain in the memory of the cooker. To reset to factory settings, switch off at the power outlet and press and hold START/SELECT while switching back on at the power outlet.

HANDS- FREE VARIABLE STEAM RELEASE

The Fast Slow Pro™ features 3 steam release methods:

Auto Quick

Pressure is released quickly to minimise overcooking of foods or recipes with short cook times.

Auto Pulse

Pressure is released in bursts to reduce disturbance to the food inside.

Natural

Pressure naturally subsides inside without releasing steam through the vent to prevent the churning up or breaking apart of sensitive ingredients like stocks and beans during pressure release.

These can be selected using the STEAM RELEASE button on the control panel during the set up and steam release cycles. Once selected, the pressure release valve will automatically release the steam at the end of the pressure cooking cycle.



Pressing and holding the steam release button during or after a cooking cycle will open the pressure release valve.

CAUTION

Always keep hands and face clear of the pressure release valve when pressure cooking as hot steam and water may be emitted during operation.

KEEP WARM

The KEEP WARM function maintains hot foods at safe serving temperature (60°C or above) until you are ready to serve for up to 2 hours.

To use KEEP WARM as a standalone function, press and hold the keep warm button on the control panel. The LCD screen will display 'KEEP WARM' and the timer will start counting up to a maximum of 2 hours. Turn the time dial to adjust the KEEP WARM time.



The KEEP WARM function will automatically switch on after any SLOW COOK cycle; however it can be toggled on and off in both PRESSURE COOK and SLOW COOK using the KEEP WARM button on the control panel.

ALTITUDE ADJUST

Pressure builds and increases when the temperature inside the cooking vessel exceeds boiling point. As altitude increases, the temperature at which water boils decreases as a result of the drop in air pressure. This creates very different conditions for cooking when using a pressure cooker.

In order to maintain consistent cooking results at various altitudes, the Fast Slow Pro™ has an Altitude Adjust feature that adjusts the settings based on the altitude of your current location.

1. To enter Altitude Adjust mode, press and hold STOP/CANCEL to activate standby mode. The button backlight will go out and the LCD will no longer illuminate.
2. Once in standby, press and hold both the KEEP WARM and STEAM RELEASE buttons for 2 seconds.
3. Turn the TIME dial to enter the altitude of your current location. Altitude can be adjusted from 250m to 1,999m. The pressure cooker should not be used at altitudes above 2,000m.

NOTE

Exact altitude can be found at www.elevationmap.net or by calling Breville Customer Service Centre.

4. Press the START/ SELECT dial to confirm.
5. The cooker's settings have now been adjusted for your current altitude. To reset altitude to sea level (factory settings), switch off at the power outlet and press and hold START/SELECT while switching back on at the power outlet.

COOKER SETTINGS OVERVIEW

SETTING	MENU	PRESETS	SUITABLE FOR	RANGE
PRESSURE COOK	RICE	50 kPa 10 MINS AUTO PULSE	Brown Rice White Rice Quinoa & Ancient Grains	10 kPa – 80 kPa Up to 2:00 HRS
	RISOTTO	40 kPa 7 MINS AUTO QUICK	Aborio Rice Carnaroli Rice Vialone Rice	10 kPa – 80 kPa Up to 2:00 HRS
	POTATOES	60 kPa 10 MINS AUTO PULSE	Whole & Cut Peeled & Unpeeled	10 kPa – 80 kPa Up to 2:00 HRS
	STOCK	80 kPa 1:00 HR NATURAL	Beef Stock Chicken Stock Vegetable Stock	10 kPa – 80 kPa Up to 2:00 HRS
	SOUP	50 kPa 30 MINS AUTO QUICK	Vegetable Soup Meat Soup	10 kPa – 80 kPa Up to 2:00 HRS
	LEGUMES	80 kPa 30 MINS NATURAL	Chickpeas Cannelini Beans Red Kidney Beans Green & Brown Lentils	10 kPa – 80 kPa Up to 2:00 HRS
	CASSEROLE	80 kPa 1:00 HR AUTO QUICK	All stewing meat such as Gravy Beef, Chuck & Skirt Steak Chicken pieces on the bone Whole Pork Shoulder (pulled pork)	10 kPa – 80 kPa Up to 2:00 HRS
	POT ROAST	60 kPa 30 MINS NATURAL	Whole Chicken Corned Beef Brisket Round/ Blade Roast Boneless Leg of Lamb	10 kPa – 80 kPa Up to 2:00 HRS
	LAMB SHANKS	80 kPa 30 MINS AUTO QUICK	Lamb Shanks Osso Bucco Ribs	10 kPa – 80 kPa Up to 2:00 HRS
	BOLOGNESE	70 kPa 20 MINS AUTO QUICK	Pork Mince Veal Mince Beef Chili	10 kPa – 80 kPa Up to 2:00 HRS
	PUDDING	50 kPa 15 MINS NATURAL	Custards Cheesecakes Puddings Compotes	10 kPa – 80 kPa Up to 2:00 HRS
CUSTOM	10 kPa 10 MINS AUTO PULSE		10 kPa – 80 kPa Up to 2:00 HRS	

OPERATING YOUR BREVILLE PRODUCT

SETTING	MENU	PRESETS	SUITABLE FOR	RANGE
SLOW COOK	STOCK	HI 4:00 HRS	Beef Stock Chicken Stock Vegetable Stock	HI, 2:00 – 12:00 HRS LO, 2:00 – 12:00 HRS KEEP WARM up to 2:00 HRS
	SOUP	HI 4:00 HRS KEEP WARM	Vegetable Soup Meat Soup	HI, 2:00 – 12:00 HRS LO, 2:00 – 12:00 HRS KEEP WARM up to 2:00 HRS
	LEGUMES	HI 6:00 HRS	Chickpeas Cannelini Beans Red Kidney Beans Green & Brown Lentils	HI, 2:00 – 12:00 HRS LO, 2:00 – 12:00 HRS KEEP WARM up to 2:00 HRS
	CASSEROLE	HI 4:00 HRS KEEP WARM	All Stewing meat such as Gravy Beef, Chuck & Skirt Steak Chicken pieces on the bone Whole Pork Shoulder (pulled pork)	HI, 2:00 – 12:00 HRS LO, 2:00 – 12:00 HRS KEEP WARM up to 2:00 HRS
	POT ROAST	LO 6:00 HRS KEEP WARM	Whole Chicken Corned Beef Brisket Round/ Blade Roast Boneless Leg of Lamb	HI, 2:00 – 12:00 HRS LO, 2:00 – 12:00 HRS KEEP WARM up to 2:00 HRS
	LAMB SHANKS	LO 8:00 HRS KEEP WARM	Lamb Shanks Osso Bucco Ribs	HI, 2:00 – 12:00 HRS LO, 2:00 – 12:00 HRS KEEP WARM up to 2:00 HRS
	BOLOGNESE	LO 6:00 HRS KEEP WARM	Pork Mince Veal Mince Beef Chili	HI, 2:00 – 12:00 HRS LO, 2:00 – 12:00 HRS KEEP WARM up to 2:00 HRS
	PUDDING	LO 2:00 HRS KEEP WARM	Custards Cheesecakes Puddings Compotes	HI, 2:00 – 12:00 HRS LO, 2:00 – 12:00 HRS KEEP WARM up to 2:00 HRS
	CUSTOM	HI 4:00 HRS KEEP WARM		HI, 2:00 – 12:00 HRS LO, 2:00 – 12:00 HRS KEEP WARM up to 2:00 HRS
REDUCE		HI 10 MINS	Finishing Sauces Thickening Cooking Sauce Reducing Syrups & Stocks	Up to 2:00 HRS
SEAR		COUNT UP TIME	Browning Meat Browning Hard Vegetables	Up to 45 MINS
SAUTE		HI COUNT UP TIME	Onion Garlic Curry Pastes Aromatics	Up to 45 MINS
STEAM		HI 15 MINS	Vegetables Fish & Chicken Fillets Seafood e.g. Prawns & Mussels Dumplings & Wontons	Up to 1:00 HR

PRESSURE COOK

The PRESSURE COOK setting is a great option for cooking succulent roasts, flavoursome casseroles, delicious soups and even desserts in a fraction of the time and energy they take by conventional methods.

Pressure Cooking is a method of cooking food in a small amount of liquid with a gasket sealed lid that retains steam inside and builds pressure. It is the increase in pressure that raises temperature of the liquid and steam inside to well above boiling point and therefore allows food to be cooked up to 70% faster.

1. Turn the START/SELECT dial until the indicator reaches the PRESSURE COOK setting. Press the START/SELECT dial to confirm.
2. Turn the START/SELECT dial until the indicator on the right hand side of the LCD reaches the desired setting.

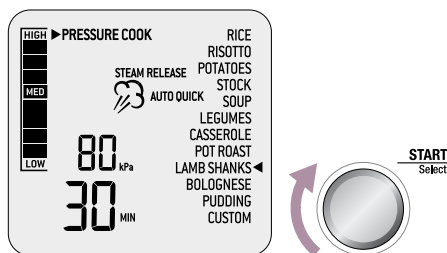

3. The top figure on the LCD screen indicates the preset pressure level for the selected setting. Turn the TEMPERATURE/PRESSURE dial to the left to reduce the pressure or to the right to increase pressure. Pressure can be adjusted from 10 kPa (LOW) to 80 kPa (HIGH).
4. The bottom figure on the LCD screen indicates the preset cooking time for the selected setting. Turn the TIME dial to the left to reduce the cooking time or to the right to increase the cooking time. Time can be adjusted up to 2 hours.

5. The steam icon on the LCD screen indicates the preset steam release method for the selected setting. Press the STEAM RELEASE button to select between 'AUTO QUICK', 'AUTO PULSE' and 'NATURAL' steam release.
6. Place food into the removable cooking bowl. Ensure there is at least 1L of combined food and liquid in the bowl.



7. Close the lid and turn the lid knob clockwise to lock into place. The cooker alert will sound when the lid has been locked.
8. Ensure the pressure release valve is placed on the lid in the closed position.

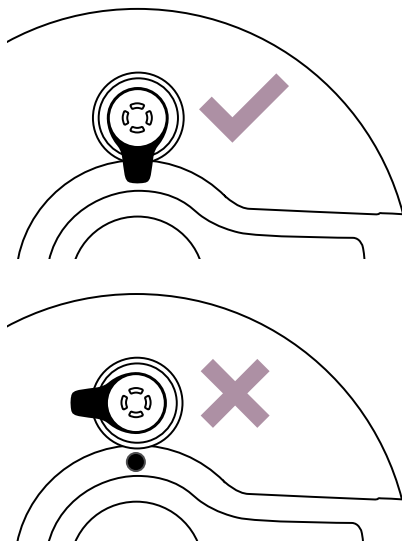

OPERATING YOUR BREVILLE PRODUCT

9. Press the START/SELECT dial to commence cooking. The STOP/CANCEL button backlight will illuminate red, the LCD screen will illuminate orange, 'PREHEATING' will appear and the pressure bar on the left will climb to indicate the cooker is building pressure.

NOTE

It is normal for the cooker to release small bursts of steam as it stabilises.

10. If the lid has not been locked correctly 'LOCK LID' will appear on the LCD screen. Turn the lid knob clockwise to lock the lid and commence cooking.
11. Once the cooker has reached pressure, the 'PREHEATING' will go out, the cooker alert will sound, the timer will start counting down and the pressure bar will stop climbing, indicating the current pressure in the vessel.
12. The time can be adjusted during the pressure cook cycle by turning the TIME dial. The cycle can be paused at any time by pressing the STOP/CANCEL button. To end the cycle press and hold STOP/CANCEL for 2 seconds. If there is already pressure in the vessel it will go immediately to the steam release cycle.
13. At the end of the pressure cook cycle, the cooker alert will sound and steam will be automatically released through the pressure release valve. The steam icon will blink, the timer will start counting up and the pressure bar will decrease, indicating the current pressure in the vessel.

If NATURAL steam release is selected, pressure will naturally subside in the vessel without forcing steam through the pressure release valve. The steam release setting can be changed during the steam release cycle by pressing the STEAM RELEASE button.
14. At the end of the steam release cycle, the cooker alert will sound, the LCD will illuminate blue and the timer will start counting up.
15. Open the lid by turning the lid knob counter clockwise and carefully lift the lid into the hinged open position.
16. After 5 minutes of inactivity, standby mode will be activated. The button backlight will go out and the LCD will no longer illuminate.



CAUTION

To avoid scalding from escaping steam, never place your face or hands over the cooker when removing the lid.

NOTE

If the lid will not unlock this indicates the appliance is still under pressure. Do not force the lid open as any remaining pressure can be hazardous. Press the STEAM RELEASE button until all internal pressure is released and the cooker can be opened.

SLOW COOK

The SLOW COOK setting has cooking profiles designed for long cook times at low temperatures. It is ideal for breaking down tough cuts of meat and developing deep flavours.

1. Turn the START/SELECT dial until the indicator reaches the SLOW COOK setting. Press the START/SELECT dial to confirm.
2. Turn the START/SELECT dial until the indicator on the right hand side of the LCD reaches the desired setting.

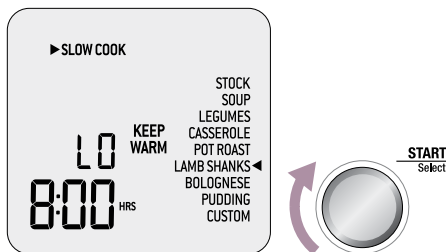

3. The top figure on the LCD screen indicates the preset temperature for the selected setting. Turn the TEMPERATURE/PRESSURE dial to the left to reduce the temperature or to the right to increase temperature. Temperature can be adjusted to one of two preset temperatures; 'LO' or 'HI'.
4. The bottom figure on the LCD screen indicates the preset cooking time for the selected setting. Turn the TIME dial to the left to reduce the cooking time or to the right to increase the cooking time. Time can be adjusted between 2 and 12 hours.
5. 'KEEP WARM' indicates the KEEP WARM function will automatically switch on after the SLOW COOK cycle. Press the KEEP WARM button on the control panel to select or deselect the function.

6. Place food into the removable cooking bowl. Ensure there is at least 1L of combined food and liquid in the bowl.



7. Close the lid but do not lock.
8. Remove the pressure release valve from the lid.
9. Press the START/SELECT dial to commence cooking. The STOP/CANCEL button backlight will illuminate red and the LCD screen will illuminate orange.
10. The timer will be displayed and automatically begin to count down. The time can be adjusted during the slow cook cycle by turning the TIME dial. The cycle can be paused at any time by pressing the STOP/CANCEL button. To end the cycle press and hold STOP/CANCEL for 2 seconds.
11. At the end of the slow cook cycle, the cooker will automatically switch to the KEEP WARM function. The LCD screen will display 'KEEP WARM' and the timer will start counting up to a maximum of 2 hours. The keep warm cycle can be paused at any time by pressing the STOP/CANCEL button.
12. If KEEP WARM has not been selected, the cooker alert will sound, the STOP/CANCEL button backlight will go out and the LCD screen will illuminate blue.
13. After 5 minutes of inactivity, standby mode will be activated. The button backlight will go out and the LCD will no longer illuminate.

TIPS FOR PRESSURE & SLOW COOKING

Rice

- The PRESSURE COOK RICE setting is designed to cook rice so the rice grains remain separate and tender.
- The rice setting is suitable for all types of rice such as long grain rice, jasmine, basmati and brown rice.
- Weigh dry rice accurately and wash well with cold water until water runs clear. Drain well and place into the removable cooking bowl.
- Add corresponding water amount. Water to rice ratio is based on 1.5 parts water to 1 part rice. See Rice table on this page.
- After cooking, allow rice to stand in bowl for 5 minutes before stirring and serving.

RICE	WATER	SERVES
200g	300ml	1-2
250g	375ml	2
300g	450ml	2-3
350g	525ml	3-4
400g	600ml	4-5
450g	675ml	5-6
500g	750ml	6-7
600g	900ml	7-8

Risotto

- The PRESSURE COOK RISOTTO setting is ideal for making creamy and flavoursome risotto without all the stirring, and in less than half the time.
- With little or no evaporation during pressure cooking, it is important to keep to the ratio of 1 part rice to 3 parts stock.
- If adding a lot of vegetables to the risotto, reduce stock by a third.
- Use the SAUTÉ setting so soften the onions, vegetables and aromatics and to deglaze the pan with wine.
- The key to creamy risotto is toasting the rice grains before the liquid is added. For best results, use SAUTÉ setting to toast the grains prior to cooking. Stir rice grains for 2-3 minutes or until the edges of the rice grains become transparent and then turn white.
- Rice will swell and double in size after cooking. For best results, do not overfill the cooking bowl. The total volume of uncooked rice and stock should not exceed the level 8 marking inside the removable cooking bowl.

Potatoes

- The PRESSURE COOK POTATO setting is suitable for cooking both large and small portions of potato.
- This setting is ideal to cook both peeled and cut potatoes and whole large unpeeled potatoes.
- If pressure cooking large whole potatoes, wash well and prick potato 3-4 times with a fork.
- Add 1 cup of water to the cooking bowl along with prepared potatoes.
- For best results, do not overfill the cooking bowl. The total volume of potatoes should not exceed the level 10 marking inside the removable cooking bowl.

Stock

- The **PRESSURE & SLOW COOK STOCK** setting is suitable for beef, chicken and vegetable stocks.
- If brown stocks are required, use **SEAR** setting to colour beef or chicken bones prior to pressure cooking.
- Vegetables such as onion, carrot and celery should be cut into large pieces. This will make it easier to strain at the end of cooking.
- To shorten the pressurising time, either add hot water to caramelised bones and aromatics, or add cold water to bones while still in **SEAR** setting and allow the water to come to a simmer before pressure cooking.
- For best results, do not overfill the cooking bowl. The total volume of water, bones and/or aromatics should not exceed the **MAX** level marking inside the removable cooking bowl.

Soup

- The **PRESSURE & SLOW COOK SOUP** setting is suitable to cook a variety of soups from light broths to hearty minestrone and pureed vegetable soups.
- Use **SAUTÉ** setting to begin caramelising aromatics and softening vegetables, or **SEAR** setting to brown meats, bacon or chicken.
- To shorten the pressurising time, either add hot water or stock to aromatics, or add cold water/stock to bowl while still in **SEAR** setting and allow the water to come to a simmer before pressure cooking.
- For best results, do not overfill the cooking bowl. The total volume of soup should not exceed the **MAX** level marking inside the removable cooking bowl.

Legumes

- The **PRESSURE & SLOW COOK LEGUME** setting is suitable for cooking all types of legumes and pulses such as chickpeas, red kidney beans and lentils.
- Legumes and beans can produce a lot of foam during cooking. The pre-set **NATURAL** steam release setting ensures foam does not interfere with the steam release valve .
- Cook times are based on dried legumes. To shorten the cook time, soak beans in cold water overnight. Discard soaking water and cook with fresh cold water for half the pre-set cooking time.
- Use water ratio of 1 part legumes to 3 parts water.
- Legumes and beans swell and double in size after cooking. For best results, do not overfill the cooking bowl. The total volume of uncooked legumes and water, should not exceed the level 8 marking inside the removable cooking bowl.

Casserole

- The **PRESSURE & SLOW COOK CASSEROLE** setting is ideal to cook a selection of meats, vegetables and chicken using either diced tough cuts or pieces on the bone.
- Unlike traditional stewing or braising, pressure and slow cooking have almost no evaporation. To develop thick and rich flavoured dishes, use only enough stock and liquids to just cover ingredients; approx. 1 - ½ cups in total.
- For best results, do not overfill the cooking bowl. The total volume of uncooked casserole ingredients should not exceed the level 10 marking inside the removable cooking bowl.

Pot Roast

- The PRESSURE & SLOW COOK POT ROAST setting is ideal for cooking tough cuts of meat such as chuck or blade roast, brisket and even whole chicken.
- Unlike traditional stewing or braising, pressure and slow cooking have almost no evaporation. To develop thick and rich flavoured dishes, use only enough stock and liquids to just cover ingredients; approx. 1 - ½ cups in total.
- Select size of meat that will fit easily into removable cooking bowl.
- For best results, use SEAR setting to brown meat prior to cooking.
- Do not overfill the cooking bowl. The total volume of uncooked ingredients should not exceed the level 10 marking inside the removable cooking bowl.

Lamb Shanks

- The PRESSURE & SLOW COOK LAMB SHANK setting uses the correct temperature/ pressure and time to soften meat fibres and dissolve connective tissue. This allows meat to become succulent and flaky, easily falling off the bone and ready to eat. Sauces become thick and well developed.
- Choose lamb shanks that will fit easily into the removable cooking bowl or ask your butcher to trim shanks.
- For best results, use SEAR setting to brown meat prior to cooking.
- Unlike traditional stewing or braising, pressure and slow cooking have almost no evaporation. To develop thick and rich flavoured dishes, use only enough stock and liquids to just cover ingredients; approx. 1 - ½ cups in total.
- Do not overfill the cooking bowl. The total volume of uncooked lamb shank ingredients should not exceed the level 12 marking inside the removable cooking bowl.

Bolognese

- The PRESSURE & SLOW COOK BOLOGNESE setting will cook this Italian classic to perfection.
- Choose from beef, pork or pork and veal mince.
- For best results, use SEAR & SAUTÉ settings to brown meat and soften aromatics prior to cooking.
- Do not overfill the cooking bowl. The total volume of uncooked ingredients should not exceed the level 10 marking inside the removable cooking bowl.

Pudding

- The PRESSURE & SLOW COOK PUDDING setting is ideal for cakes, cheesecakes, custards, puddings, and fruit compotes.
- Large single cakes and small ramekins can be used. The smaller the size of the dessert or pudding the shorter the cook time and vice-versa.
- Suitable cookware materials include aluminium, stainless, silicone, Pyrex and ceramic. Each material will cook differently. Be aware of cookware differences when adjusting cook times.
- Cook cakes and puddings uncovered with the exception of custards.
- Arrange ramekins on a trivet inside the removable cooking bowl.
- Do not overfill the cooking bowl. The total volume of uncooked ingredients should not exceed the MAX level marking inside the removable cooking bowl.
- For fruit and compotes, the total volume of uncooked fruit should not exceed the level 10 marking inside the removable cooking bowl.

REDUCE

The REDUCE setting is ideal for thickening and intensifying the flavour of sauces, syrups and stocks.

1. Turn the START/SELECT dial until the indicator reaches the REDUCE setting. Press the START/SELECT dial to confirm.
2. The top figure on the LCD screen indicates the preset temperature for the REDUCE setting. Turn the TEMPERATURE/PRESSURE dial to the left to reduce the temperature or to the right to increase temperature. Temperature can be adjusted to one of three preset temperatures; 'LO', 'MED' or 'HI'.
3. The bottom figure on the LCD screen indicates the preset cooking time for the REDUCE setting. Turn the TIME dial to the left to reduce the cooking time or to the right to increase the cooking time. Time can be adjusted up to 2 hours.
4. Place liquid to be reduced into the removable bowl.
5. Press the START/SELECT dial to commence cooking. The STOP/CANCEL button backlight will illuminate red, the LCD screen will illuminate orange and indicate 'PREHEATING'.
6. Keep the lid open in the hinged position. If the lid has not been opened the cooker alert will sound and 'OPEN LID' will appear on the LCD screen.
7. Once the cooker has reached temperature, 'PREHEATING' will go out. Place liquid to be reduced into the removable cooking bowl.
8. The timer will start counting down. The time can be adjusted during the reduce cycle by turning the TIME dial. The cycle can be paused at any time by pressing the STOP/CANCEL button. To end the cycle press and hold STOP/CANCEL for 2 seconds.
9. At the end of the reduce cycle, the cooker alert will sound, the STOP/CANCEL button backlight will go out and the LCD screen will illuminate blue.
10. After 5 minutes of inactivity, standby mode will be activated. The button backlight will go out and the LCD will no longer illuminate.

NOTE

If reducing cooking sauce from pressure and slow cooking, remove cooked meat or vegetables.

Once sauce has reached the correct consistency and flavour, return meat and allow to warm through for a few minutes before serving.

SEAR

The SEAR setting is designed to enhance and deepen the taste of meals by using the same cooking bowl for caramelising and browning foods before pressure or slow cooking.

1. Turn the START/SELECT dial until the indicator reaches the SEAR setting. Press the START/SELECT dial to confirm.
2. The STOP/CANCEL button backlight will illuminate red, the LCD screen will illuminate orange and indicate 'PREHEATING'.
3. Keep the lid open in the hinged position. If the lid has not been opened the cooker alert will sound and 'OPEN LID' will appear on the LCD screen.
4. Once the cooker has reached temperature, 'PREHEATING' will go out. Place food to be cooked into the removable cooking bowl.
5. The timer will start counting up to a maximum of 45 minutes. The cycle can be paused at any time by pressing the STOP/CANCEL button. To end the cycle press and hold STOP/CANCEL for 2 seconds.
6. At the end of the sear cycle, the cooker alert will sound, the STOP/CANCEL button backlight will go out and the LCD screen will illuminate blue.
7. After 5 minutes of inactivity, standby mode will be activated. The button backlight will go out and the LCD will no longer illuminate.

SAUTÉ

The SAUTÉ setting is ideal for softening and caramelising garlic, onions and smaller pieces of food prior to pressure or slow cooking.

1. Turn the START/SELECT dial until the indicator reaches the SAUTÉ setting. Press the START/SELECT dial to confirm.
2. The top figure on the LCD screen indicates the preset temperature for the SAUTÉ setting. Turn the TEMPERATURE/PRESSURE dial to the left to reduce the temperature or to the right to increase temperature. Temperature can be adjusted to one of three preset temperatures; 'LO', 'MED' or 'HI'.
3. Press the START/SELECT dial to commence cooking. The STOP/CANCEL button backlight will illuminate red, the LCD screen will illuminate orange and indicate 'PREHEATING'.
4. Keep the lid open in the hinged position. If the lid has not been opened the cooker alert will sound and 'OPEN LID' will appear on the LCD screen.
5. Once the cooker has reached temperature, 'PREHEATING' will go out. Place food to be cooked into the removable cooking bowl.
6. The timer will start counting up. The cycle can be paused at any time by pressing the STOP/CANCEL button. To end the cycle press and hold STOP/CANCEL for 2 seconds.
7. At the end of the sauté cycle, the cooker alert will sound, the STOP/CANCEL button backlight will go out and the LCD screen will illuminate blue.
8. After 5 minutes of inactivity, standby mode will be activated. The button backlight will go out and the LCD will no longer illuminate.

STEAM

The STEAM setting is ideal for steaming vegetables, fish fillets, dumplings and reheating dinner plates.

1. Turn the START/SELECT dial until the indicator reaches the STEAM setting. Press the START/SELECT dial to confirm.
2. The bottom figure on the LCD screen indicates the preset cooking time for the STEAM setting. Turn the TIME dial to the left to reduce the cooking time or to the right to increase the cooking time. Time can be adjusted up to 1 hour.
3. Fill the removable cooking bowl with water to the level 6 marking.
4. Insert the trivet into the bowl and place the steaming basket on top. If reheating dinner plates, place the plate on top of the trivet.
5. Arrange food on the steamer allowing 1cm gaps between the food so the steam can flow evenly around all sides.
6. Close the lid but do not lock.
7. Remove the pressure release valve from the lid.
8. Press the START/SELECT dial to commence cooking. The STOP/CANCEL button backlight will illuminate red, the LCD screen will illuminate orange and 'PREHEATING'.
9. Once the cooker has reached temperature, 'PREHEATING' will go out.
10. The timer will start counting up to a maximum of 45 minutes. The time can be adjusted during the steam cycle by turning the TIME dial. The cycle can be paused at any time by pressing the STOP/CANCEL button. To end the cycle press and hold STOP/CANCEL for 2 seconds.
11. At the end of the steam cycle, the cooker alert will sound, the STOP/CANCEL button backlight will go out and the LCD screen will illuminate blue.
12. If further steaming is required, check water levels and refill as required.
13. After 5 minutes of inactivity, standby mode will be activated. The button backlight will go out and the LCD will no longer illuminate.



CAUTION

To avoid scalding from escaping steam, never place your face or hands over the cooker when removing the lid.

Before cleaning, ensure the cooker is turned off by pressing and holding the STOP/CANCEL button on the control panel. The cooker is off when the button backlight is no longer illuminated.

Remove the power plug from the power outlet and remove the connector end of the power cord from the cooker base. Allow the cooker and all accessories to cool completely before disassembling and cleaning.

CLEANING THE BOWL AND OUTER BODY

1. The removable cooking bowl can be washed in the dishwasher. However, to maintain the ceramic coating, it is recommended to wash the cooking bowl in warm soapy water using a mild household detergent. Rinse with clean water and dry thoroughly.
2. Wipe the moat and outer body with a soft, damp sponge. A non-abrasive liquid cleanser or mild spray solution may be used to avoid build-up of stains. Apply the cleanser to the sponge, not the cooker surface, before cleaning.
3. Remove condensation drip cup by gently pulling the bottom away from the body. Wash in warm soapy water, rinse with clean water, dry thoroughly and click back into position.
4. Wipe the LCD screen with a soft damp cloth. Cleaning with dry cloth or abrasive cleaners may scratch the surface.
5. Let all surfaces dry thoroughly prior to inserting the power plug into a power outlet and turning the cooker on.

WARNING

Do not immerse the body, power cord or power plug in water or any other liquid as this may cause electrocution.

CLEANING THE LID

1. Remove the pressure release valve from the lid.
2. Open the lid by turning the lid knob counter clockwise and lifting lid up and off the appliance until it is in the hinged open position. Unscrew and remove the sealing nut from the centre of the lid and pull the lid away to remove from the lid arm.
3. Gently pull the silicone lid seal out from around the wire ring on the underside of the lid.
4. Wash the sealing nut and pressure release valve in warm soapy water. Rinse with clean water and dry thoroughly.
5. Wash the silicone lid seal and the lid on the top rack of the dishwasher. Alternatively, wash in warm soapy water, rinse with clean water and dry thoroughly.
6. After cleaning the lid, regularly inspect and ensure:
 - a) Safety locking pin moves up and down freely. Always remove any oil or food residue left on this area.

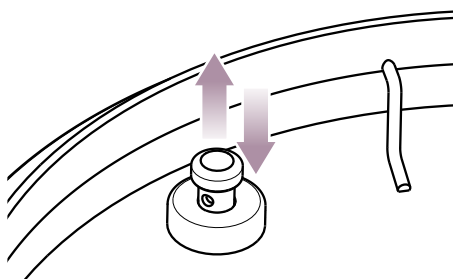

- b) Pressure release valve and cover are clean and free of food or liquid. To clean, twist and pull the pressure release valve cover off the lid, wipe with a soapy cloth, rinse and dry thoroughly. Clip cover back into its original position.

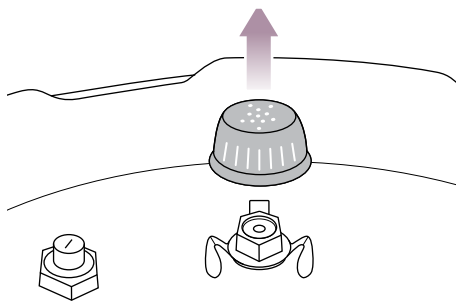

- c) Pressure safety valve is clean and free of food or liquid. To clean, push the valve from inside so the valve sits open on the lid and remove any oil or food residue. Ensure the valve moves in and out smoothly after cleaning.

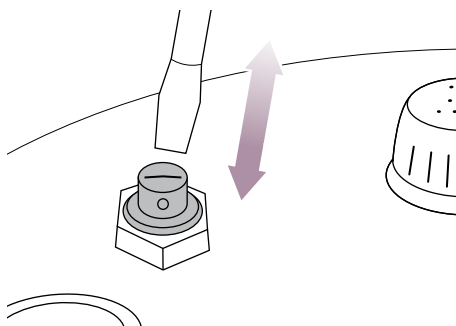

- Attach the clean silicone lid seal securely back around the wire ring on the underside of the lid. Adjust position if necessary so that it sits comfortably and is free from any distortions.
- To reattach the lid, orient the lid so that the steam release valve housing is to the rear of the unit, and then align the centre of the lid with the bolt on the underside of the lid arm and push into position to expose the screw thread. Secure the lid by screwing on the sealing nut so that the red seal touches the lid surface.

CLEANING THE STEAMING TRAY AND TRIVET

- Wash all accessories in warm soapy water with a soft sponge or soft plastic scouring pad. Rinse and dry thoroughly.
Do not use abrasive cleansers, metal scouring pads or metal utensils to clean any of the accessories as they may damage the surfaces.
- To extend the life of your accessories, we do not recommend that these be placed in the dishwasher.

TIP

Pressure cook 1 tablespoon vanilla, ½ cup lemon juice, 1 tablespoon lemon rind and 500ml hot water for 5 minutes to help eliminate food odours.

STORAGE

- Ensure the cooker is turned off by pressing the STOP/CANCEL button on the control panel. The cooker is off when the button backlight is no longer illuminated.
- Remove the power plug from the power outlet. Allow the cooker and all accessories to cool completely before disassembling and cleaning.
- Ensure the cooker and all accessories are clean and dry.
- Ensure the bowl is inserted into the cooker; the trivet is inserted into the steaming tray and placed inside the bowl.
- Ensure the lid is closed and in the locked position.
- Store the appliance in an upright position standing level on its support legs. Do not store anything on top.

TROUBLESHOOTING

PROBLEM	EASY SOLUTION
The lid cannot be opened at the end of the cooking cycle	<ul style="list-style-type: none"> • Press the STEAM RELEASE button until all internal pressure is released and the cooker can be opened. • If this occurs frequently, the cooker may need to be adjusted to suit your current altitude. Follow “Altitude Adjust” instructions on page 12. <p>NOTE: The safety locking pin will drop when the lid can be open.</p>
‘Open Lid’ is displayed on the LCD when the lid is open	<ul style="list-style-type: none"> • Turn the lid knob clockwise and counter clockwise.
Steam is escaping from the lid	<ul style="list-style-type: none"> • Assemble the lid correctly ensuring there is no gap between lid arm and the stainless steel lid. The sealing nut should be screwed up tightly. • Ensure the silicone lid seal is fitted correctly. Follow “Preparing the Fast Slow Pro” instructions on page 10. • Clean the silicone lid seal or inspect for any cracks or cuts and replace if required. Follow “Care and Cleaning” instructions on page 24. • Ensure that the safety locking pin can move freely up and down. • Ensure that the pressure release valve is in place and oriented correctly. Follow step 8 on page 15.
The Safety Locking Pin does not rise in the Pressure Cook setting (unable to build pressure)	<ul style="list-style-type: none"> • Ensure that the pressure release valve is in place and oriented correctly. Follow step 8 on page 15. • Add more liquid/food to the bowl. • Call Breville Customer Service.
The cooker automatically switches to keep warm without going through a complete cooking cycle	<ul style="list-style-type: none"> • Add more water to the cooking bowl and restart the cycle.
Water is collecting on the benchtop	<ul style="list-style-type: none"> • Ensure the unit is on a flat level surface and that the condensation drip cup is assembled on the back of the cooker. Follow “Preparing the Fast Slow Pro” instructions on page 10. • Empty the condensation drip cup. Follow “Care and Cleaning” instructions on page 24.

RECIPES

visit www.foodthinkers.com.au

Breville®

Breville Customer Service Centre

Australian Customers

Mail: PO Box 22
Botany NSW 2019
AUSTRALIA

Phone: 1300 139 798

Fax: (02) 9384 9601

Email: Customer Service:
askus@breville.com.au

New Zealand Customers

Mail: Private Bag 94411
Botany Manukau 2163
Auckland NEW ZEALAND

Phone: 0800 273 845

Fax: 0800 288 513

Email: Customer Service:
askus@breville.co.nz

Breville is a registered trademark of Breville Pty. Ltd. A.B.N. 98 000 092 928.
Copyright Breville Pty. Ltd. 2015.

Due to continued product improvement, the products illustrated/photographed
in this brochure may vary slightly from the actual product.

BPR700 ANZ A15