

Ⓒ GB INSTALLATION, USE AND MAINTENANCE INSTRUCTION

**SL-EM906 / SL906 1Mot. / SL906 2Mot. /SL907
SL-EM906-L / SL906-L 1 MOT / SL906-L 2 MOT**

TECHNICAL INFORMATION

TYPE: FSLC



GB



The symbol on the product or on its packaging indicates that this product may not be treated as household waste. Instead it shall be handed over to the applicable collection point for the recycling of electrical and electronic equipment. By ensuring this product is disposed of correctly, you will help prevent potential negative consequences for the environment and human health, which could otherwise be caused by inappropriate waste handling of this product. For more detailed information about recycling of this product, please contact your local city office, your household waste disposal service or the shop where you purchased the product. This appliance is marked according to the European directive 2002/96/EC on waste electrical and electronic equipment (WEEE).

CONTENTS

GB

Warnings

Uses

Installation

Working

Maintenance

WARNINGS

– The cooker surface and the inferior part of the cooker hood must be at a minimum distance of 65 cm. To ensure good performances of the product is recommended to install the hood centrally with respect to the cook top (Fig.18).

– The air sucked can't be conveyed through or into a duct used to let out fumes from appliances fed by energy other than electric power (eg. centralized heating, radiators, water-heaters, etc.).

– Attention: remove any possible pvc film from the stainless steel.

– To evacuate the air outlet, please comply with the pertaining rules given by competent authorities.

– Provide the room with an adequate aeration when a cooker hood and appliances fed by energy other than electric power (gas-, oil-, or coal-stoves, etc.) are used simultaneously. The cooker hood, when evacuating the sucked air, could generate a negative pressure in the room- which can't exceed the limit of 0.04 mbar, in order to avoid the suck of exhausts deriving from the heat-source. Therefore the room should be provided with air-intakes to allow a constant flow of fresh air.

If the rating table in the cooker-hood shows the symbol , the appliance is built in class II° and it **does not need** any earth connection.

If the rating table in the cooker-hood **does not** show the symbol , the appliance is built in class I° and it **needs** the earth connection.

– When performing the electrical connections on the appliance, please make sure that the current-tap is provided with earth connection and that voltage values correspond to those indicated on the label placed inside the appliance itself.

– Before carrying out any cleaning or maintaining operations, the appliance needs to be removed from the electric grid. If the appliance is not provided with a non-separable flexible cable and plug, or with another device

ensuring omnipolar disconnections from the grid, with an opening distance between the contacts of at least 3 mm, then such disconnecting devices must be supplied within the fixed installation.

If the fixed appliance is endowed with a supply cord and a plug, the appliance has to be put in a place where the plug can be reached easily.

– The use of materials which can burst into flames should be avoided in close proximity of the appliance. When frying, please pay particular attention to fire risk due to oil grease. Being highly inflammable, fried oil is especially dangerous. Do not use uncovered electric grills. In order to avoid possible fire risk, all instructions for grease-filter cleaning and for removing eventual grease deposits should be strictly followed.

USES

The appliance is already arranged both for filtering and for suction performances.

– In its **filtering version** (Fig.1), the air and fumes conveyed by the appliance are depured both by a grease filter and by an active coal filter, and put again into circulation through the hole made on the top of the cabinet.

– In its **sucking version** (Fig.2), fumes are directly conveyed outside, through an evacuation duct connected with the superior part of the wall or the ceiling. Both coal filter and air deflector are not necessary in this case.

INSTALLATION SL906

Before installing the appliance, make sure that none of the parts is damaged in any way. In case of damaged parts, contact your retailer and do not proceed with installation. Read all of the following instructions with care before installing the appliance.

– Use an air outlet pipe of the shortest possible length.

- Limit the number of pipe bends.
- Use a material approved by standards and regulations.
- Avoid any sudden changes in pipe section (recommended constant diameter: Ø 150 mm / Ø 200 mm or equal surface area).

- Before installing the appliance, in order not to damage the appliance itself, the metal grease filter should be removed. These filter could be removed by pushing the handles towards the back side of the cooker hood and turning it downwards to unfasten it from its slot. (Fig.3).

To install the appliance please respect the follow instructions.

The appliance must be install by competent authorities. In order to do not damage the electronic parts of the appliance please do not use added screws.

Essential precautions to respect before installing the appliance are the following:

To have made a cut-out on the bottom of the cabinet which is suitable to hold the appliance in position (dis. 4):

- SL906 da 600 501x265mm,
- SL906 da 850 826x265mm,
- SL906-L da 850 835x265mm,
- SL906 da 1000 985x265mm,
- SL906 da 1200 1100x265mm.

- prepare the power supply.
- prepare a hole for the exhaust of the air both in the filtering and in the exhausting version.

- Use an exhausting pipe whose maximum length does not exceed 5 meters.

Do not use screws to fix the outlet pipe to the cooker hoods.

- Limit the no. of elbows in the piping , since each elbow reduces the aspiration efficiency of 1 linear meter. (Ex.: if you use no. 2 x 90 ° elbows, the length of piping l must not exceed 3 meters)
- Avoid abrupt direction changes.
- Use a 150 mm constant diameter pipe for the whole length.
- Use piping approved by standards in force.

In the units equipped with 2 motors please use a 200mm constant diameter pipe for the whole length.

To install the appliance, adjust the position of the stop side-springs using the appropriate

screws (fig.5), according to the thickness of the board previously drilled, on which the appliance will be fixed.

Insert the built-in unit in the hole made in the cabinet until the stop click of the side-springs is heard and the built-in unit is blocked. Insert the screws provided in the holes inside the appliance (fig.6) to block it completely.

Put the grease filter again

Blocking of the stop valve

Warning!

Before connecting the flexible exhausting pipe to the motor, make sure the stop valve, which is on the air outlet of the motor, can swing.

Exhausting version

Connect the flange to the exhausting hole with an appropriate pipe. Connect the appliance with the electrical mains through the supply cord.

Filtering version

Connect the flange with a pipe suitable to convey the air to the top of the cabinet. Connect the appliance with the electrical mains through the supply cord.

Rear vented version

All the models with one motor can be rear vented; if the customer wants to use this option, it is necessary to remove the 18 screws from the motor group support. Then take the metal support with motor included out (pic. 11a). Turn the motor to have the air outlet on the rear side (pic. 11b) and fix the screws previously removed.

INSTALLATION SL907

Before installing the appliance, make sure that none of the parts is damaged in any way. In case of damaged parts, contact your retailer and do not proceed with installation. Read all of the following instructions with care before installing the appliance.

- Use an air outlet pipe of the shortest possible length.
- Limit the number of pipe bends.
- Use a material approved by standards and regulations.
- Avoid any sudden changes in pipe section (recommended constant diameter: Ø 150 mm / Ø 200 mm or equal surface area).

Before carrying out installation, please remove the grease filter in order to avoid possible damages to the appliance. Please follow the following steps to remove the metal grease filter: open the lighted panel first, by turning it downwards (fig.12), then remove the grease filter by operating on its handle and making the filter rotate downwards, disengaging it from its seat.

Make a hole on the surface of the following dimensions (dis. 16):

270mm x 498mm for **SL907 52cm** model
270mmx675mm for **SL907 70cm** model

Insert the SL907 unit, making sure the push-button panel is placed on the right , looking at the product from the front of the cook-top.

Make the electric connection and connect the air-outlet flange to a suitable exhausting pipe.

Fix the unit by using the four screws provided and tighten them as shown in fig. 13.

Insert the grease filter again and close the perimeter panel.

WORKING

Mod. S906-S907 (fig. 10)

- A: Light switch on/off
- B: Motor switch on speed 1/off
- C: Motor switch on speed 2
- D: Motor switch on speed 3
- E: Motor switch on speed 4
- F: 10-minutes timer

MAINTENANCE

- An accurate maintenance guarantees good functioning and long-lasting performance.

- Particular care is due to the grease filter panel. It can be removed by pushing its special handle toward the back-side of the cooker hood and turning the filter downwards so to unfasten it from its slot (Fig.3).

To insert the filter just perform the opposite operation.

After 30 hours working, the push button control panel will signal the saturation of the grease filter by lighting all the buttons. Press the timer button to reset .

The grease filter needs cleaning by regular hand-washing or in dishwashers every two months at least or depending on its use.

- In case the appliance is used in its filtering version, the active coal filter (Fig.7) needs to be periodically replaced. The coal filter can be removed by removing the grease filter first (Fig.3), and by pulling its special plastic tongue until it is unfastened from its slot. Re-insert the coal filter by operating in the opposite way.

The coal filter needs replacing depending on the use, but however every six months at least.

- How to remove the oil collector. After having removed the grease filters and eventually the active coal filters, please hold the oil tank up by one hand and loosen the three handles by the other hand as showed in fig.8. Then let the tank slide downwards making attention in order to avoid the leak of oil.

- To clean the appliance itself tepid water and neutral detergent are recommended, while abrasive products should be avoided. For steel appliances specialized detergents are recommended (please follow the instructions indicated on the product itself to obtain the desired results).

- **Warning!** To take down the appliance from the cabinet, remove the definitive fixing screws (fig. 6) using a screw-driver, get off the grease filters (fig.3) and the active carbon filters, if they are inserted (fig. 7).

Act on the small handle of the springs, which are inside the built-in unit, with the necessary strength to unhook the appliance from the cabinet.

* If the supply cord is damaged, it must be replaced by the manufacturer or its service agent or a similarly qualified person in order to avoid a hazard.

Replace the dichroic lamp SL906, remove the lamp (fig.9) by inserting a screwdriver or another sharp tool between the lamp and its chrom support and replace it with a lamp of the same kind.

Replace the led bar SL 906-L

Before to replace the led bar switch off the appliance then by using appropriate tools remove the led bar from its slot (fig.17).

Take out the led bar from its connector and replace with similar characteristics.

To find the correct led bar please check on the replacement part list.

Replacement of SL 907 fluorescent lamp

To replace the fluorescent lamps of SL907 model, you need to open the perimeter panel, by rotating it as shown in Fig. 11, remove the panel fixing screws (fig. 13), paying special care in holding it during this step, then remove the lamps and replace the damaged one (fig. 14).

Insert the panel again.

If the supply cord is damaged, it must be replaced by the manufacturer or its service agent or a similarly qualified person in order to avoid a hazard.

WIRING DIAGRAM SL-EM906

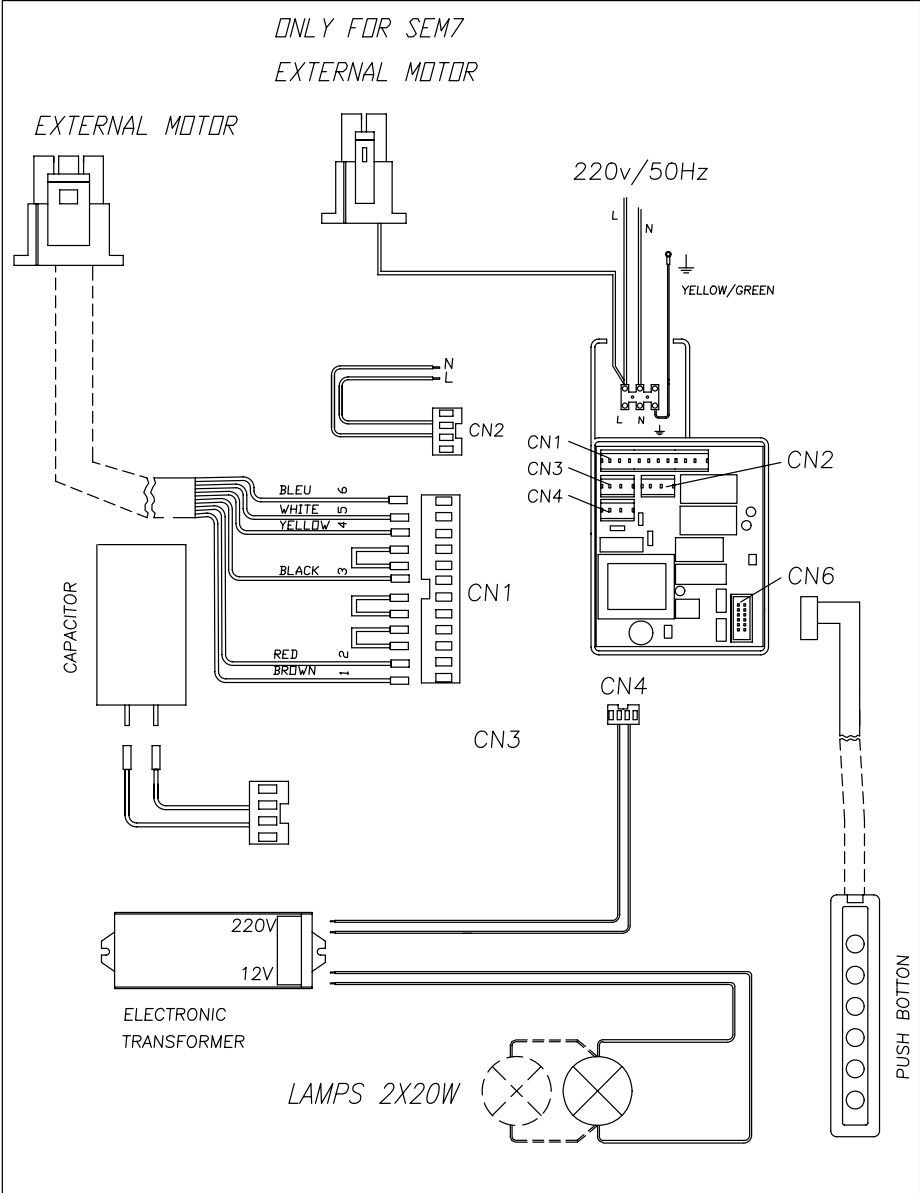

WIRING DIAGRAM SI906 1motor

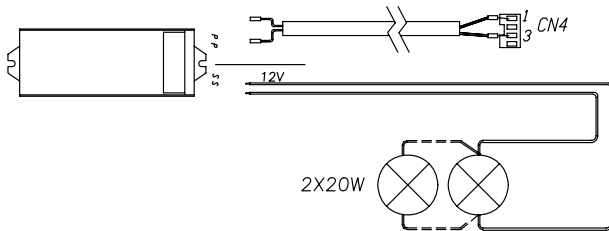
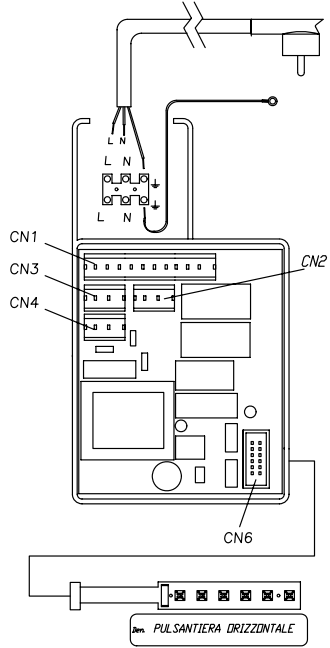
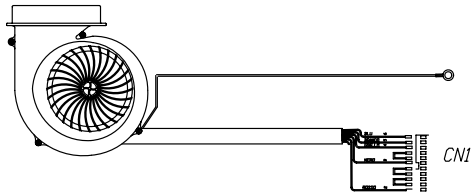
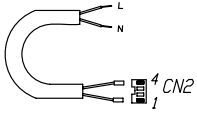
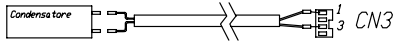

WIRING DIAGRAM SI906 2motors

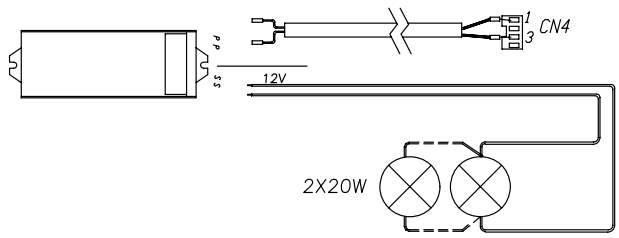
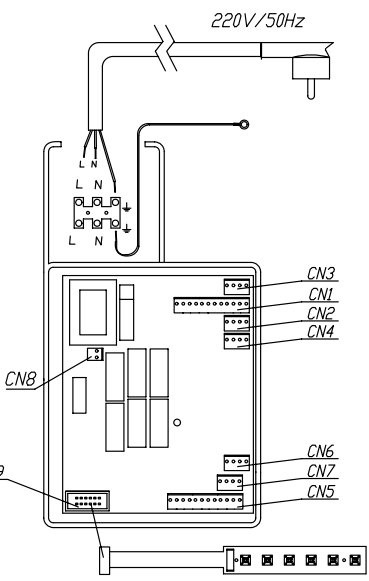
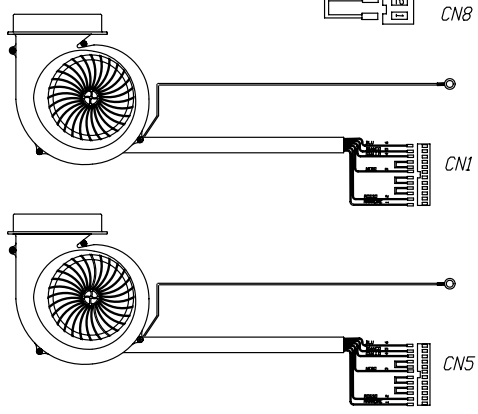
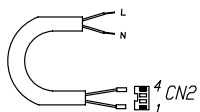
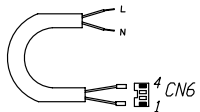
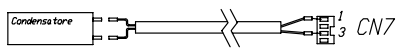
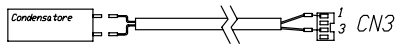

WIRING DIAGRAM SL906-L 1motor

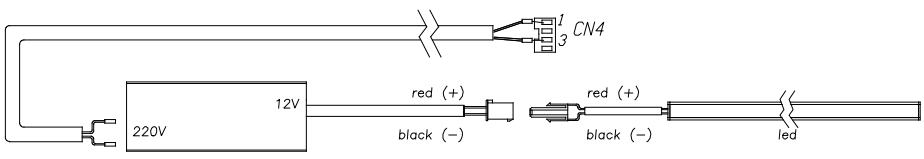
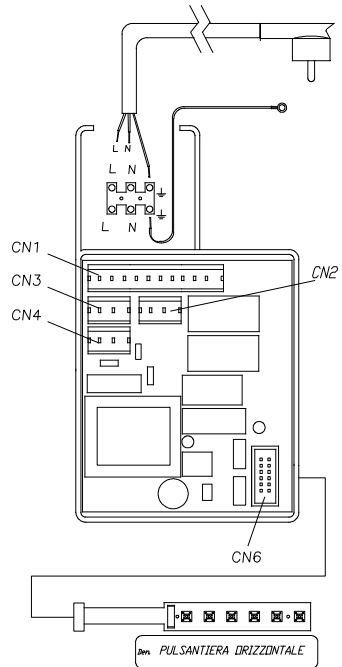
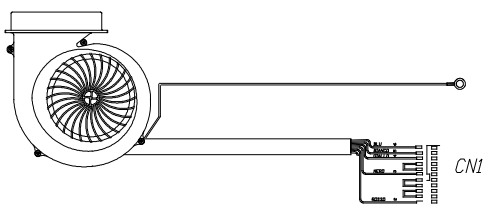
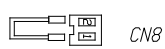
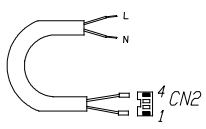
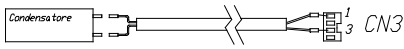

WIRING DIAGRAM SL906-L 2motors

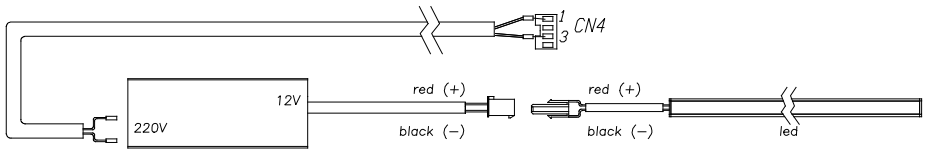
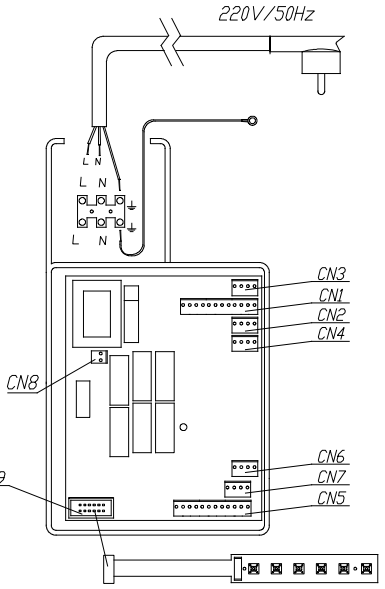
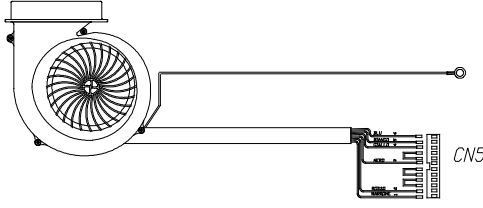
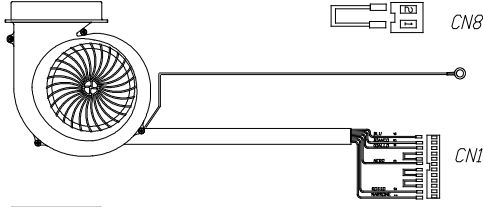
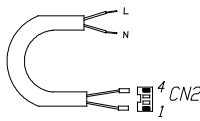
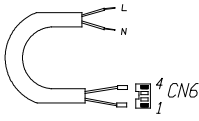
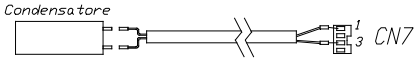
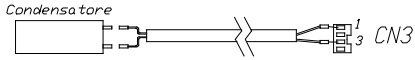

WIRING DIAGRAM SL-EM906-L

ONLY FOR SEM7
EXTERNAL MOTOR

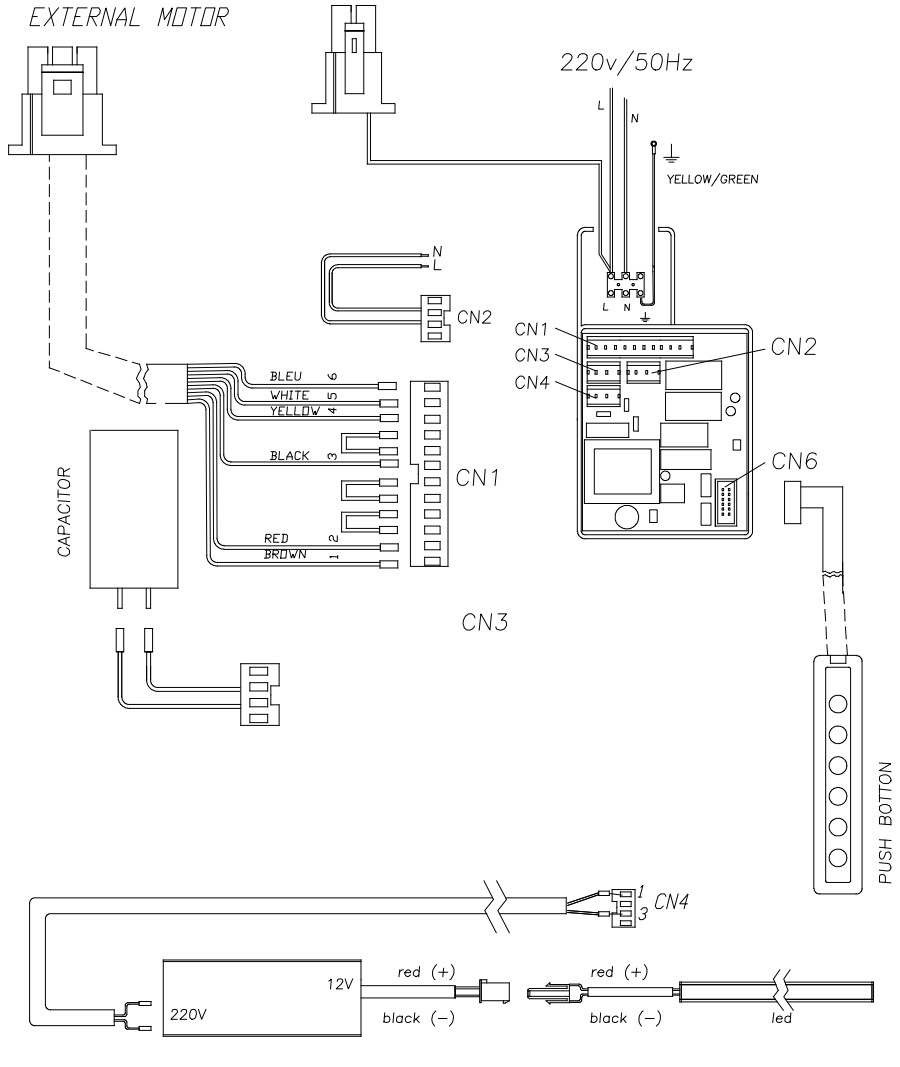

WIRING DIAGRAM SL907

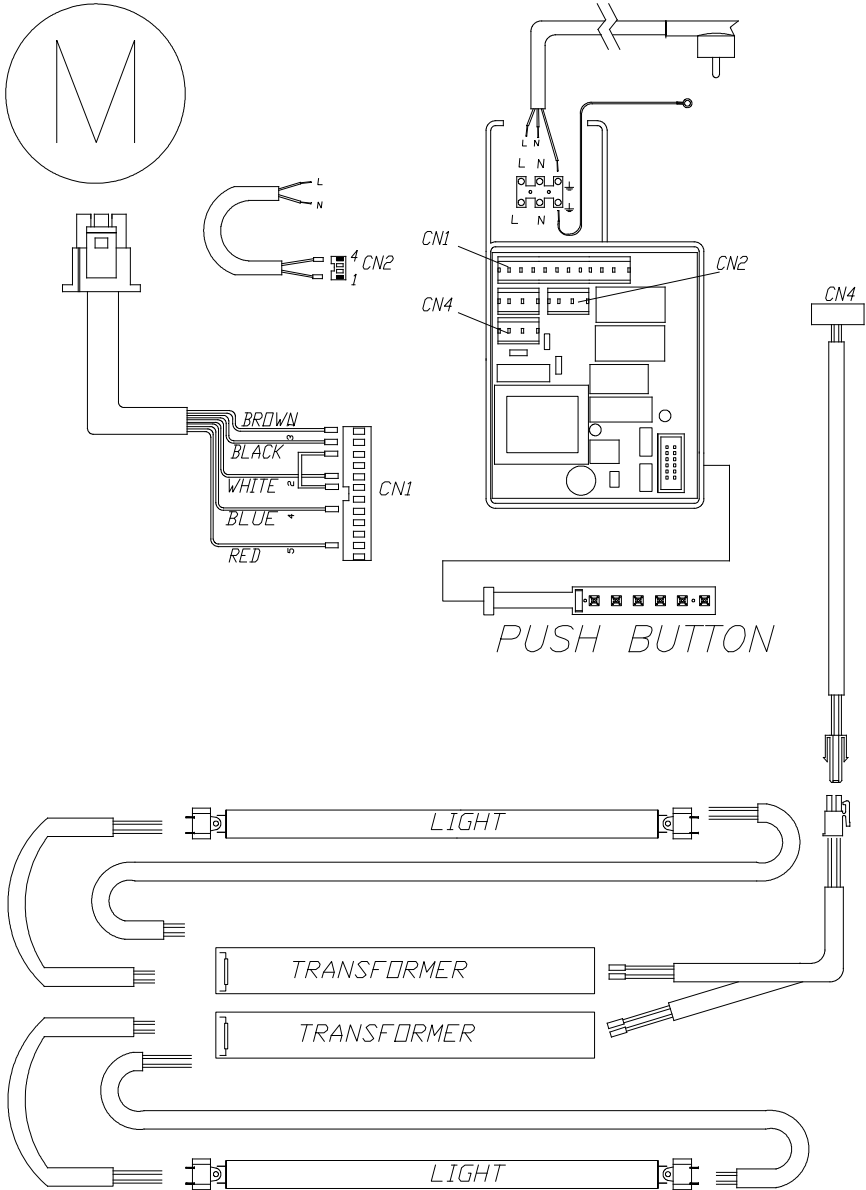

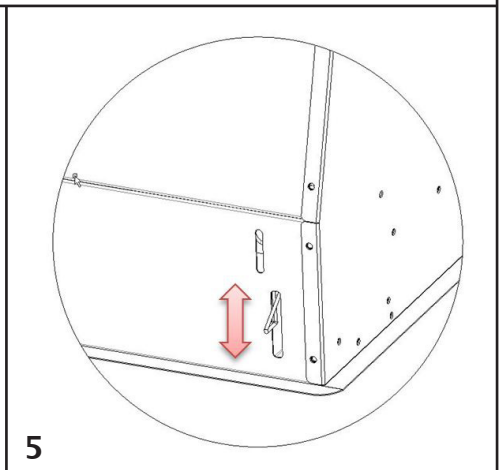
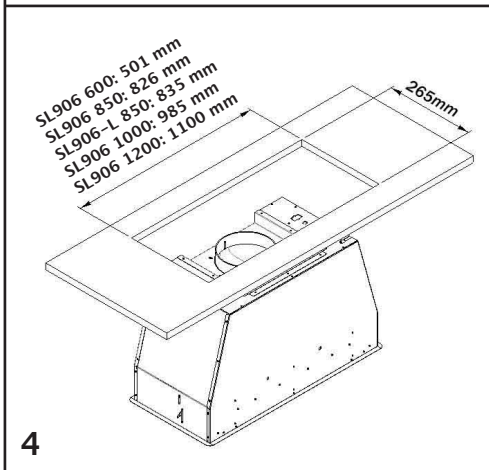
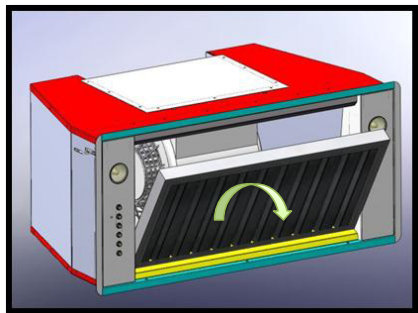
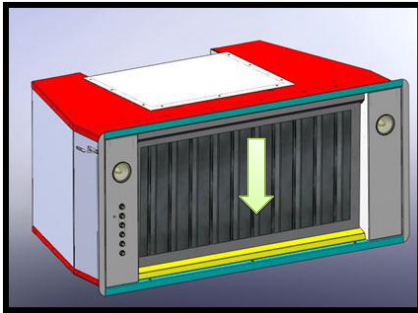
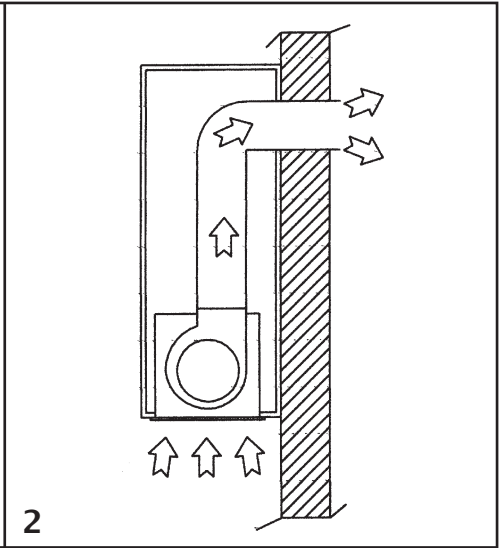
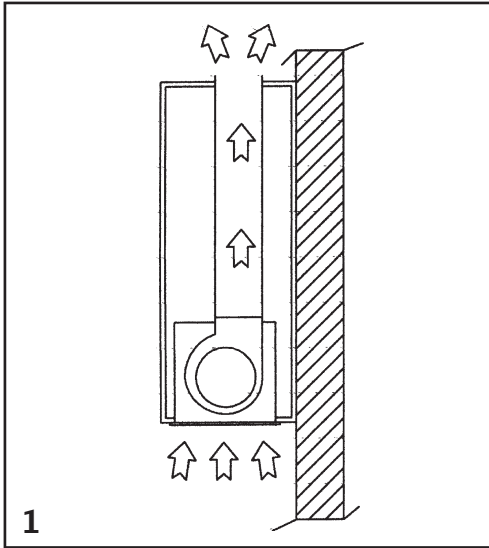

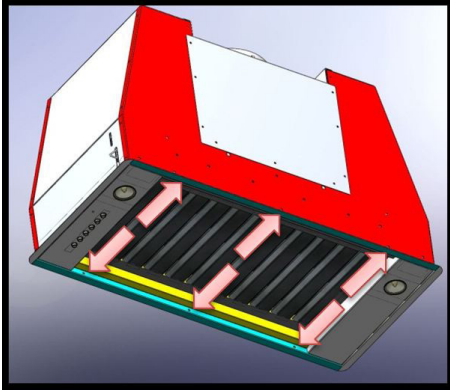

6

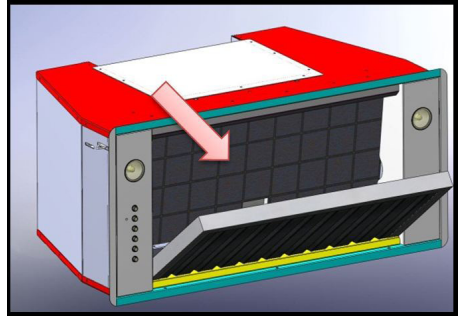

7

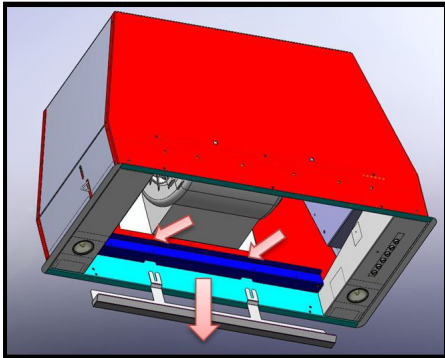

8

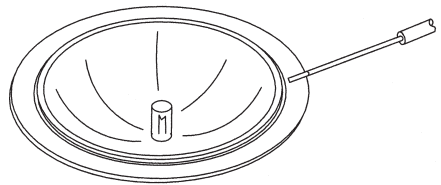

9

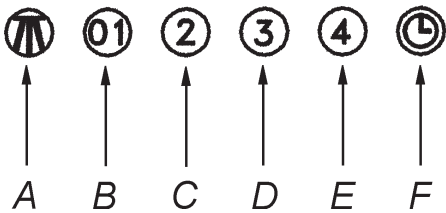

10

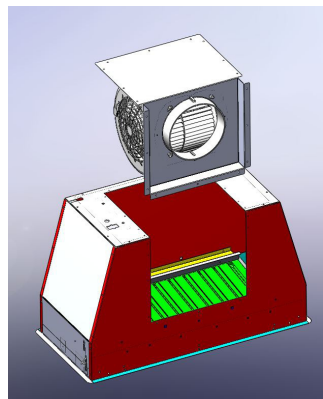

11a

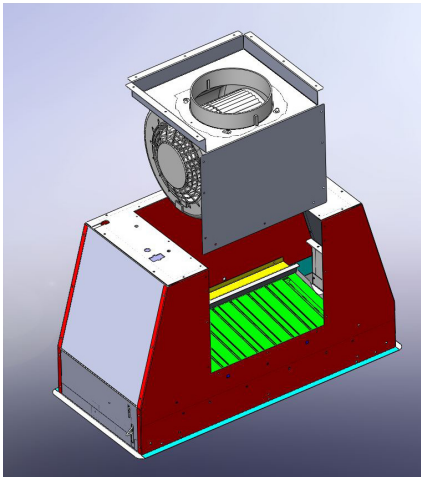

11b

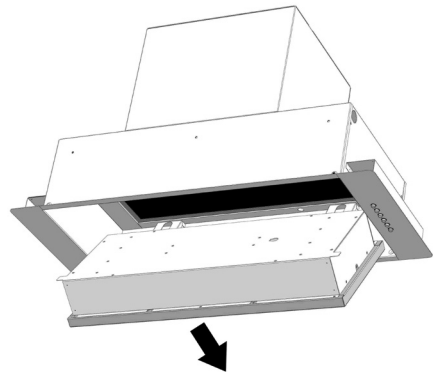

12

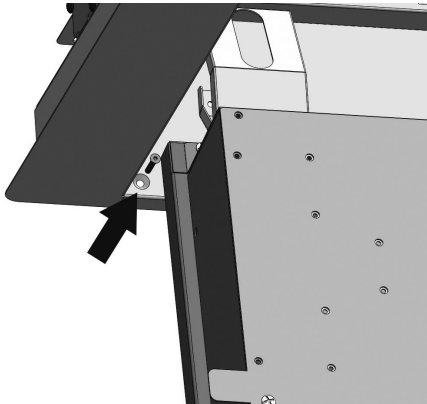

13

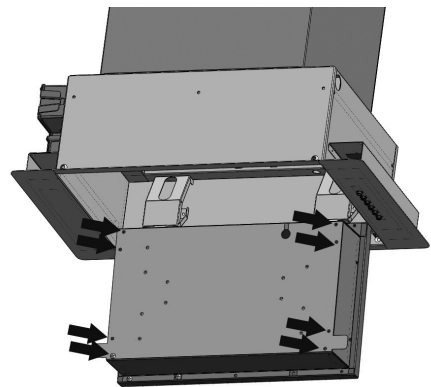

14

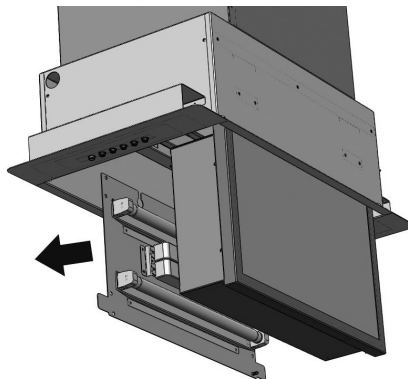

15

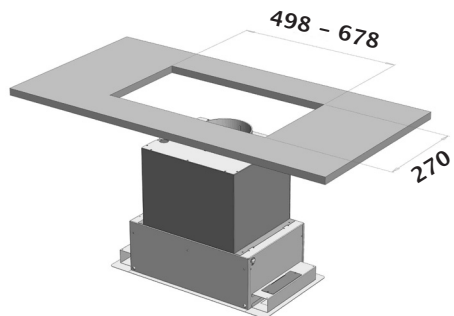

16

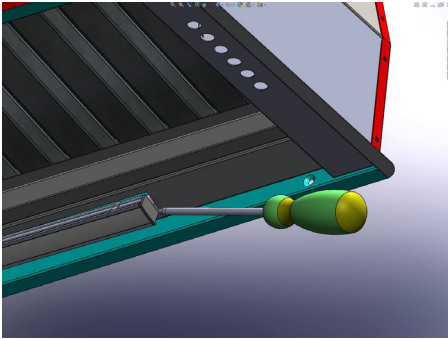

17

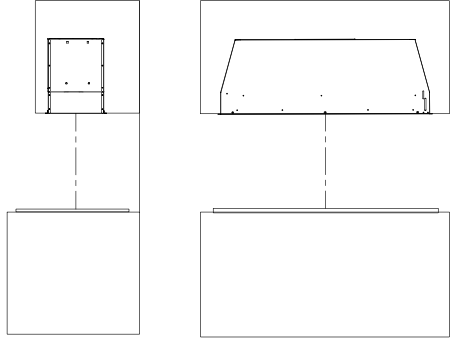

18

