

OPERATION AND INSTALLATION

DHW HEAT PUMP

- » WWK 300 A
- » WWK 300 AH

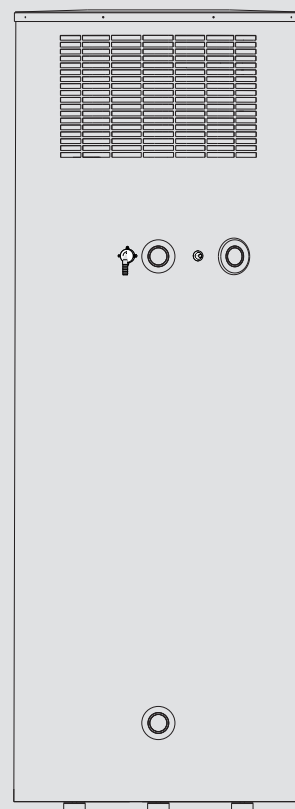

STIEBEL ELTRON

Contents

1. Operating instructions for users and contractors	3
1.1 Operation and control	3
1.2 Device description	3
1.3 Correct operation	3
1.4 Incorrect operation	3
1.5 Function description	3
1.6 Operation with active defrost feature WWK 300 A and WWK 300 AH	3
1.7 Maintenance and cleaning	4
1.8 Troubleshooting by the user	4
2. Installation instructions for contractors	5
2.1 Regulations and standards	5
2.2 Installation	6
2.3 Water connection	6
2.4 Power supply	8
2.5 Commissioning	8
2.6 Safety equipment and maintenance	8
2.7 Specification	10
2.8 Operation with active defrost feature	11
2.9 Wiring diagrams	12
2.10 Dimensions and connections	14
Warranty	15
Environment and Recycling	15

Symbols used in these instructions

Observe the following safety instructions:



Please note: Warning about possible dangers.



Note: Important information and tips.



Note: Carefully read these operating and installation instructions and keep them safe. Should the equipment change hands, pass these instructions to the subsequent owner. Pass them to the trained contractors for servicing purposes.

Positioning, installation and commissioning must be carried out by trained personnel working in accordance with these operating and installation instructions.



The appliance may be used by children aged 8 and up and persons with reduced physical, sensory or mental capabilities or a lack of experience provided that they are supervised or they have been instructed on how to use the appliance safely and have understood the resulting risks. Children must never play with the appliance. Children must never clean the appliance or perform user maintenance unless they are supervised.



Note: All measurements are given in mm unless stated otherwise.



1. Operating instructions for users and contractors

1.1 Operation and control

The Stiebel Eltron domestic hot water heat pump WWK 300 A/AH (DHW) is a DHW generator that operates automatically and has a capacity of approx. 300 l. The water temperature is permanently set to 60 °C.

The device is installed, connected and handed over ready for use by a qualified contractor. Nevertheless, you should familiarise yourself with the most important technical features of your heat pump.

1.2 Device description

The device extracts heat from the ambient air.

This energy is used to heat the water inside the cylinder. Where the device is installed inside a room, this is cooled down through the heat extraction by approx. 1 to 3 °C. The device also extracts moisture from the ambient air that creates condensate, which must be drained off. For this purpose, a condensate drain is integrated into the unit.

Special features of the WWK 300 AH

An electric booster heater is integrated for heating approx. 100 litres of water in the upper sector of the DHW cylinder.

1.3 Correct operation

The DHW heat pump is designed for extracting heat from the ambient air and the utilisation of that energy for heating domestic hot water. The DHW heat pump can be installed in the open as well as in enclosed spaces.

The appliance is intended for domestic use, i.e. it can be used safely by untrained persons. The appliance can also be used in a non-domestic environment, e.g. in a small business, as long as it is used in the same way.

1.4 Incorrect operation

The following are not permitted:

- The utilisation of greasy extract air.
- The heating of liquids other than domestic hot water.
- The installation of the equipment:
 - a) in rooms where the temperature is below the freezing point.
 - b) in rooms where the device is at risk from explosions as a result of dust, gases or vapours.
- Operation of the device with an empty cylinder.



Always operate the unit with a full water tank, otherwise high pressures will develop in the refrigeration system, causing it to shut down. A manual reset will be necessary afterwards to restart the unit.

1.5 Function description

Heat pump operation

This is the standard operating mode, to which the limits of scope of the heat pump apply (see: Specification). To heat up the cylinder capacity of approx. 300 litres of water in accordance with EN 255 part 3 to 60 °C, the WWK 300 A requires:

$\tau_{\text{Heat-up}}$	ϑ_{Room}	F_{rel}	$\vartheta_{\text{Cold water}}$	COP (t) WWK 300 A
10.1 h	15 °C	70 %	15 °C	3.19/3.3
5 h	42 °C	70 %	15 °C	5.61



If the heat pump is switched OFF and ON again, for instance after a power failure, the compressor will only re-start (after approx. 3 minutes), when the pressure inside the refrigerant circuit has normalised again.

Electric booster heater (only for the WWK 300 AH)

If there is a higher DHW demand or the WWK was switched OFF because you require hot water quickly, you can accelerate the heat-up process by means of the electric booster heater. For reasons of saving energy, the electric booster heater will only heat up approx. 100 litres of water in the upper section of the cylinder.

The control thermostat of the electric booster heater is preset to 60 °C and will be restarted when the DHW temperature falls below 45 °C. This safeguards not only that primarily the heat pump provides hot water, but also that you enjoy a high level

of DHW convenience when large amounts of hot water are drawn.

The red ON indicator illuminates when the electric booster heater is switched on.

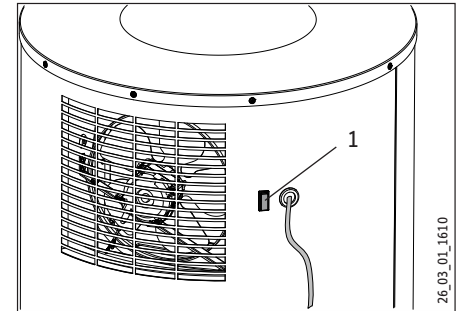

1 Red indicator

1.6 Operation with active defrost feature

WWK 300 A and WWK 300 AH

Subject to the relative humidity and the DHW temperature, the evaporator begins to build up hoar frost at an ambient temperature of below 6 °C.

If the evaporator is covered in hoar frost, the frost monitor N2 (see wiring diagram) switches the fan OFF, whilst the compressor continues to run, and the changeover valve V2 routes the hot gas directly to the evaporator. For this, the condenser is shut off by changeover valve V1 (see Fig. 4). When the temperature at the evaporator fins rises above 3 °C, the fan is started again, and DHW heating continues.

The DHW heat pump can be operated at ambient temperatures as low as 0 °C.

The evaporator is defrosted according to demand in the temperature range 0 °C to +6 °C. This extends the heat-up time.

Ambient temperature



The heat pump must not be installed in areas where ambient temperatures frequently exceed 42 °C or areas where temperatures frequently drop below 0 °C.

1.7 Maintenance and cleaning

The device is generally maintenance free, with the exception of cleaning the condensate drain and having an authorised contractor check the sacrificial anode (as outlined below).

A damp cloth is sufficient for cleaning all plastic parts. Never use scouring or solvent-based cleaning agents.

 **PLEASE NOTE: Maintenance work, e.g. checking the electrical safety, must only be carried out by a qualified contractor.**

- Check at least monthly the condensate drain at the middle of the unit (see Fig. 1, number 13) and at the top the condensate pan drain (visual check, see Fig. 3, pos. 15). Remove contaminants and blockages immediately.
- For the WWK 300 AH, it is recommended that the electric booster heater be descaled from time to time. This will result in prolonged life for the electric booster.
- Your local contractor, who is familiar with the local water quality, should identify for you the timing of the next service.
- Ask your local contractor to regularly check the safety assembly and the electric booster heater.
- The device is subject to mains water pressure. The expansion water drips from the safety valve during heat-up. Inform your local contractor of water drips from the system after the heat-up process has ended.

 **PLEASE NOTE: The sacrificial anode must be checked by a qualified contractor 12 months after the unit has been installed and checked periodically thereafter as advised by the qualified contractor. Failure to do so may void your warranty.**

- To protect the steel cylinder against corrosion, the interior is coated with a special enamel and is furthermore equipped with a protective anode. Ask your local contractor to check the protective anode 12 months after installation and periodically thereafter as advised by your local contractor. A sacrificial anode maintenance log is located at the end of this manual for your local contractor to fill in.

1.8 Troubleshooting by the user

No hot water

Should you fail to obtain hot water at any time, you can take the following steps to remedy that situation.

No electrical power

Check the fuse/circuit breaker in your fuse box. If it has blown/tripped, replace/reset the fuse/MCB. If it should blow/trigger repeatedly, notify your local contractor.

Still no hot water, even though power is available

Check, whether the air inlet/outlet is blocked.

The thermostitch trips out or the high limit safety pressure limiter switches the compressor OFF if the compressor is overloaded due to excessive ambient temperature or excessive air temperature (>42 °C), or because of a fault in the refrigerant circuit. Ask your local contractor to remove the fault.

After a short cooldown phase, the thermostitch will restart the compressor automatically.

 **The high limit safety pressure limiter must only be reset by your contractor after he has removed the cause of the relevant fault.**

Other issues

Safety valve of the cold water supply line drips

This may occur during the heat-up phase and is completely normal.

The condensate drain drips

This always happens when the surface temperature of the evaporator is lower than the ambient dew point temperature.

For all other faults, consult your contractor.



2. Installation instructions for contractors

2.1 Regulations and standards

- The installation (water and electrical work) and commissioning, as well as the maintenance of this equipment, must only be carried out by an authorised qualified contractor in accordance with these instructions.
- Perfect function and safe operation can only be assured when using original accessories and spare parts intended for this equipment.
- DIN VDE 0100 / DIN VDE 0701
- Regulations of your local electricity supply utility.
- DIN 1988 / DIN 4109
- Regulations of your local water supply utility.

The following standards were taken into account:

- AS 4234, AS 3498, AS 4020, AS 1056.1
- AS/NZS 2712, AS/NZS 3350.2.40/30/30.2
- IEC 60335-1-2-40, IEC 61000-3-2; 1995
- IEC 61000-3-3, IEC 55014-1 IEC 55014-2
- EMC Directive 89/336/EEC
- EN 255 T3

Also observe the following:

- The equipment type plate
- The specification
- Water installation
 - Observe the AS/NZS 3500. [local regulations].
 - **Material of the cold water line:** Steel, copper or plastic pipe systems.
 - **Material of the hot water line:** Copper or plastic pipe systems.

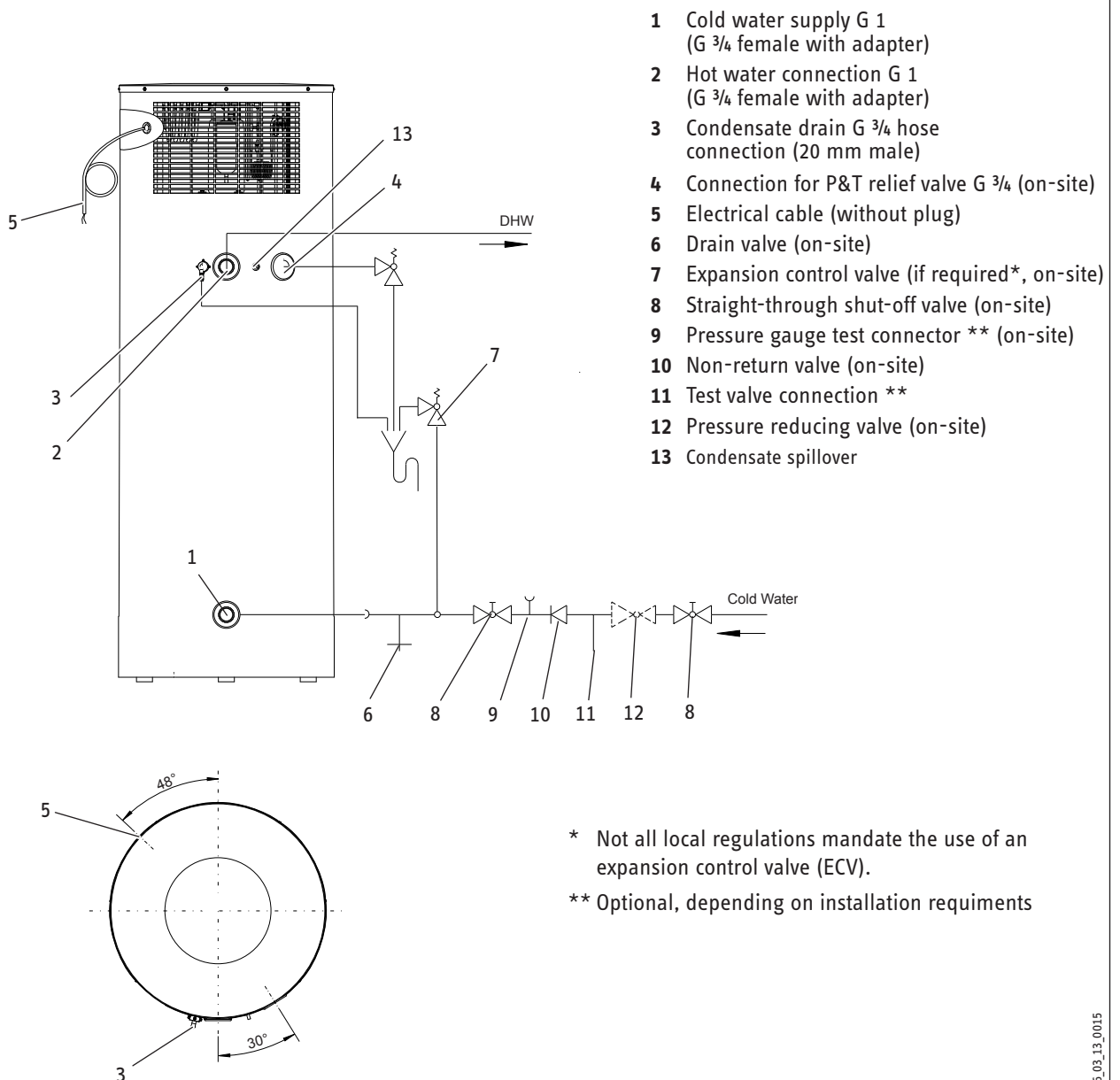

Fig. 1

* Not all local regulations mandate the use of an expansion control valve (ECV).

** Optional, depending on installation requirements

2.2 Installation

Transport

To protect the equipment against damage, it must be transported vertically inside its dedicated packaging. Where space is restricted, you may also briefly move the equipment tipped backwards at an angle.

Positioning

- Position the device in the installation location.

Note: Ensure that the casing panel in the lower area of the device is not damaged during positioning.

- Remove packing straps and polystyrene mouldings.
- Level the device by adjusting the equipment feet.
- After leveling the device fix the nut of the rubber feet to provide a maximum of structural safety.

External installation

The location where the WWK is to be installed must meet the following conditions:

- Load-bearing floor (wet weight of the WWK approx. 430 kg).
- Never operate the WWK in rooms at a risk from explosion due to dust, gases or vapours.
- It is preferred that the location of the unit is not near a bedroom or a neighbour's bedroom. Ideally a unit may be mounted near a kitchen or laundry. Opposite a neighbour's garage is always preferred.
- The water heater should be located as close as possible to the most frequently used hot water tap connection.
- Ensure that the data plate is clearly visible.
- Ensure that the ambient temperature lies within the application limits for heat pump operation.

Warning: The heat pump must not be installed in areas where ambient temperatures frequently exceed 42 °C or areas where temperatures frequently drop below 0 °C.

Installation locations with aggressive air (e.g. air loaded with ammonia, chlorine, metals, oil, ...) are inadmissible because they can cause damage to the device.

Where possible select an installation location that has limited exposure to extreme rain or snow.

Mount the unit so that it is not exposed to direct strong wind, but is well ventilated. The air inlet and outlet must be free. Protect your device with possibly a canopy, a base and baffles to weather.

Internal installation

The room where the WWK is to be installed must meet the following conditions:

- Load-bearing floor (wet weight of the WWK approx. 430 kg).
- Never operate the WWK in rooms at a risk from explosion due to dust, gases or vapours.
- Include in your considerations the utilisation of waste heat, for example from a boiler, tumble drier or refrigerator/freezer.
- The available floor area in the installation room must be at least 6 m². Never install this equipment in rooms with a volume of less than 13 m³.
- Never restrict the clearances of the WWK through walls and ceilings further than illustrated in Fig. 2.

Warning: The heat pump must not be installed in areas where ambient temperatures frequently exceed 42 °C or areas where temperatures frequently drop below 0 °C.

- In case of indoor installation and min. installation room volume, the room temperature might be reduced by approx. 1-3 °C through the heat pump operation. The initial temperature is reached again approx. 1/2 h after the heat pump has been switched OFF.

When installing the heat pump in a boiler room, ensure that the boiler operation will not be impaired.

Do not place the device near high frequency machines.

2.3 Water connection

- Remove the protective caps from the connectors.
- With a sharp knife, cut a hole into the protective caps and invert over the pipe to be connected.
- Connect the pipe and refit the protective caps.

Warning: Please note: To protect against the risk of corrosion, make the connection as flat packing seal. The use of hemp, teflon, or thread seal tape on connections is not acceptable.

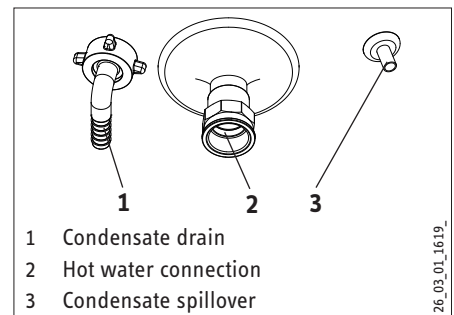

Positioning

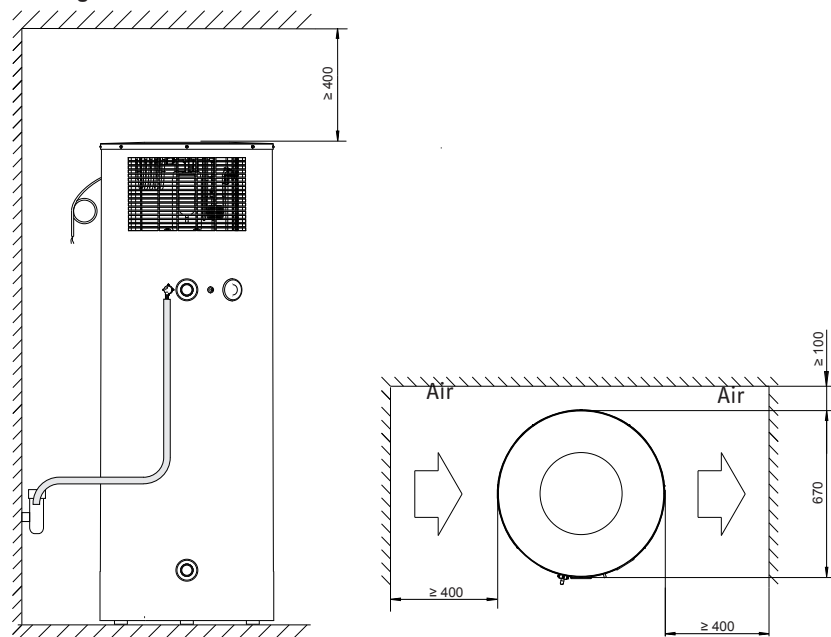

Insulate the DHW line in accordance with local regulations.

Accurately maintain the order of fittings on the cold water side (see Fig. 1).

Flush the line prior to installation.

Install a drain valve at the lowest point of the cold water supply inlet for future maintenance of the tank.

Install a 700 kPa pressure and temperature relief valve (PTRV) (Fig. 1, pos. 4).

Observe the requirements for expansion control valve (ECV) (Fig. 1, pos. 7). In such case, use a 550 kPa valve.

A pressure reduction valve (PRV) must be fitted (Fig. 1, pos 12) and adjusted to a maximum of 500 kPa. If the ECV is required, set PRV to a maximum of 420 kPa.

Please observe the following:

- Supply and drain pipe sizes should be equal to safety valve sizes.
- Size the drain so that water can drain off, even if the safety valve has been fully opened.
- The drain outlet must not be able to be closed and must always remain open to atmosphere.

Condensate drain

The device is designed so that, if it is installed externally, the condensate through a suitable drain hose can freely drain away. However, the condensate can also (in case of internal installation or local regulations) be routed away, to a garden bed, a drain in the floor or a wall drain.

Note: Never kink the hose, to ensure the condensate drains perfectly.

If required install a condensate pump.

WWK 300 A/WWK 300 AH:

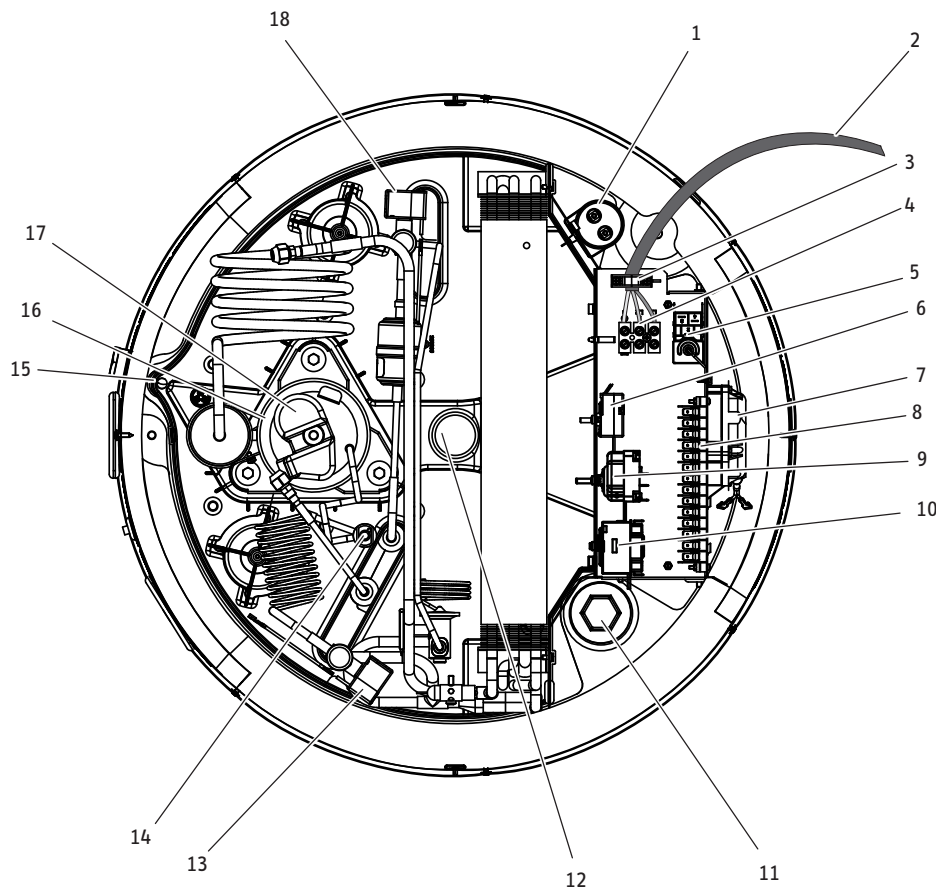



Fig. 3

26_03_01_1403

- | | | | |
|----|---|----|---|
| 1 | Capacitor | 11 | Electric booster heater (only for the WWK 300 AH) |
| 2 | Electrical cable | 12 | Protective anode (maintenance required) |
| 3 | Strain relief | 13 | Solenoid valve V1 |
| 4 | Power terminals | 14 | Safety high pressure limit |
| 5 | Frost monitor | 15 | Condensate pan drain (maintenance required) |
| 6 | Heat pump control thermostat | 16 | Compressor |
| 7 | Ventilator | 17 | Compressor motor protection (Klixon) |
| 8 | Heat pump terminal | 18 | Solenoid valve V2 |
| 9 | Control thermostat, electric booster heater, not shown, points at place (only for the WWK 300 AH) | | |
| 10 | High limit safety cut-out Electric booster heater (only for the WWK 300 AH) | | |

2.4 Power supply

Only qualified electricians must carry out the installation in accordance with these instructions.

 **Please note: Before any work, isolate the equipment from the power supply at the control panel.**

Observe VDE 0100 [or local regulations] and the regulations of your local power supply utility.

The appliance is intended to be permanently connected to fixed wiring. For the connection to the power supply the fitted supply cord has to be used. (Fig. 3, pos. 2)

The DHW heat pump must be able to be separated from the mains power supply by an additional isolator, which disconnects all poles with at least 3 mm contact separation. For this purpose, use contactors, mains isolators, fuses, etc. on site.

Terminals are located inside the control panel and become accessible by removing the equipment lid and the cover of the wiring chamber).

2.5 Commissioning

Only approved contractors may commission this equipment and instruct the owner in its use.

Commissioning

- Fill, vent and thoroughly flush the device.
- Check the safety assembly. Inform the user that water may drip from the safety valve whilst the water is being heated up.
- Switch ON the power supply

Note:

- Never operate the equipment outside the temperature range 0 °C to + 42 °C.

At temperatures below - 10 °C (e.g. transport/storage), the safety temperature cut-out may respond. Press the reset button after the temperature is much higher than -10 °C (Fig. 3, pos. 10).

2.6 Safety equipment and maintenance

Only qualified contractors must carry out the installation in accordance with these instructions.

On the equipment

In case of a fault, the safety equipment of the WWK 300 interrupts the relevant power circuit.

 **Please note: Before any work on the equipment, disconnect all poles from the mains.**

High limit safety cut-out (STB) electric booster heater

Equipment with electric booster heater is stopped if the DHW temperature exceeds 95 °C.

When the source of the fault has been removed, reset the high limit safety cut-out by pressing the reset button (Fig. 3, pos. 10). The heat pump top cover should be opened for access to this device as shown in Fig. 3.

Safety high pressure limiter (SDBK)

The safety high pressure limiter shuts down the compressor, if the pressure inside the refrigerant circuit exceeds the permissible maximum value. The safety high pressure limiter may also respond, if the appliance is operated above its permissible limit (>42 °C air temperature) or the control thermostat of the heat pump fails to respond. Reset the high pressure limit safety cut-out by pressing the reset button (Fig. 3, pos. 14), after the cause of the fault has been removed.

Protective motor thermoswitch

The protective motor switch will shut down the compressor, if it is overloaded because of excessive thermal load. Remove the relevant fault. After a short cool-down phase, the protective motor switch restarts the compressor automatically.

Protective anode

 **PLEASE NOTE:** The sacrificial anode must be checked by a qualified contractor 12 months after the unit has been installed and checked periodically thereafter as advised by the qualified contractor. Failure to do so may void your warranty.

An anode for the protection of the DHW cylinder is inserted centrally from the top into the DHW cylinder of the appliance (Fig.3, pos. 12). The anode fitted at the factory (anode rod) is approximately 1.26 m long.

Replace the anode with a new one if the installed one has been consumed.

A cap over the anode terminal prevent the ingress of water between the anode terminal and the condensate pan. Remove the cap if you need to remove the anode.

When installing the anode, ensure that the metallic conductor connection is correctly made. It's recommended for first anode inspection to happen one year after installation.

Consult with your water specialist, or contractor, for the optimum timing for inspections thereafter. Should it be impossible to insert a rod anode, you may have a sectional anode installed instead. In areas where total dissolved solids (TDS) in the water is outside the range 40-400 mg/l, the magnesium alloy anode supplied, M2, must be replaced. Use a high potential, M1, anode if TDS < 40 or an aluminium A5 alloy anode if TDS > 400, before installing the unit.

Push the cap back over the anode terminal.

Cleaning the evaporator

Maintaining the full output of the WWK 300 requires an occasional professional cleaning of the evaporator. Clean the evaporator only with water and a brush. Never use acidic or alkaline cleaning solutions.

**WARNING Injury risk**

The evaporator has many sharp-edged fins. When cleaning the evaporator, proceed with caution and wear protective clothing, in particular safety gloves.

Further information regarding the equipment:

- **Descaling (only if a booster heater is installed)**
 - Close the shut-off valve in the cold water supply to the tank.
 - Draw water from the tank to relieve the pressure inside the appliance.
 - Unscrew the booster heater flange. To undo the flanged immersion heater, you require a 1½" pipe wrench. The pipe wrench must be hollow so it can be guided over the connecting cables.
 - Immerse scaled sections of the heater rod into a descaling liquid (for example citric acid), until the limescale has dissolved from the heater rod.
 - Flush the descaling liquid off and allow the immersion heater to dry.
- **Draining the cylinder:**
 - Close the shut-off valve in the cold water supply.
 - Fully open the hot taps at all draw-off points.
 - The cylinder is drained via the cold water inlet line. Open the drain valve (fig. 1, pos. 6). If no drain valve was installed, undo the fitting on the cold water supply of the appliance. Residual water remains in the lower part of the cylinder.



Note: Hot water can be expelled during draining.

On the system**Safety valve (on-site)**

This valve opens when the water pressure exceeds the preset value of 0.7 MPa (7 bar) thereby relieving the pressure. It is adjusted so that no water will be expelled when heating is switched OFF. Should it continue to drip excessively, either the valve seat has become contaminated, the water pressure is too high or the pressure reducing valve has become faulty.

Pressure reducing valve (on-site provision)

Check the valve for perfect function. Replace it, if required.

Regular valve maintenance

Safety requires that valves are regularly checked for perfect function. For this, regularly vent the safety valve until a full stream of water flows from it. Close the safety valve after checking.

How quickly limescale builds up depends on the local water quality.

As your local contractor is familiar with your local water quality, let him determine the timing of this check.

**WARNING**

If the hot water unit is not used for two or more weeks, an amount of highly flammable hydrogen gas may accumulate in the water tank. To dissipate this gas safely, it is recommended that a hot tap be turned on for several minutes or until discharge of gas ceases. Use a sink, basin or bath outlet, but not a dishwasher, clothes washer or other appliance. During this procedure, there must be no smoking, open flame or any electrical appliance operating nearby. If hydrogen is discharged through the tap, it will probably make an unusual sound as with air escaping.

2.7 Specification

		WWK 300 AH	WWK 300 A
		227070	222422
Heat output			
Heating output at L15/F70/W55	kW	1,7	1,7
Power consumption			
Power consumption at L15/F70/W55	kW	0,5	0,5
Power consumption, emergency/booster heater	kW	1,69	
Coefficient of performance (COP)			
COP at L15/F70/W55		3,4	3,4
COPs to EN 255			
Coefficient of performance to EN 255		3,19	3,19
Sound data			
Sound pressure level at 1 m distance in a free field	dB(A)	56	56
Sound power level (EN 12102)	dB(A)	64	64
Application limits			
Min. installation room floor area	m ²	6	6
Min. installation room volume	m ³	13	13
Hydraulic data			
Rated capacity	l	300	300
Electrical details			
Fuses	A	C 10	C 10
Rated voltage	V	240	240
Phases		1/N/PE	1/N/PE
Frequency	Hz	50	50
Rated current	A	2,5	2,5
Power consumption	W	2250	700
Max. power consumption	W	2250	700
Versions			
IP-Rating		IP24	IP24
Refrigerant		R134a	R134a
Refrigerant capacity	kg	0,9	0,9
Dimensions			
Height of unit when tilted	mm	1990	1990
Height when tilted incl. packaging	mm	2200	2200
Height	mm	1870	1870
Diameter	mm	670	670
Weights			
Weight (dry)	kg	130	125
Weight (wet)	kg	432	428
Weight	kg	130	125
Connections			
Condensate drain	mm	20	20
Water connection		G 1 (with adaptor Rp 3/4 female)	G 1 (with adaptor Rp 3/4 female)
Values			
Air flow rate	m ³ /h	550	550
Lower air temperature limit	°C	0	0
Upper air temperature limit	°C	42	42

2.8 Operation with active de-frost feature

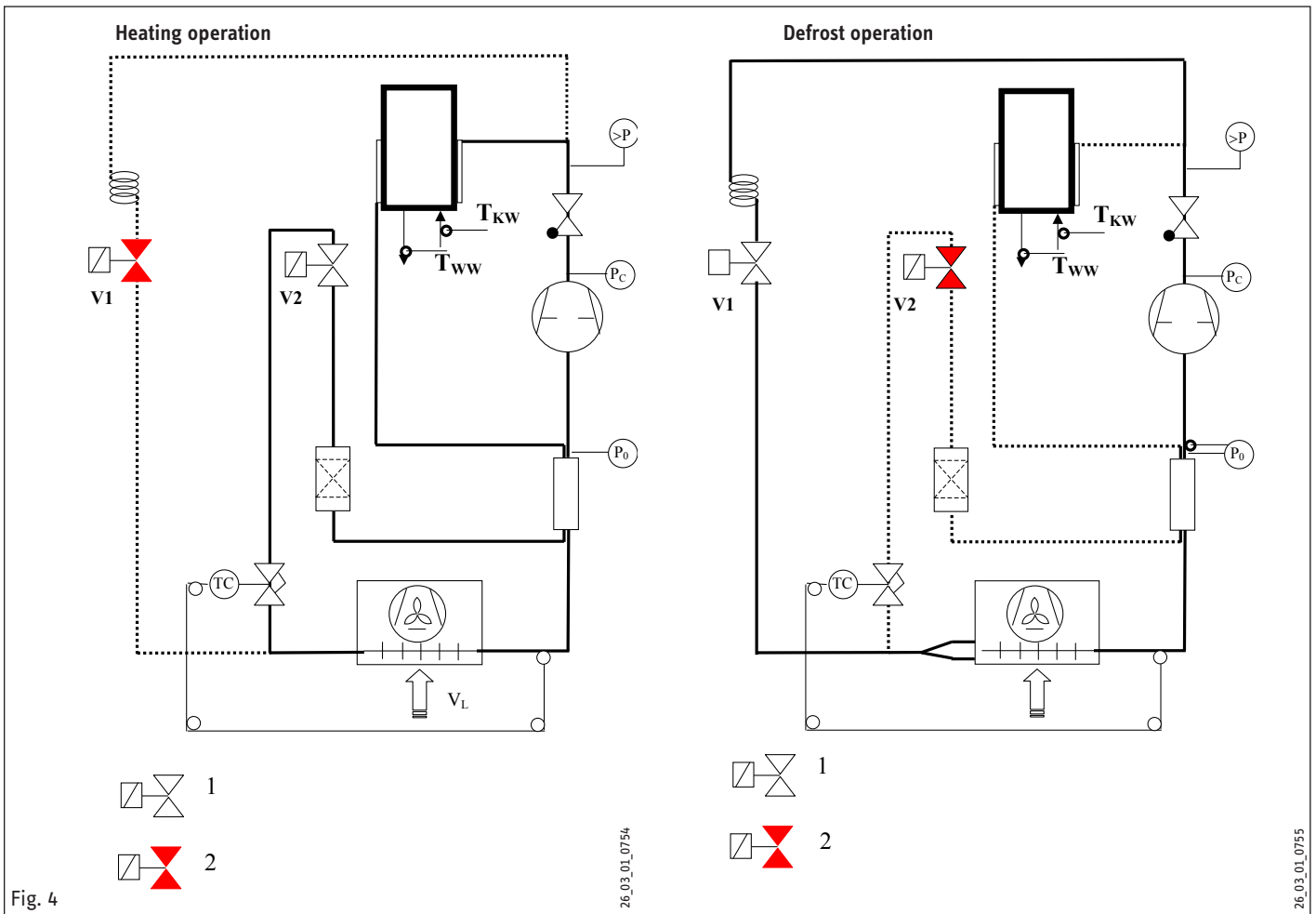

2.9 Wiring diagrams

2.9.1 WWK 300 A

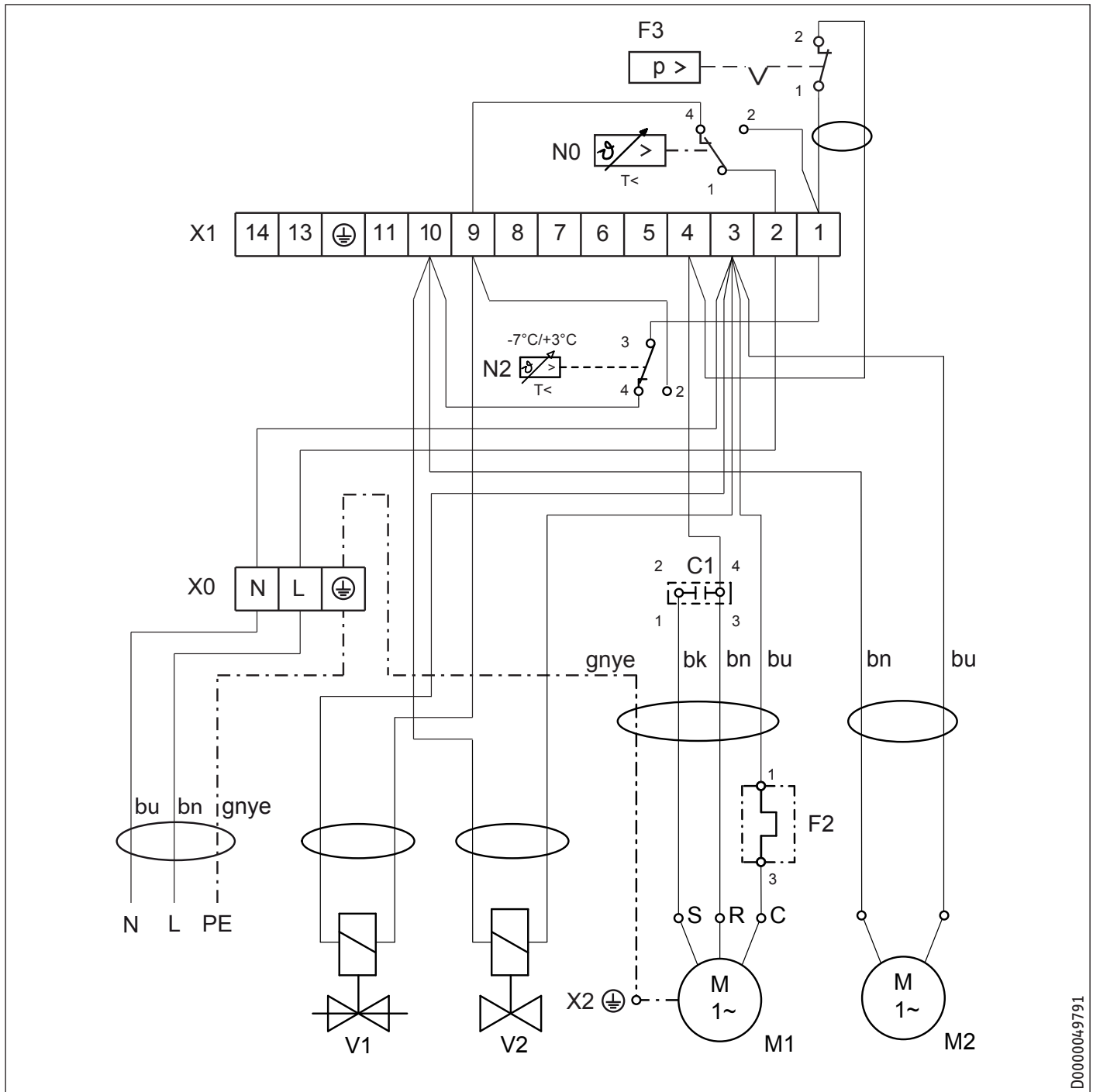

- C1 Capacitor
- F2 Compressor motor protection (Klixon)
- F3 High limit safety cut-out
- M1 Compressor
- M2 Fan
- N0 Heat pump control thermostat
- N2 Frost monitor
- V1 Solenoid valve
- V2 Solenoid valve
- X0 Power terminals
- X1 Heat pump terminals
- X2 Anode terminal earth

D0000049791

2.9.2 WWK 300 AH

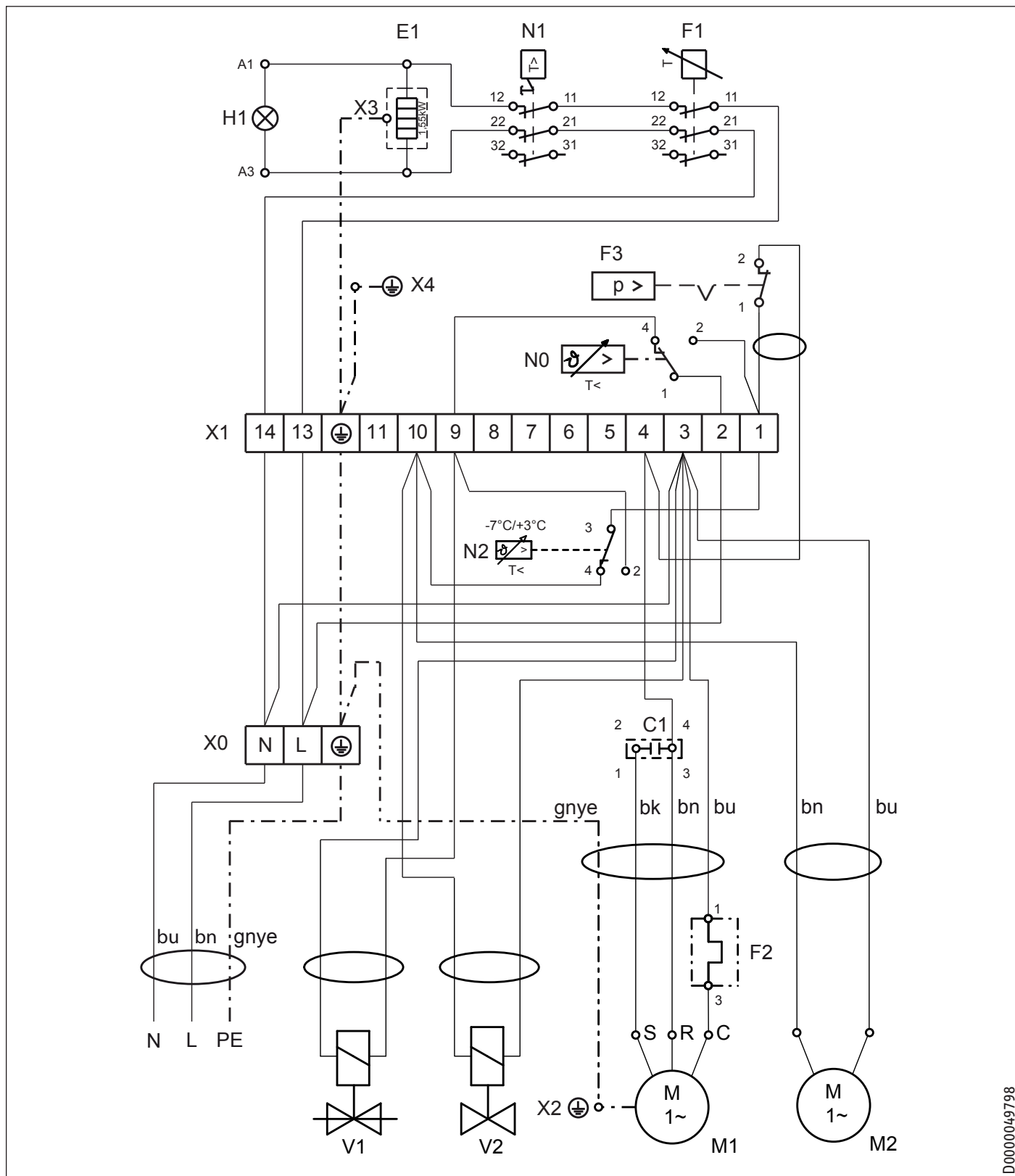

D0000049798

- | | | | |
|----|--|----|---|
| C1 | Capacitor | N0 | Heat pump control thermostat |
| E1 | Electric booster heater | N1 | Control thermostat, electric booster heater |
| F1 | High limit safety cut-out
Electric booster heater | N2 | Frost monitor |
| F2 | Compressor motor protection (Klixon) | V1 | Solenoid valve |
| F3 | Safety pressure limiter Heat pump | V2 | Solenoid valve |
| H1 | Signallamp electric booster heater | X0 | Power terminals |
| M1 | Compressor | X1 | Heat pump terminals |
| M2 | Fan | X2 | Anode terminal earth |
| | | X3 | Ground electric heating element |

2.10 Dimensions and connections

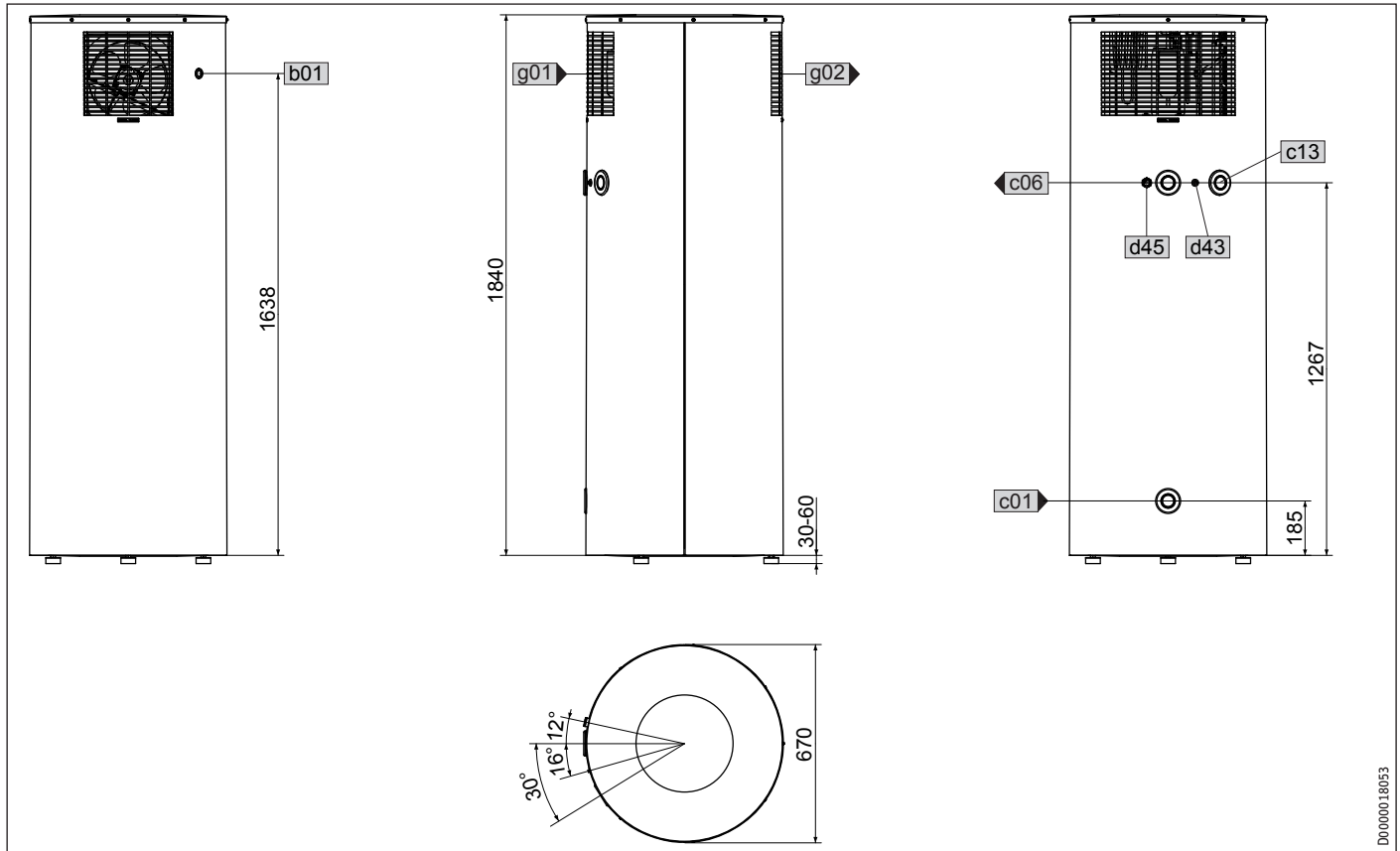

			WWK 300 AH	WWK 300 A
b01	Entry electrical cables			
c01	Cold water inlet	Male thread	G 1	G 1
c06	DHW outlet	Male thread	G 1	G 1
c13	T&P valve	Female thread	G 3/4	G 3/4
d43	Condensate overflow			
d45	Condensate drain	Male thread	G 3/4	G 3/4
g01	Air intake			
g02	Air discharge			

Accessories

Type	Part Number	Description
PK 10	229286	Condensate pump

Guarantee

The warranty conditions of our German companies do not apply to appliances acquired outside of Germany. In countries where our subsidiaries sell our products, it is increasingly the case that warranties can only be issued by those subsidiaries. Such warranties are only granted if the subsidiary has issued its own terms of warranty. No other warranty will be granted.

We shall not provide any warranty for appliances acquired in countries where we have no subsidiary to sell our products. This will not affect warranties issued by any importers.

Environment and recycling

We would ask you to help protect the environment. After use, dispose of the various materials in accordance with national regulations.

KYOTO | R134a

This device is filled with refrigerant R134a.

Refrigerant R134a is a CFC greenhouse gas mentioned in the Kyoto protocol with a global greenhouse potential (GWP) = 1300.

Never release refrigerant R134a to atmosphere.

Warranty Stiebel Eltron Australia Only - According to national regulations in Australia

Warranty for Heat Pumps – Models WWK 300A and WWK 300AH

Who gives the warranty

1. The warranty is given by Stiebel Eltron (Aust) Pty Ltd (A.B.N. 82 066 271 083) of 6 Prohasky Street, Port Melbourne, Victoria, 3207 (“we”, “us” or “our”).

The warranty

2. This warranty applies to Stiebel Eltron Heat Pumps – Models WWK 300A and WWK 300AH (the “unit”) manufactured after 1 January 2012.
3. Subject to the warranty exclusions we will repair or replace, at our absolute discretion, a faulty component in your unit free of charge if it fails to operate in accordance with its specifications during the warranty period.
4. If we repair or replace a faulty component to your unit under this warranty, the warranty period is not extended from the time of the repair or replacement.
5. The warranty period commences on the date of completion of the installation of the unit. Where the date of completion of installation is not known, then the warranty period will commence 2 months after the date of manufacture.
6. The warranty period for a unit used for domestic purposes is shown in the table below. Domestic purposes means that the unit is used in a domestic dwelling.

Component	Warranty period
Cylinder and condenser	5 years from the date of completion of the installation of the unit.
Sealed refrigeration system, including compressor, evaporator, valves and associated pipe work	2 years from the date of completion of the installation of the unit.
All other componentry (electrical)	1 year from the date of completion of the installation of the unit.

7. The warranty period for a unit used for commercial purposes is shown in the table below. Commercial purposes means that the unit is used for a non-domestic purpose and includes but not limited to being used in a motel, hotel, mining camp or nursing home.

Component	Warranty period
Cylinder and condenser	2 years from the date of completion of the installation of the unit.
Sealed refrigeration system, including compressor, evaporator, valves and associated pipe work	2 years from the date of completion of the installation of the unit.
All other componentry (electrical)	2 years from the date of completion of the installation of the unit.

Your entitlement to make a warranty claim

8. You are entitled to make a warranty claim if:
 - 8.1. you own the unit or if you have the owner’s consent to represent the owner of the unit;
 - 8.2. you contact us within a reasonable time of discovering the problem with the unit;

How you make a warranty claim

9. To make a warranty claim you must provide us with the following information:
 - 9.1. The model number of the unit;
 - 9.2. A description of the problem with the unit;
 - 9.3. The name, address and contact details (such as phone number and e-mail address) of the owner;
 - 9.4. The address where the unit is installed and the location (e.g. at side of house);
 - 9.5. The serial number of the unit;
 - 9.6. The date of purchase of the unit and the name of the seller of the unit;
 - 9.7. The date of installation of the unit;
 - 9.8. A copy of the certificate of compliance when the unit was installed.
10. The contact details for you to make your warranty claim are:

Name: Stiebel Eltron (Aust) Pty Ltd

Address: 6 Prohasky Street, Port Melbourne, Victoria, 3207

Telephone: 1800 153 351 (8.00 am to 5.00 pm AEST Monday to Friday)

Contact person: Customer Service Representative

E-mail: service@stiebel.com.au
11. We will arrange a suitable time with you to inspect and test the unit.

Warranty exclusions

12. We may reject your warranty claim if:
 - 12.1. The unit was not installed by a registered and qualified plumber.
 - 12.2. The unit was not installed and commissioned:
 - a) in Australia;
 - b) in accordance with the Operating and Installation Guide; and
 - c) in accordance with the relevant statutory and local requirements of the State or Territory in which the unit is installed.
 - 12.3. The unit has not been operated or maintained in accordance with the Operating and Installation Guide.
 - 12.4. The unit does not bear its original Serial Number or Rating Label.

- 12.5. The unit was damaged by any or any combination of the following:
- normal fair wear and tear;
 - connection to an incorrect water supply, for example where the water is highly conductive; where the water has a mineral content with a TDS > 2500 mg/L; or where the Langelier Saturation Index (LSI) of the water is outside the range $-1.0 < \text{LSI} < 0.8$ (The LSI is a numeric value indicating whether water is scale forming or corrosive. It factors in pH, total alkalinity, calcium hardness and water temperature);
 - connection to water from a bore, dam or swimming pool;
 - connection to an incorrect power supply;
 - connection to faulty equipment, such as damaged valves;
 - insufficient air flow;
 - foreign matter in the water supply, such as sludge or sediment;
 - corrosive elements in the water supply;
 - inappropriate anode or replacement regime used;
 - accidental damage;
 - act of God, including damage by flood, storm, fire, lightning strike and the like;
 - excessive water pressure, negative water pressure (partial vacuum) or water pressure pulsation.
- 12.6. The unit was damaged before it was installed e.g. it was damaged in transit.
- 12.7. An unauthorised person has modified, serviced, repaired or attempted to repair the unit without our consent.
- 12.8. Non genuine parts other than those manufactured or approved by us have been used on the unit.
13. We may charge you:
- for any additional transport costs if the unit is installed more than 30 kilometres from our closest authorised service technician.
 - for the extra time it takes our authorised service technician to access the unit for inspection and testing if it is not sited in accordance with the Operating and Installation Guide and not readily accessible for inspection.
 - for any extra costs of our authorised service technician to make the unit safe for inspection.
14. You must ensure that access to the unit by our authorised service technician is safe and free from obstruction.
15. Our authorised service technician may refuse to inspect and test the unit until you provide safe and free access to it, at your cost.
16. If we reject your warranty claim in accordance with clause 12, we may charge you for our authorised service technician's labour costs to inspect and test the unit.
17. In order to properly test the unit we may remove it to another location for testing.

Australian Consumer Law

- Our goods come with guarantees that cannot be excluded under the Australian Consumer Law. You are entitled to a replacement or refund for a major failure and compensation for any other reasonably foreseeable loss or damage. You are also entitled to have the goods repaired or replaced if the goods fail to be of acceptable quality and the failure does not amount to a major failure.
- The Stiebel Eltron warranty for the unit is in addition to any rights and remedies you may have under the Australian Consumer Law.

ENVIRONMENT AND RECYCLING

Please help us to protect the environment by disposing of the packaging in accordance with the national regulations for waste processing.

Sacrificial anode maintenance log



PLEASE NOTE: The sacrificial anode must be checked by a qualified contractor 12 months after the unit has been installed and checked periodically thereafter as advised by the qualified contractor. Failure to do so may void your warranty.

Date unit was installed

12 month sacrificial anode review date	Completed (yes/no)?	Was the anode replaced (yes/no)?	Name of the qualified contractor

Next scheduled sacrificial anode review date	Completed (yes/no)?	Was the anode replaced (yes/no)?	Name of the qualified contractor

Deutschland

STIEBEL ELTRON GmbH & Co. KG
Dr.-Stiebel-Straße 33 | 37603 Holzminden
Tel. 05531 702-0 | Fax 05531 702-480
info@stiebel-eltron.de
www.stiebel-eltron.de

Verkauf

Tel. 05531 702-110 | Fax 05531 702-95108 | info-center@stiebel-eltron.de

Kundendienst

Tel. 05531 702-111 | Fax 05531 702-95890 | kundendienst@stiebel-eltron.de

Ersatzteilverkauf

Tel. 05531 702-120 | Fax 05531 702-95335 | ersatzteile@stiebel-eltron.de

Australia

STIEBEL ELTRON Australia Pty. Ltd.
6 Prohasky Street | Port Melbourne VIC 3207
Tel. 03 9645-1833 | Fax 03 9645-4366
info@stiebel.com.au
www.stiebel.com.au

Austria

STIEBEL ELTRON Ges.m.b.H.
Eferdinger Str. 73 | 4600 Wels
Tel. 07242 47367-0 | Fax 07242 47367-42
info@stiebel-eltron.at
www.stiebel-eltron.at

Belgium

STIEBEL ELTRON bvba/sprl
't Hofveld 6 - D1 | 1702 Groot-Bijgaarden
Tel. 02 42322-22 | Fax 02 42322-12
info@stiebel-eltron.be
www.stiebel-eltron.be

China

STIEBEL ELTRON (Guangzhou) Electric Appliance Co., Ltd.
Rm 102, F1, Yingbin-Yihao Mansion, No. 1 Yingbin Road
Panyu District | 511431 Guangzhou
Tel. 020 39162209 | Fax 020 39162203
info@stiebel-eltron.cn
www.stiebel-eltron.cn

Czech Republic

STIEBEL ELTRON spol. s r.o.
K Hájiřm 946 | 155 00 Praha 5 - Stodůlky
Tel. 251116-111 | Fax 235512-122
info@stiebel-eltron.cz
www.stiebel-eltron.cz

Denmark

Pettinaroli A/S
Mandal Allé 21 | 5500 Middelfart
Tel. 06341 666-6 | Fax 06341 666-0
info@stiebel-eltron.dk
www.stiebel-eltron.dk

Finland

STIEBEL ELTRON OY
Kapinakuja 1 | 04600 Mäntsälä
Tel. 020 720-9988
info@stiebel-eltron.fi
www.stiebel-eltron.fi

France

STIEBEL ELTRON SAS
7-9, rue des Selliers
B.P 85107 | 57073 Metz-Cédex 3
Tel. 0387 7438-88 | Fax 0387 7468-26
info@stiebel-eltron.fr
www.stiebel-eltron.fr

Hungary

STIEBEL ELTRON Kft.
Gyár u. 2 | 2040 Budaörs
Tel. 01 250-6055 | Fax 01 368-8097
info@stiebel-eltron.hu
www.stiebel-eltron.hu

Japan

NIHON STIEBEL Co. Ltd.
Kowa Kawasaki Nishiguchi Building 8F
66-2 Horikawa-Cho
Saiwai-Ku | 212-0013 Kawasaki
Tel. 044 540-3200 | Fax 044 540-3210
info@nihonstiebel.co.jp
www.nihonstiebel.co.jp

Netherlands

STIEBEL ELTRON Nederland B.V.
Daviottenweg 36 | 5222 BH 's-Hertogenbosch
Tel. 073 623-0000 | Fax 073 623-1141
info@stiebel-eltron.nl
www.stiebel-eltron.nl

Poland

STIEBEL ELTRON Polska Sp. z O.O.
ul. Działkowa 2 | 02-234 Warszawa
Tel. 022 60920-30 | Fax 022 60920-29
biuro@stiebel-eltron.pl
www.stiebel-eltron.pl

Russia

STIEBEL ELTRON LLC RUSSIA
Urzhumskaya street 4,
building 2 | 129343 Moscow
Tel. 0495 7753889 | Fax 0495 7753887
info@stiebel-eltron.ru
www.stiebel-eltron.ru

Slovakia

TATRAMAT - ohrievače vody s.r.o.
Hlavná 1 | 058 01 Poprad
Tel. 052 7127-125 | Fax 052 7127-148
info@stiebel-eltron.sk
www.stiebel-eltron.sk

Switzerland

STIEBEL ELTRON AG
Industrie West
Gass 8 | 5242 Lupfig
Tel. 056 4640-500 | Fax 056 4640-501
info@stiebel-eltron.ch
www.stiebel-eltron.ch

Thailand

STIEBEL ELTRON Asia Ltd.
469 Moo 2 Tambol Klong-Jik
Amphur Bangpa-In | 13160 Ayutthaya
Tel. 035 220088 | Fax 035 221188
info@stiebel-eltronasia.com
www.stiebel-eltronasia.com

United Kingdom and Ireland

STIEBEL ELTRON UK Ltd.
Unit 12 Stadium Court
Stadium Road | CH62 3RP Bromborough
Tel. 0151 346-2300 | Fax 0151 334-2913
info@stiebel-eltron.co.uk
www.stiebel-eltron.co.uk

United States of America

STIEBEL ELTRON, Inc.
17 West Street | 01088 West Hatfield MA
Tel. 0413 247-3380 | Fax 0413 247-3369
info@stiebel-eltron-usa.com
www.stiebel-eltron-usa.com

STIEBEL ELTRON



Irrtum und technische Änderungen vorbehalten! | Subject to errors and technical changes! | Sous réserve d'erreurs et de modifications techniques! | Onder voorbehoud van vergissingen en technische wijzigingen! | Salvo error o modificación técnica! | Excepto erro ou alteração técnica | Zastrzeżone zmiany techniczne i ewentualne błędy | Omyly a technické změny jsou vyhrazeny! | A muszaki változtatások és tévedések jogát fenntartjuk! | Отсутствие ошибок не гарантируется. Возможны технические изменения. | Chyby a technické zmeny sú vyhradené! | Stand 9030