

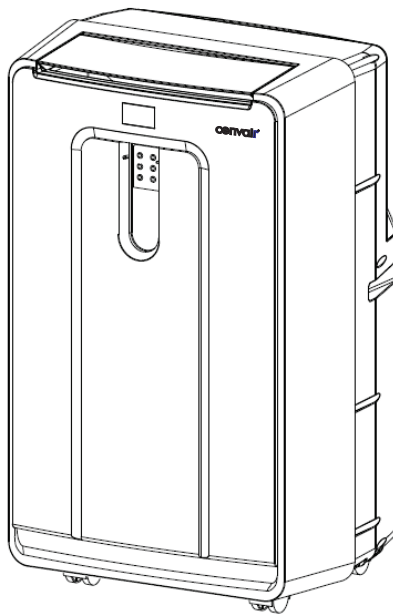

OWNER'S MANUAL

Portable Refrigerated Air Conditioner



CP12CS1

(English) (CP12CS1)



CONTENTS

Introduction	1
Safety	2
Component location.....	3
Installing the exhaust hose	4
Control panel	5
Remote control	6
Operation.....	7-8
Maintenance	9
Troubleshooting	10
Specifications.....	11
Warranty	12

Please read these instructions prior to using the appliance and save them for future reference.



Waste electrical products must not be disposed of with household waste. This product should be taken to your local recycling centre for safe treatment.

INTRODUCTION

THANK YOU for choosing a Convair Air Conditioner. This appliance has been carefully engineered to bring you trouble-free personal air conditioning. Please read this manual carefully so that you take full advantage of the many benefits your Convair provides.

This appliance is not intended for use by persons (including children) with reduced physical, sensory or mental capabilities, or lack of experience and knowledge, unless they have been given supervision or instruction in using the appliance by a person responsible for their safety.

Children should be supervised to ensure that they do not play with the appliance. Do not place anything through the ventilating slots.

Be sure the appliance has been securely and correctly installed according to the installation instructions contained within this manual.

Personal Cooling

Your Convair cooler is a portable air conditioning unit that supplies refrigerated air to a personal area within a room. It is not intended to function as a house or room air conditioner.

Energy Saving Tips

- * Do not locate the air conditioner where furniture or other objects can obstruct the air flow.
- * Keep curtains and blinds closed during the hottest part of the day.
- * Keep the filters clean.
- * Set the air conditioner to maximum cooling and high fan speed initially, then adjust to a comfortable setting.
- * Do not wait until the room is excessively hot before using the air conditioner.

Warranty

Convair air conditioners are warranted against faulty manufacture for 2 years after purchase. Please refer to page 12 for more details on warranty.

SAFETY

For indoor use only.

Transport the air conditioner in an upright position only, or leave it in an upright position for at least 2 hours before use (Fig 1).

Use only in the upright position on a flat level surface and at least 50cm from any objects.

Do not place objects on the air conditioner, or through the ventilating slots or restrict the air inlets & outlets (Fig 2).

Closely supervise any children and pets when the air conditioner is in use.

Do not store or operate the appliance near any flammable substances.

During operation, water will collect in the bottom tank of the air conditioner. Be careful when moving the unit to prevent water from spilling.

Electrical Safety

Ensure the appliance has been installed in accordance with national wiring regulations.

Electrical Safety (cont)

Caution! before connecting the electrical power cord to a power outlet, check that the air conditioner voltage is the same as your power supply (refer to the rating label located on the side of the unit - refer Fig 4). Ensure the power supply is correctly earthed and rated.

Plug the air conditioner directly into a properly installed power outlet. Never use an extension cord, double adaptor or multi power outlet board to run this air conditioner.

Do not pull the unit along by the power cord or place the power cord near a source of heat. Always unroll the power cord completely before use.

If the power supply cord is damaged it must be replaced by the manufacturer, a service agent or similarly qualified persons in order to avoid a hazard.

Switch off and unplug when not in use.

Do not use in humid environments such as bathrooms, laundries or other steamy or wet areas.

Do not touch or operate the air conditioner with wet or damp hands or when standing barefoot.



COMPONENT LOCATION

3

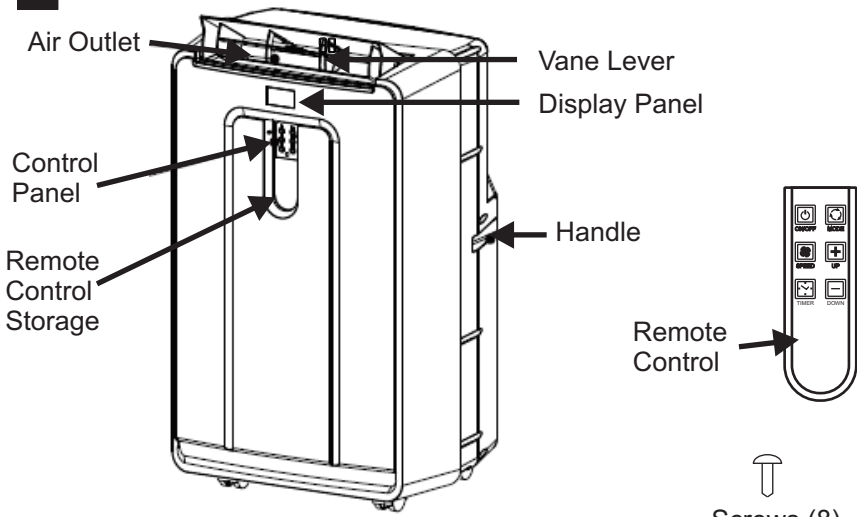

4

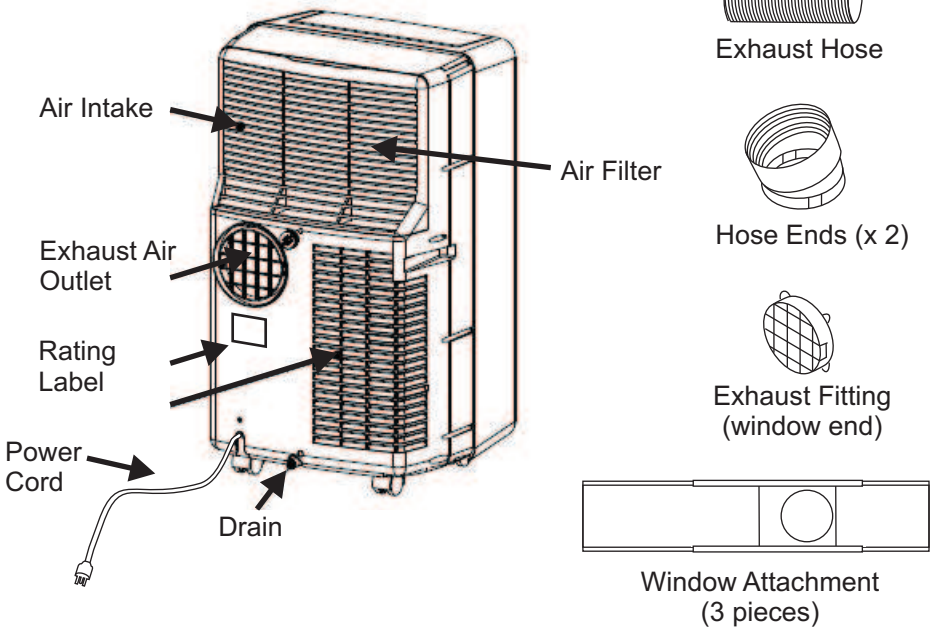

INSTALLING THE EXHAUST HOSE

Step 1: Fit the exhaust hose to the hose ends as shown in a clockwise direction. Push the hose end onto the cooler, and rotate so the slot locks onto the catch (Fig 5A).

Step 2: Screw the round window adaptor into position on the window attachment with the screws (4) provided (Fig 5B).

Step 3: Open the window and fit the adjustable window attachment. Extend the attachment as required and lock into place with the screws (4) provided. Ensure the outlet is not obscured. The window attachment can be installed horizontally or vertically, to suit your window type. Fit the hose end to the window attachment, and lock into place as before (Fig 5B).

Note! The minimum distance required from the operating air conditioner to any obstructing objects or walls is 50cm (Fig 6).

Keep the exhaust hose as short and straight as possible and minimise kinks. This will maximise the cooling performance.

Don't use extension pieces for the exhaust pipe as this will reduce the cooling performance and possibly result in damage to the air conditioner.

Hot air and possibly mist will be emitted from the exhaust hose.

Note! It is critical to the cooler's performance that the hot exhaust air is completely removed from the space being cooled.

5A

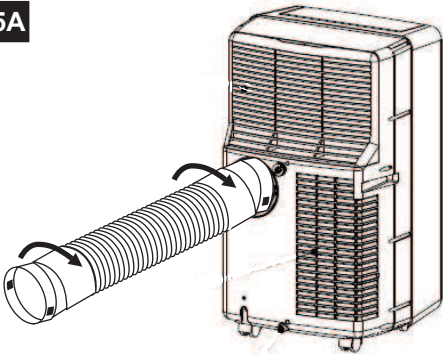

5B

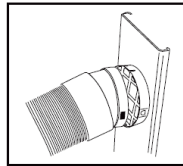

6

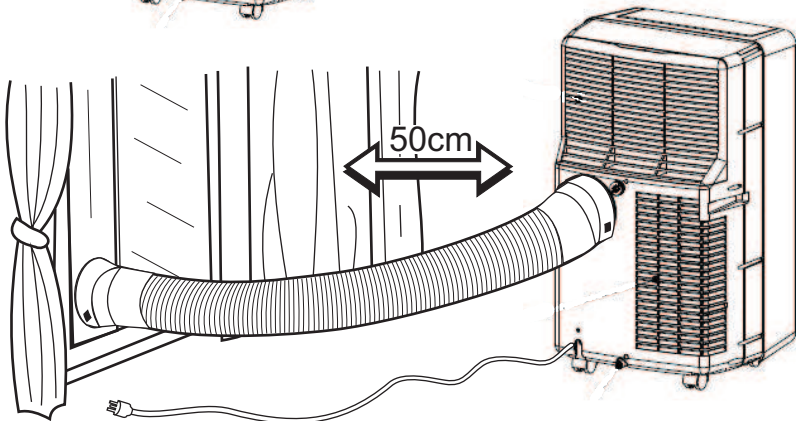

CONTROL PANEL

The control panel is located behind the remote control storage receptacle.
remove the remote control to access the control panel.

7

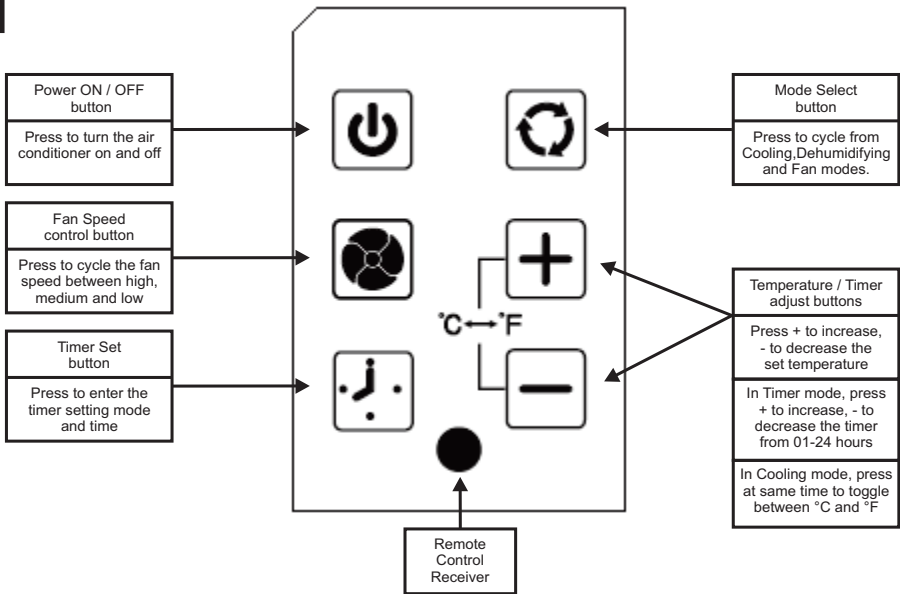

⚠ **NOTE!** To avoid damage to the control panel, do not operate with sharp objects.

DISPLAY PANEL

8

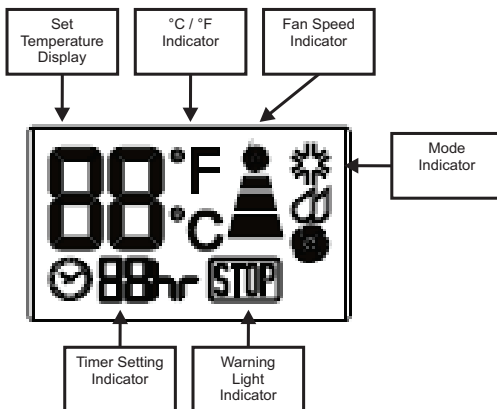

REMOTE CONTROL

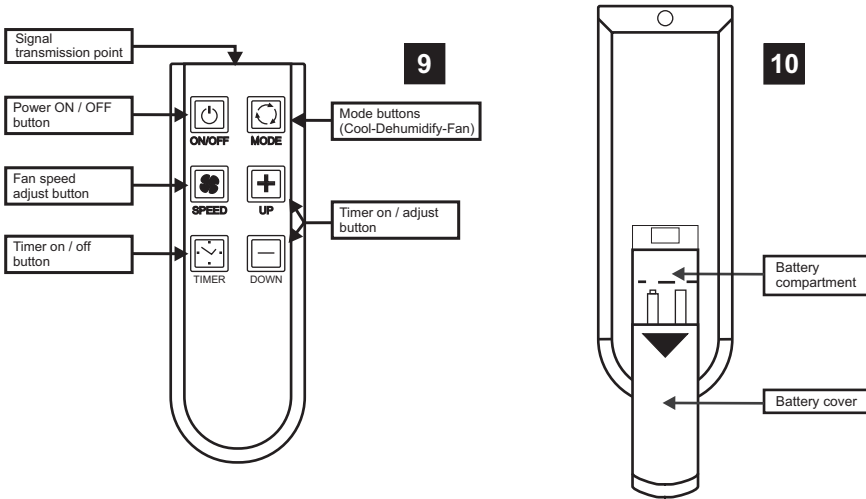

Preparation before operation

Remove the battery cover and insert new batteries (AAA), making sure the + and - match the compartment markings (Fig 10).

During Operation

If the remote control will not operate the air conditioner, the batteries may need to be replaced.

Remove the batteries and replace with new ones. If this does not solve the problem contact your nearest service centre for advice.

Note! The air conditioner must be plugged in and switched on for the remote control to operate the air conditioner. To use, point at the signal receiving window on the front panel and press the remote button. The air conditioner will “beep” when a signal has been received. If there is no beep, press the remote button again, ensuring it is within range (6 metres) of the air conditioner.



NOTE:
WASTE BATTERIES SHOULD
BE DISPOSED OF CORRECTLY

If there are two of the same air conditioners installed, they cannot be controlled separately. When you operate either remote, it will turn on both air conditioners if they are both within signal range (6 metres).

Care of your remote control

Don't let the remote control drop onto hard surfaces or be subjected to sudden shocks in any way. The warranty does not cover misuse or accidental damage.

Don't place the remote control in direct sunlight, or near extremes of temperature. This will affect the control's temperature reading.

Don't allow the remote control to get wet.

Don't place near strong electromagnetic waves.

Don't mix old and new batteries!
If the remote control will not be used for a long time, remove the batteries to avoid corrosion.

OPERATION



Starting the air conditioner

Step 1: Ensure the cooler is plugged in and switched on.

Step 2: Lift up the air outlet vent ready for use.

Step 3: Press the ON/OFF button  on the remote control or ON/OFF button on the control panel to start the air conditioner.

Step 4: Press the MODE button  on the control panel or remote control to select the desired operating mode (Fig 7, 8 & 11):

-  **Cooling mode** - refrigerated cooling
-  **Dehumidifying mode** - for extracting moisture from the air
-  **Fan mode** - Fan only operation (no cooling)

Step 5: Press “+” or “-” buttons on the control panel or on the remote control to select the desired operating ‘set’ temperature.

The set temperature range is 16°C-32°C
In Cooling mode, cooling will occur if the set temperature is less than the room temperature.

Tip! Do not set the cooling temperature too low. This will consume more power. 24°C is the recommended set temperature, with high fan speed.

Note! Changing the set temperature will have no effect in DEHUMIDIFYING or FAN modes.

Note! The display can toggle between °C and °F by pressing both the “+” and “-” buttons on the control panel together and holding for 2 seconds.

Step 6: Press the FAN SPEED button  on the control panel or remote control to adjust the fan speed. Each press will cycle the fan speed between high, medium and low.

Note! In Cooling mode, the fan will continue to run even when the compressor has cycled off.

Step 7: The air conditioner is fitted with horizontal air direction vanes. Carefully move the vanes to the desired position by hand (Fig 12).

Important! During cooling mode, water will collect in the air conditioner’s tank. This water is recirculated and some will be exhausted out with the hot air, but will slowly fill up the tank. This occurs more quickly in humid conditions. If the tank should fill, the ‘water full’ indicator will be lit on the control display and the unit will shut down. The cooler cannot be restarted until the water tank is drained. Refer to the Maintenance section for draining the tank should this occur.

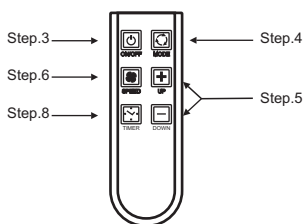

11

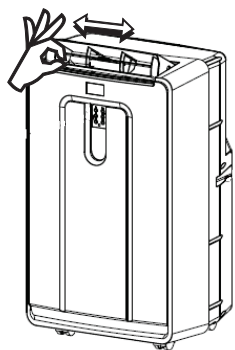

12

OPERATION cont.

Timer Function

The air conditioner is fitted with a timer function. This can be set up to 24 hours in advance. To use this function, the cooler must be plugged in and ready to operate.

Step 8: Setting the timer

With the air conditioner ON, press the TIMER button on the remote control or control panel to set the number of hours before the air conditioner powers off. The control panel display will flash and show the time setting. Press the "+" or "-" buttons to increase or decrease the time in 1 hour increments from 1 - 24 hrs. After 5 seconds the display will stop flashing and the TIMER symbol will be lit on the display panel (Fig 8).

When the air conditioner is OFF (but still plugged in), repeat the above to set the number of hours before the cooler powers ON. The air conditioner will start up with the last settings used.

Note! When the air conditioner is working, only the TIMER OFF can be set. When the air conditioner is off, only the TIMER ON can be set.

How to cancel the timer

To cancel the timer, simply press the TIMER button again. The TIMER indicator will stop glowing.

MAINTENANCE

Always disconnect the air conditioner from the electricity mains before cleaning or draining.

To maximize the efficiency of the air conditioner, clean regularly.

Cleaning the housing

Use a soft, damp cloth to wipe the body clean.

Never use aggressive chemicals, spirits, detergents, chemically treated cloths, or other cleansing solutions. These substances could possibly damage the cabinet.

Cleaning the filters

Remove the filter from the top air inlet vent as shown (Fig 13A).

Use a vacuum cleaner or tap the filter lightly to remove loose dust and dirt and then rinse under running water (no hotter than 40°C).

Dry thoroughly before replacing.

Take care to replace the filter back into the slot in the cooler.

Note! Never operate the air conditioner without the filter.

Draining the Air Conditioner

To drain the air conditioner, place it over a drain point before unscrewing the cap and removing the drain plug, as water will flow out as soon as the plug is removed.

Remove the plug at the bottom rear of the appliance and allow the tank to completely drain (Fig 13B).

Note! Always replace the drain plug immediately after draining.

End of season storage:

- Drain any water from the unit.
- Operate the unit in fan only mode for a few hours, to thoroughly dry the inside.
- Clean or change the filter.
- Unplug and carefully store the power cord and plug end.
- Replace in the original carton or cover for storage.

13 A

Remove filter from the air conditioner and clean every 2 weeks.

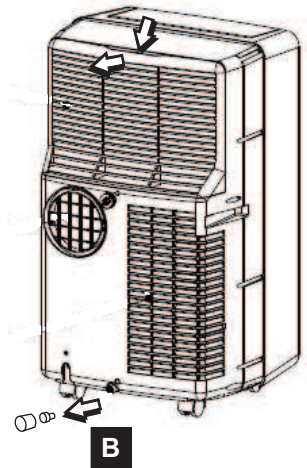

TROUBLESHOOTING

Problem	Check
The air conditioner does not run.	Is the air conditioner plugged in?
	Is there a power failure?
	Is the "WATER FULL" error code flashing? Drain the tank as shown (Fig 13).
	Is the room temperature below the set temperature?
The air conditioner has little effect (firstly ensure that the room being cooled is not too large for the stated capacity of the air conditioner).	Is there direct sunshine? Remember to close curtains or blinds.
	Are windows or doors open?
	More people in the room will generate more heat.
	Is there something in the room producing excessive heat?
	Is the exhaust fitted correctly or obstructed? All exhaust air needs to be completely removed from the room.
The air conditioner is not as cool as it once was.	Are the filters dusty or dirty, restricting the airflow?
	Is the air inlet or outlet blocked?
	Is the room temperature below the set temperature?
The air conditioner is too noisy.	Is the air conditioner positioned unevenly, so as to create vibration?
	Is the floor beneath the air conditioner uneven?
The compressor will not run.	<p>It is possible that the overheat protection for the compressor is on. Wait for it to reset.</p> <p>Note: when changing between different modes (cooling to fan or dehumidifying mode etc) the compressor will turn off. A 3 minute delay will occur before the compressor will turn on again.</p>



Never try to dismantle the air conditioner yourself.

In case of problems that cannot be fixed by using the above guide, or if service on your air conditioner is required, please contact your dealer or designated service agent.

SPECIFICATIONS

SEELEY INTERNATIONAL - CONVAIR PORTABLE AIR CONDITIONER	
Model(s)	CP12CS1
Function	Personal Cooling
Cooling Capacity (Watts) †	3500 (12,000 Btu/hr)
Air Flow Volume (m ³ / hr)	300
Power Supply	220-240V ~ 50Hz
Rated Input Power (Watts)	1100
Fuse Type	3.15A / 250V
Refrigerant Type / Charge (kg)	R410A / 0.6
High Side Pressure - Maximum (MPa)	3.53
Low Side Pressure - Maximum (MPa)	1.77
Water Ingress Protection Rating	IPX0
Weight (kg)	32
Dimensions (mm) (width / depth / height)	450 / 390 / 745

† Based on manufacturer's test results using the Air Enthalpy method

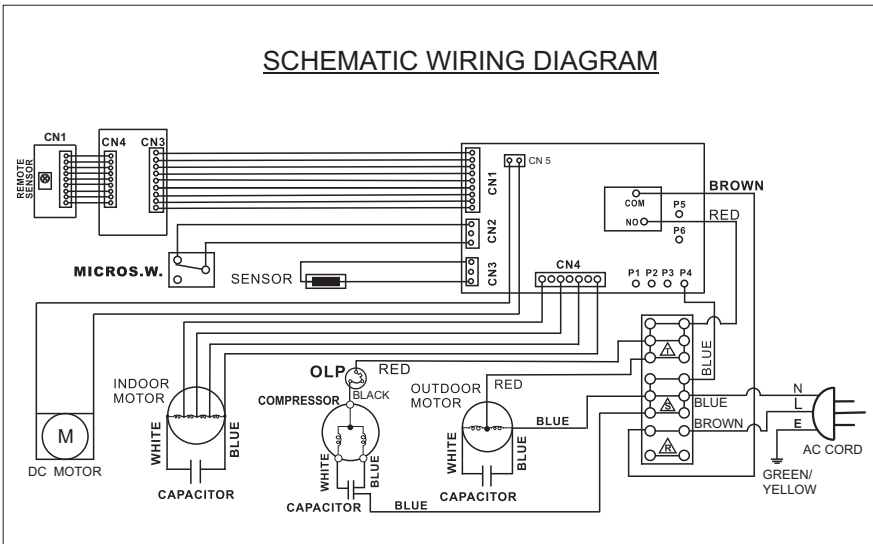

As a policy of continual product improvement, this manual, its contents and specifications are subject to change without notice.

WARRANTY

In this warranty:

We or us means Seeley International Pty Ltd ABN 23 054 687 035, and our contact details are set out at the end of this warranty;

You means you, the original end-user purchaser of the Goods;

Supplier means the authorised distributor or retailer of the Goods that sold you the Goods in Australia; and

Goods means the product, unit, appliance or equipment which was accompanied by this warranty and purchased in Australia.

Our Goods come with guarantees that cannot be excluded under the Australian Consumer Law. You are entitled to a replacement or refund for a major failure and for compensation for any other reasonably foreseeable loss or damage. You are also entitled to have the Goods repaired or replaced if the Goods fail to be of acceptable quality and the failure does not amount to a major failure.

In addition to any rights and remedies that You may have under the Australian Consumer Law or any other law, subject to the terms of this warranty, We provide the following warranty:

1. If, during the first 24 months from the date of first retail purchase (**Warranty Period**), the Goods upon examination prove defective by reason of improper workmanship or material, We will repair at our nearest service centre or replace (at our option), the product or any part thereof without charge. Should we deem in our absolute discretion to replace the Goods, we may substitute any similar good even if it is not on our current price/equipment list. Further, Goods presented for repair may be replaced by refurbished goods of the same type rather than being repaired. Refurbished parts may be used to repair the Goods.
2. We are under no obligation to repair or replace the Goods under clause 1 if the Goods have not been used only for personal, domestic or household purposes or have not been operated and maintained in accordance with the instructions in the Owner's Manual. The addition of any third party device or the removal or the alteration of any of our components will void this warranty. In addition, the warranty granted under clause 1 does not apply to:
 - Consumable components such as filters,
 - Adjustments necessary due to misuse of the cooler,
 - Normal user maintenance,
 - Setting of controls,
 - Transit damage, or
 - Damage caused by user misuse, tampering, or failure to observe the care and special provisions in the instructions.
3. The warranty granted under clause 1 is limited to repair or replacement only. As far as the law permits, We will not be liable for any consequential loss suffered through, or resulting from, the non operation, or ineffective operation of the Goods. The warranty granted under clause 1 does not cover damage to the Goods or other loss resulting from acts of God.
4. We are not responsible in any way for any failure and/or inadequate performance of the Goods which arises from or is connected to the use in the Goods of non-genuine spare parts. We strongly recommend that only spare parts supplied or approved by us are used in the Goods.
5. No other person, firm or corporation is authorised by us to offer or give on our behalf any other or greater warranty than that given under this warranty. The benefits conferred by this warranty are in favour of You and any person deriving title to the Goods through or under such person and are intended to be separate from and additional to all other rights and remedies that they may have in law in respect of the Goods.
6. If it is less than fifteen (15) days from the date of purchase of the Goods, in order to claim under the warranty granted under clause 1 You must return the Goods to the Supplier at the place of purchase together with the proof of purchase. It is your responsibility to cover all costs of returning the Goods to the Supplier at the place of purchase.

WARRANTY cont.

7. If it is more than fifteen (15) days after the date of purchase, in order to claim under the warranty granted under clause 1 You must:
- (a) either:
 - (i) contact us within the Warranty Period on: 1300 526 410;
 - or
 - (ii) log a claim on our website www.seeleyinternational.com within the Warranty Period;
 - and
 - (b) return the Goods to your nearest service centre (or to us at the address below) by prepaid freight within the Warranty Period, together with (i) the legible and unmodified proof of purchase, which clearly indicates the name and address of the original retailer, the date and place of purchase, the product name or other product serial number, and (ii) a copy of the completed Warranty Information below. (If you choose to return the Goods to us, there is an additional requirement - they will also need to be accompanied by a covering letter which states your name and address and daytime telephone number, and the model and serial number of the goods.)
8. This warranty does not cover the cost of claiming under the warranty, it is your responsibility to cover all forwarding and return freight costs incurred in sending the Goods to and from your nearest service centre or us.
9. This warranty is only valid and enforceable in Australia.

Our liability under this warranty is limited to the extent permitted by law. That is, to the extent that it is fair and reasonable, if the Goods are not of a kind ordinarily acquired for personal, domestic or household use or consumption, your remedies associated with any failure or defect of the Product will be limited to:

- (a) the replacement of the Goods or the supply of equivalent goods;
- (b) the repair of the Goods;
- (c) the payment of the cost of replacing the Goods or of acquiring equivalent goods; or
- (d) the payment of the cost of having the Goods repaired

and subject to the terms and conditions included in this warranty.

To ensure that service either pursuant to the above warranty or otherwise is readily available, we have established in all States authorised service centres, which are available to deal with service requirements.

For further information about your nearest service centre and other enquiries please call our Service Centre on:

1300 526 410

Please retain your receipt as proof of purchase. Every request for warranty must be accompanied by proof of purchase.

Complete the following for your records:

Serial Number:

Product: *Convair SUPERCOOL*

Model: CP12CS1

Purchased from:

.....

Date purchased: /...../.....

Service Department
Seeley International Pty Ltd
112 O'Sullivan Beach Road, Lonsdale, South Australia 5160
Customer service centre in Australia: 1300 526 410
Website: www.seeleyinternational.com

It is the policy of Seeley International to introduce continual product improvement. Accordingly, specifications are subject to change without notice. Please consult with your dealer to confirm the specifications of the model selected.



Warranty Service

Australia 1-300-526-410
seeleyinternational.com

convair®