

Redsbaby® Bounce (2016 Model)
Instruction Manual

Contents

General instructions	3
Warranty information	4
Warnings and safety precautions	6
Features and components	8
Assembly instructions	9
Frame	9
Brake component	9
Rear wheels	10
Front swivel wheels	10
Bassinet and bumper	10
Removing the bassinet and bumper	11
Seat and bumper	11
Basket	12
Using your Redsbaby Bounce	13
Folding and unfolding	13
Engaging and releasing the brake	14
Locking the front swivel wheels	14
Adjusting the handle	14
Using the 5-point safety harness	15
Reversing and reclining the seat	16
Reversing the bassinet	16
Using the tether strap	16
Lifting and carrying your Redsbaby Bounce safely	16
Accessories – Assembly and Use	17
Rain cover	17
Bounce Canopy	17
Bassinet apron	17
Noslip™ Contoured Seat Liner	18
Maxi-Cosi Capsule Adaptors - Travel System	19
Product Care	21

General Instructions

This document contains important information and must be kept for future reference.

Please read thoroughly before commencing assembly and use of your Redsbaby Bounce. Incorrect assembly and use can be dangerous and result in serious injury or even death.

There may be slight variations in the design of your product to that shown in the images of this instruction manual.

Warranty information

12 Month Warranty

The Redsbaby Bounce and its accessories come with a 12 Month Warranty to cover against faults in materials and workmanship when your products are used under normal conditions, according to our user manuals and technical specifications.

Our goods come with guarantees that cannot be excluded under the Australian Consumer Law. You are entitled to a replacement or refund for a major failure and compensation for any other reasonably foreseeable loss or damage. You are also entitled to have the goods repaired or replaced if the goods fail to be of acceptable quality and the failure does not amount to a major failure.

The 12 Month Warranty period starts from the date your product(s) are dispatched from our warehouse. This includes products that are purchased via pre-sale (for example items that are out of stock or newly launching products). Please remember that for a claim to be valid, it must be made within the claims period.

There are a few circumstances under which the warranty is not valid including:

- defects resulting from improper care or use;
- normal wear and tear, including scratches to the stroller frame;
- products that are purchased second hand or from an unauthorised distributor;
- faulty or incorrect assembly;
- using a part or accessory that is not compatible with the product and/or not manufactured by Redsbaby;
- tyre punctures; and
- damage to handlebar grips or fabrics as a result of normal handling and daily use.

For a full list of what is covered and what is excluded from the warranty, please read our Terms and Conditions at www.redsbaby.com.au. Please

ensure you follow the assembly instructions, which can be found in this instruction manual.

How To Make A Warranty Claim

Send an email to info@redsbaby.com.au to notify us of your warranty claim. To validate your warranty claim we will require you to include in your email:

- a description of the warranty defect including photographs;
- your contact details;
- attached invoice with order number; and
- product batch number (the batch number is printed on a sticker that is located on the crossbar above the shopping basket on the stroller frame).

We will respond to your warranty claim within 7 business days and depending on the nature of the warranty claim, arrange collection of the product from your nominated address. Collection will take place on a business day (i.e. not a public holiday or weekend within your state or territory) between 7am and 5.30pm. Please take care to repack the product in secure and stable packaging to avoid any damage occurring in the returns transit. We do not take responsibility for any damage that occurs in transit to and from our pram repairer.

Once our pram repairer has received the product they will inspect and confirm the reported defect. We will then contact you with further information surrounding the repair such as the estimated turn around time.

If you have any questions, you can contact us at info@redsbaby.com.au.

Warnings and safety precautions

Please read the following warnings and safety precautions thoroughly before using your Redsbaby Bounce. Incorrect assembly and use can result in serious injury or death.

Always follow safety instructions for assembly, folding and use.

Always ensure that your Redsbaby Bounce is correctly assembled and locks are engaged before use.

After unpacking, immediately discard any plastic wrapping and packaging materials, as these can lead to a choking hazard.

Always use the safety features that come with your Redsbaby Bounce, such as the tether strap, brakes and harness.



GENERAL WARNINGS:

- To avoid injury or death: Always apply the brakes whenever the Redsbaby Bounce is stationary.
- Do not leave children unattended.
- Secure the child in the harness at all times.
- Do not carry extra children or bags on the Redsbaby Bounce.
- Make sure children are clear of any moving parts if you adjust the Redsbaby Bounce, otherwise they may be injured.
- Follow the manufacturer's instructions.
- Put on all the brakes whenever you park the Redsbaby Bounce.
- Use the harness at all times.
- When not in use disconnect shoulder straps from the waist strap and/or buckle.
- The harness can form loops which may cause a strangulation hazard. Never leave a harness connected when not fitted to a child in the Redsbaby Bounce.
- Use the tether strap to stop the Redsbaby Bounce rolling away.
- Do not use the seat or bassinet with any other models of stroller.
- Do not use bassinet once the child can sit up unaided.
- Only use the bassinet in the flat position. Do not recline.
- Do not use any accessories that are not designed for or compatible

with the Redsbaby Bounce.

- Take care when used on stairs or escalators.
- Do not use or leave the Redsbaby Bounce near open fire or exposed flame.
- Brakes must always be applied when the Redsbaby Bounce is not moving.



GENERAL SAFETY PRECAUTIONS:

- When the vehicle is being folded and unfolded, there is potential for fingers or parts of the body to be injured and due care should be exercised.
- Overloading, incorrect folding or the use of non-approved accessories may cause injury or damage your Redsbaby Bounce.
- Ensure you follow the regular maintenance and care instructions included in this manual. Pay special attention to maintenance and care of the brakes.
- The Redsbaby Bounce must only be used for one (1) child.
- Do not hang bags on Redsbaby Bounce handles, as this can cause it to become unstable.
- Do not lift or carry the Redsbaby Bounce when a child is in it.
- Do not lift or carry the Redsbaby Bounce when fully assembled. Only lift and carry when folded.
- The Redsbaby Bounce is designed for use on flat or gentle sloping surfaces and may be unstable on higher sloping and uneven surfaces. The vehicle may tip over when used incorrectly on steep inclines/declines.
- Do not leave the rain cover on without the ventilation window on the front of the rain cover open.
- When using your Redsbaby Bounce on stairs or escalators, take care.



MAXIMUM WEIGHT LIMITS:

- Maximum weight for a child in the bassinet is 9kg (19.8 lbs).
- Maximum weight for a child in the seat is 17kg (37.5 lbs).
- Maximum weight for items in the pockets on the back of the seat is 1kg (2.2 lbs).
- Maximum weight for items in the basket is 5kg (11 lbs).

Features and components

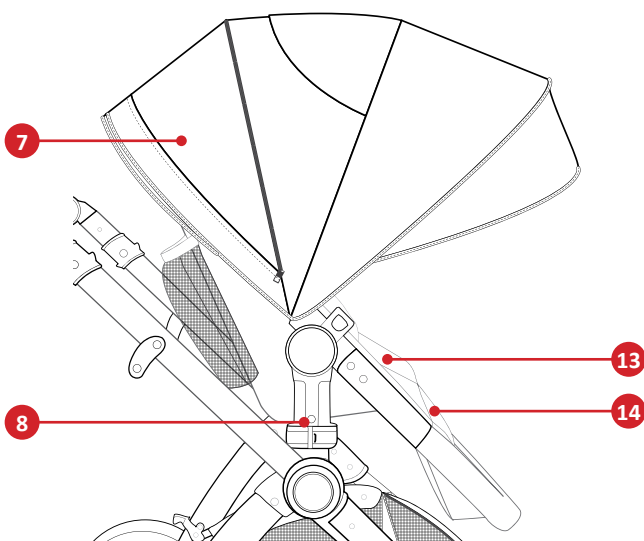
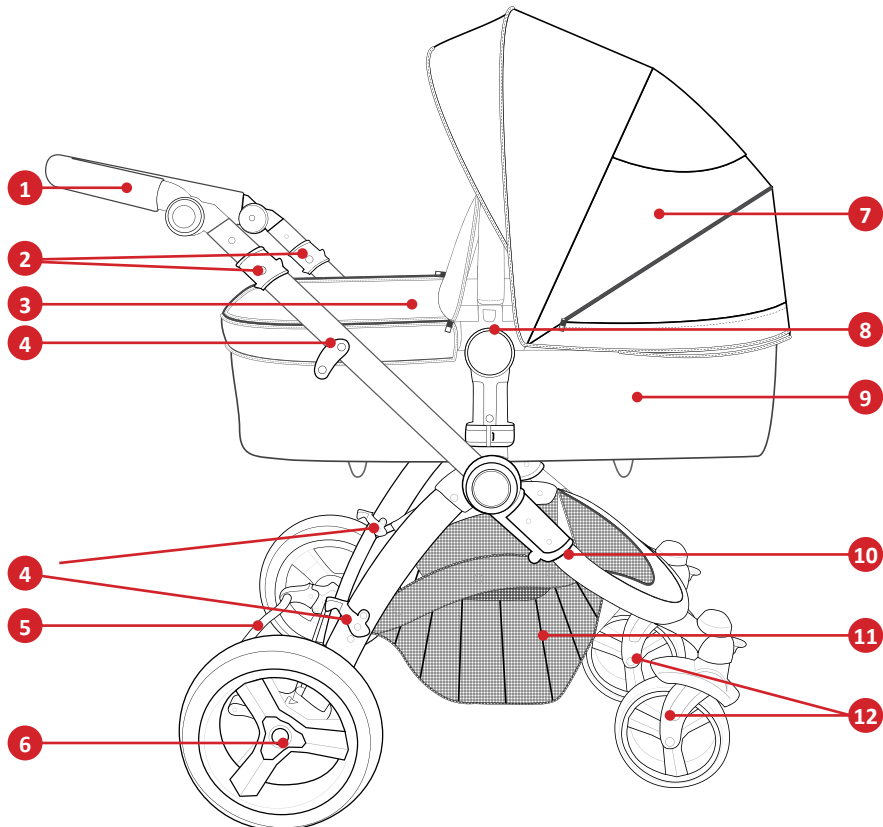

- | | |
|-----------------------|----------------------------|
| 1. Handle | 9. Bassinet |
| 2. Fold locks | 10. Frame |
| 3. Bassinet apron | 11. Basket |
| 4. Frame fold latches | 12. Front swivel wheels |
| 5. Brake | 13. 5-point safety harness |
| 6. Rear wheels | 14. Seat with seat liner |
| 7. Canopy | |
| 8. Circular frame | |

Assembly instructions

Frame

To release the frame from the folded position:

1. Place frame on the ground and position yourself behind the handle bar.
2. Pull back on the two frame fold latches located on either side of the frame simultaneously.
3. Holding the frame on either side of the disengaged frame fold latches, gently lift the frame continuing until the frame locks into place. When the frame has been fully opened, you will hear and feel a firm 'click'.



Brake component

Align the brake component with the two rear ends of the pram. Click the brake component into place. Ensure that the brake component is assembled correctly by checking the two silver locking pins located on the underside of the rear brake component are in place.



Rear wheels

Fit the rear wheels on the axle housings located on either side of the rear brake component. You will hear and feel a firm 'click' when the wheels are locked in place.

IMPORTANT: Ensure you check that the wheels are clicked in correctly by tugging them outwards. Failure to attach the wheels correctly will result in them falling off the pram while in use.

To remove, simply press the button in the middle of the wheel to release.

Front swivel wheels

Fit the front swivel wheels by inserting them into the front wheel locks located at the front of the frame. You will hear and feel a firm 'click' when the wheels are locked in place.

Assembling the bassinet and bumper



WARNING:

- Do not use bassinet once the child can sit up unaided.
- This bassinet is only approved for use with model Redsbaby Bounce.
- The maximum weight of a child that can be carried in this bassinet: 9kgs.
- Only use the bassinet in the flat position. Do not recline.

1. Secure the Velcro tabs on the bassinet lining around the circular frame. Ensure the end of the lining which has the warning label is secured around the end of the circular frame which has the two plastic clasps that the canopy clips into.

IMPORTANT: Ensure each velcro tab is secured as tightly as possible.

2. Place the bassinet board in the bottom of the bassinet liner. Secure using the Velcro tabs located at the top and bottom ends of the bassinet liner onto the bassinet board.

3. Place the bassinet mattress on top of the bassinet board.

4. Secure the bassinet apron using the Velcro tabs provided.

5. If desired, attach the bassinet bumper by aligning the ends of the bumper with the two openings on the circular frame. Gently push down into place until you hear and feel a 'click' on both sides. Check the bumper bar is locked securely.

11. If desired, attach the canopy by following the instructions on page 17.
12. To place on the frame, push down gently until you feel and hear a 'click'.

Removing bassinet and bumper

1. Remove the bumper by simultaneously pushing the buttons on either side of the bumper and lifting upwards.
2. Remove the bassinet apron by releasing the Velcro tabs.
3. Remove the bassinet mattress.
4. Remove the bassinet board by releasing the Velcro tabs at the top and bottom ends of the bassinet board and gently lifting out.
5. Release the Velcro tabs on the lining from around the the circular frame.

Assembling the seat and bumper



WARNING:

- Do not use this seat with any other models of stroller.
- This seat is only approved for use with model: Redsbaby Bounce.
- The maximum weight of a child that can be carried in this seat: 17kgs.

1. Take the fabric seat unit and stretch the head rest section over the top of the circular frame.
2. Pull the rest of the seat unit fabric tightly towards the bottom of the frame. Take the safety straps and hook over the side of the frame.
3. Turn the frame over and then clip both ends of the safety strap together. Tighten if necessary.
4. Wrap the foot area around the bottom of the circular frame and secure firmly onto the Velcro strips at the bottom of the seat fabric.
5. Attach the bumper by aligning the ends of the bumper with the two openings on the circular frame. Gently push down into place until you hear and feel a firm 'click' on both sides.
6. If desired, attach the canopy by following the instructions on page 17.
7. To place the seat on the frame, push down gently until you feel and hear a firm 'click'.

Basket

IMPORTANT: Maximum weight for items in the basket is 5kg.

Note: Your Redsbaby Bounce will come with the basket assembled.

To Remove:

1. Unscrew the basket from the pram frame at the front.
2. Release the buttons that secure the basket to the basket rods.

Using your Redsbaby Bounce

Folding and unfolding the Redsbaby Bounce frame



WARNING:

- Make sure children are clear of any moving parts when you adjust the Redsbaby Bounce, otherwise they may be injured.
- Ensure the frame fold locks are engaged correctly before placing a child in the Redsbaby Bounce.

To release the frame from the folded position:

1. Pull back on the two frame fold latches located on either side of the frame simultaneously.
3. Holding the frame on either side of the disengaged frame fold latches, gently lift the frame and place on the ground.
4. Continue to lift the handle until the frame fold locks engage.

IMPORTANT: When the frame fold locks have been engaged correctly and the frame has been fully opened, you will hear and feel a firm 'click'.

To fold the frame

1. Remove the bassinet or seat unit if attached to the frame.
2. Simultaneously pull back on the frame fold locks on the left and right hand side of the frame.
Tip: You can rest the handle bar on your waist to provide some resistance if required.
3. Gently fold the frame downwards until the frame fold latches automatically engage.

Note: The frame fold latches will engage automatically.

Note: If the front swivel wheels become caught, gently toggle to lay sideways.

4. Turn the handle bar inwards by pressing the buttons located on either side simultaneously.

Tip: You can also fold the Redsbaby Bounce with the seat connected in the fully upright and forward-facing position.

Safe lifting and carrying of the Redsbaby Bounce frame when folded

IMPORTANT: Do not lift or carry the Redsbaby Bounce when a child is in it.

IMPORTANT: Do not lift or carry the Redsbaby Bounce when fully assembled. Only lift and carry when folded.

1. Always lift and carry the frame using two hands.
2. Ensure the frame fold latches are engaged.

Engaging and releasing the brake

The brake is located between the rear wheels of the Redsbaby Bounce. The brake bar is identified by two red components on either end.

1. To engage the brake, press down on the brake bar at the rear of the Redsbaby Bounce with your foot until you feel the brake engage.
2. To release the brake, lift the brake bar up with your foot until the brake lock disengages.

Locking the front swivel wheels

1. Press downwards on the tab buttons located at the front of the wheels until you hear and feel a 'click'.
2. Push the Redsbaby Bounce forwards until you hear a second click in both front wheels.
3. To unlock, simply lift the tab buttons upwards. When released successfully, you will hear and feel a 'click'.

Adjusting the handle

Note: Your handle can be adjusted to five height options.

Simultaneously press the buttons located on either side of the handle and move the handle to the desired height.

Using the 5-point safety harness



WARNING:

- Use the harness at all times.
- When not in use disconnect shoulder straps from the waist strap and/or buckle. The harness can form loops which may cause a strangulation hazard. Never leave a harness connected when not fitted to a child in the Redsbaby Bounce.

IMPORTANT: For the safety of your child the 5-point safety harness must be properly fitted and adjusted. Follow the instructions and Figure 1 below.

1. Ensure the seat is assembled correctly by following steps on page 13.
2. Ensure the seat bottom is sitting flat on the seat.
3. Slide the shoulder strap clip (A1) onto the waist strap clip (B1) and clip into the center buckle (C).
4. Slide the shoulder strap clip (A2) onto the waist strap clip (B2) and clip into the center buckle (C)

Note: When your child is smaller, you can feed the shoulder straps through the loops provided on the seat back so that the shoulder straps sit just above the shoulders of your child.



Figure 1

5. Adjust the shoulder strap (A1) and (A2) and waist straps (B1) and (B2) to the desired fit.
6. To unlock the 5-point safety harness, simply press the button in the middle of the centre buckle (C) to release all straps at once.

Note: Padding has been provided for the shoulder straps (A1) and (A2) and crotch strap (D) for the comfort of your child. The use of this padding is optional.

Reversing and reclining the seat

IMPORTANT: Do not reverse or recline the seat when a child is in it.

1. To recline, press and hold both round buttons on the side of the seat and move into the desired position. When in place, you will hear and feel a firm 'click'.

2. To reverse, remove the seat unit by pressing the rectangular release buttons on either side of the seat unit and lift upwards. When the release locks are disengaged, you will hear and feel a firm 'click'. The seat unit can be fitted either rear or forward facing.

Reversing the bassinet

IMPORTANT: Only use the bassinet in the flat position. Do not recline.

To reverse, remove the bassinet by pressing the rectangular release buttons on either side of the bassinet unit. When the release locks are disengaged, you will hear and feel a firm 'click'. The bassinet unit can be fitted either rear or forward facing.

Using the tether strap



WARNING:

- Use the tether strap to stop the Redsbaby Bounce rolling away.

Attach the tether strap to your wrist at all times when using the Redsbaby Bounce.

Lifting and carrying the Redsbaby Bounce safely

IMPORTANT: Do not lift or carry the Redsbaby Bounce when a child is in it.

IMPORTANT: Do not lift or carry the Redsbaby Bounce when fully assembled. Only lift and carry when folded. For folding instructions, refer to page 11.

Accessories



WARNING:

- Do not use any accessories that are not designed for or compatible with the Redsbaby Bounce.

IMPORTANT: The following accessories are only compatible with Redsbaby Bounce. Do not use with any other model of pram/stroller.

Rain Cover (Sold Separately)

IMPORTANT: Do not leave the rain cover on without the ventilation window on the front of the rain cover open.

Note: The canopy must be attached to the Redsbaby Bounce before securing the rain cover.

Starting at the back of the canopy, gently pull the rain cover over the bassinet or seat. Ensure the canopy peak is flipped over in the forward position to ensure correct fitting of the rain cover.

Bounce Canopy

To assemble

1. Pull the canopy over the top of the circle frame and clip the canopy onto both sides of the circle frame above the bumper bar.
2. If using the seat, secure the velcro tabs on the canopy to the velcro tabs on the top of the seat.

Bassinet Apron

Fit the bassinet apron by securing the velcro straps on the bassinet apron to the bassinet liner.

Tip: Folding back the bassinet apron to see your child.

You can unzip either side of the bassinet lining and fold the bassinet apron backwards. This will enable you to see your child without having to remove the whole bassinet apron.

Noslip™ Contoured Seat Liner

Remove the shoulder and crotch padding from the Bounce seat unit harness. Lift the seat unit up and place the elastic strap underneath the seat and flip back out.

Align your seat liner on the Bounce seat unit. Feed the five point safety harness through the respective crotch, waist and shoulder strap holes. If desired, replace the shoulder and crotch padding.

Maxi-Cosi Capsule Adaptors - Travel System

Note: Accessory sold separately

Securing the adaptors to your Redsbaby Bounce chassis

1. Ensure your chassis is assembled correctly by following the instructions in your Redsbaby Bounce Instruction Manual.
2. Stand behind your Redsbaby Bounce handle bar, and click the adaptor marked with the 'R' symbol into the right-hand side, with the 'R' symbol facing outwards. You will hear and feel a firm 'click' when the adaptor is in place.
3. Repeat with the adaptor with the 'L' symbol, clicking it into the left hand side, with the 'L' symbol facing outwards. See Figure 2.



Securing your Maxi Cosi capsule into your Redsbaby Bounce adaptors:

1. Hold the Maxi Cosi capsule facing you, and using both hands push the capsule down onto the adaptors to click into place.
- IMPORTANT:** To check that the capsule has clicked in correctly, lift the handle of the capsule upwards. See Figure 3.



To remove your Maxi Cosi capsule from your Redsbaby Bounce adaptors:

1. Press the left and right release buttons on the Maxi Cosi capsule. Lift upwards. See Figure 4.



To remove your Maxi Cosi adaptors from your Redsbaby Bounce chassis:

1. Press the grey release buttons on each adaptor. When the release locks are disengaged, you will hear and feel a firm 'click' and you can lift them upwards to remove.

Product care

IMPORTANT: Ensure you follow the regular maintenance and care instructions. Pay special attention to maintenance and care of the brakes.

General Maintenance

- Regularly inspect the locking devices, brakes, harness assembly, catches, seat adjusters, joints and fixings to ensure they are secure and in full working order.
- ***Do not store your Redsbaby Bounce in your car boot for prolonged periods of time, especially when it is hot and this can lead to warping some of the plastics parts and reduce the life of your product.***
- The brakes and wheels are subject to wear and should be replaced as and when necessary. Brakes are available through contacting our customer care team at info@redsbaby.com.au.
- Should any parts of the Redsbaby Bounce become stiff or difficult to operate, ensure that dirt is not the cause. Use a light application of a silicone spray lubricant, ensuring the lubricant penetrates between the components. Use sparingly, as excessive application may encourage the accumulation of dirt. Regular light lubrication of moving parts will extend the life of your Redsbaby Bounce and make operating, opening and folding much easier.
- Do not leave the Redsbaby Bounce in sunlight for prolonged periods of time, as the colour of some fabrics may fade.
- Store the Redsbaby Bounce in a dry, well-ventilated and safe place.
- Do not use your Redsbaby Bounce if any screws are loose or missing or if any component is damaged.

Cleaning

Plastic and metal parts

- Sponge clean with warm water and a mild detergent and then air dry.
- Do not use any abrasive or corrosive cleaning products on your Redsbaby Bounce.

Fabrics

- May be cleaned by sponging lightly with warm water and a mild soap (ensure your child is not allergic to the soap you use). Then air dry.
- For more instructions, follow the care labels on each fabric item.

IMPORTANT: Do not place any fabric or other component of your Redsbaby Bounce in the dryer. Allow all parts to dry thoroughly before storing.

♥ YOUR REDSBABY BOUNCE



'Redsbaby' is a registered Trademark of Redsbaby Pty Ltd.
ABN 31 167 364 178.