

Contents

Safety instructions	3
Description of the Appliance	4
Operation	6
Maintenance and care	8
Troubleshooting	8
General notes	8
Technical specifications	9
Customer service	9

Dear Customer,



Please read and comply with these original instructions prior to the initial operation of your appliance and store them for later use or subsequent owners.

Proper use

The appliance is intended for use as a Multi-Purpose Vac corresponding to the descriptions given in these operating instructions and the safety notes.

This appliance has been designed for use in private households and is not intended for commercial use.

- Protect the unit from rain. Do not store outside.
- **Caution:** Always use a pre-separator while vacuuming ashes and soot (order no. 2.863-139).

Use the Multi-Purpose Vac only with:

- Original filter bag.
- Original spare parts, accessories and special accessories.

The manufacturer is not responsible for any damages that may occur on account of improper use or wrong operations.

Environmental protection



The packaging material can be recycled. Please do not place the packaging into the ordinary refuse for disposal, but arrange for the proper recycling.



Old appliances contain valuable materials that can be recycled. Please arrange for the proper recycling of old appliances. Please dispose your old appliances using appropriate collection systems.

Disposing the filters and filter bags

Filters and filter bags are made from environment-friendly materials.

They can therefore be disposed off through the normal household garbage provided you have not sucked in substances that are not permitted to be thrown into household garbage.

Notes about the ingredients (REACH)

You will find current information about the ingredients at:

www.kaercher.com/REACH

Safety instructions

- *This device is not intended for use by persons (including children) with reduced physical, sensory or mental abilities or lacking experience and/or knowledge, unless they are supervised by a person responsible for their safety or are instructed by these persons on the use of the device. Children should be supervised, to ensure that they do not play with the device.*
- *Keep packaging film away from children - risk of suffocation!*
- *Switch the appliance off after every use and prior to every cleaning/maintenance procedure.*
- *Risk of fire. Do not vacuum up any burning or glowing objects.*
- *The appliance may not be used in areas where a risk of explosion is present.*

⚠ Electrical connection

The appliance may only be connected to alternating current. The voltage must correspond with the type plate on the appliance.

⚠ Risk of electric shock

Never touch the mains plug and the socket with wet hands.

Do not pull the plug from the socket by pulling on the connecting cable.

Check the power cord with mains plug for damage before every use. If the power cord is damaged, please arrange immediately for the exchange by an authorized customer service or a skilled electrician.

To avoid accidents due to electrical faults we recommend the use of sockets with a line-side current-limiting circuit breaker (max. 30 mA nominal tripping current).

⚠ Caution

Certain materials may produce explosive vapours or mixtures when agitated by the suction air!

Never vacuum up the following materials:

- *Explosive or combustible gases, liquids and dust particles (reactive dust particles)*
- *Reactive metal dust particles (such as aluminium, magnesium, zinc) in combination with highly alkaline or acidic detergents*
- *Undiluted, strong acids and alkalies*
- *Organic solvents (such as petrol, paint thinners, acetone, heating oil).*

In addition, these substances may cause the appliance materials to corrode.

Description of the Appliance

Illustrations on Page 5

When unpacking the product, make sure that no accessories are missing and that none of the package contents have been damaged. If you detect any transport damages please contact your dealer.

1 Suction hose connection

- To connect the suction hose during vacuuming.
(see description / illustration **B1**)

2 ON/OFF switch for appliance

- **Position I:** Suction or blowing
Position 0: Appliance is switched off

3 Carrying handle

- Transport the appliance using the carrying handle.

4 Cable hook

- To store the mains cable.
(see description / illustration **E2**)

5 Blowing connection

- Connect the suction hose to the blower connection, this will activate the blower function.
(see description / illustration **C1**)

6 Container closure

- Pull out to open, push in to lock.
(see description / illustration **A1**)

7 Parking position

- To rest the floor nozzle during work interruptions.
(see description / illustration **D1**)

8 Accessory mount

- The accessories compartment allows the storage of suction pipes and suction nozzles on the appliance.
(see description / illustration **E2**)

9 Steering roller

- The steering rollers are located in the compartment when the appliance is delivered. These must be attached prior to starting up the appliance.
(see description / illustration **A1**)

10 Drain screw

- Use the drain screw to empty liquids. Empty the dry dirt over the container.

11 Filter bag

Note: Do not use a filter bag for wet vacuuming!

- **Recommendation:** To vacuum fine dust, use the filter bag.
(see description / illustration **A2**)

12 Cartridge filter (already installed in the appliance)

- The cartridge filter must always be installed - with wet and dry vacuuming.
Note: Let the wet cartridge filter dry prior to using it for dry vacuuming.
(see description / illustration **E1**)

13 Suction hose with hand pipe

- Slide the suction hose into the connection, it will lock into place.
(see description / illustration **B1**)
In order to disconnect it, push down with your thumb and pull the suction hose out.

Operation

- ⚠ **Always work with an inserted cartridge filter - during wet as well as dry vacuum cleaning!**

Illustrations on Page 7

Before Startup

- Illustration **A 1**
Mount loose parts delivered with appliance prior to start-up.
- Illustration **A 2**
Recommendation: To vacuum fine dust, use the filter bag.

Start up

- Illustration **B 1**
Connect accessories.
- Illustration **B 2**
Plug in the main plug.
- Illustration **B 3**
Turn on the machine.

Dry vacuum cleaning

- ⚠ **Work only with a dry cartridge filter!**
- **Recommendation:** To vacuum fine dust, use the filter bag.
(see description / illustration **A 3**)
The filling level of the filter bag depends on the dirt that is sucked in.
The filter bag needs to be replaced more frequently while sucking in fine dust, sand, etc.
Clogged filter bags can burst - therefore make sure to replace the filter bag in a timely manner!
- **Caution:** Always use a pre-separator while vacuuming ashes and soot (order no. 2.863-139).

Wet vacuum cleaning

- Attach the accessories to vacuum moisture or wetness to the suction pipes or directly to the handle.

⚠ **Caution:**

Do not use a filter bag!

Immediately switch the appliance off if foam forms or liquids escape!

Note: *If the container is full a float closes the suction opening and the appliance works at a higher speed. Switch off the appliance immediately and empty the container.*

Blowing function

Cleaning hard to reach locations or, where vacuuming is not possible, like leaves from a gravel bed.

- Illustration **C 1**
Connect the suction hose to the blower connection, this will activate the blower function.

Interrupting operation

- Turn off the appliance.
- Illustration **D 1**
Hook the floor nozzle into the parking position.

Finish operation

- Turn off the appliance and disconnect the mains plug.

Empty the container

- Illustration **E 1**
Remove the appliance head and empty the reservoir.
Or use the drain screw to empty liquids.
Empty the dry dirt over the container.

Storing the appliance

- Illustration **E 2**
Stow away the mains cable and accessory at the machine. Store the appliance in a dry room.

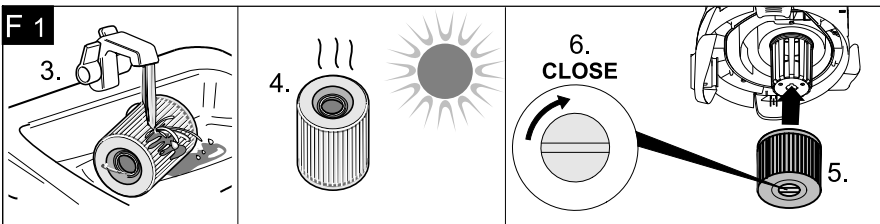
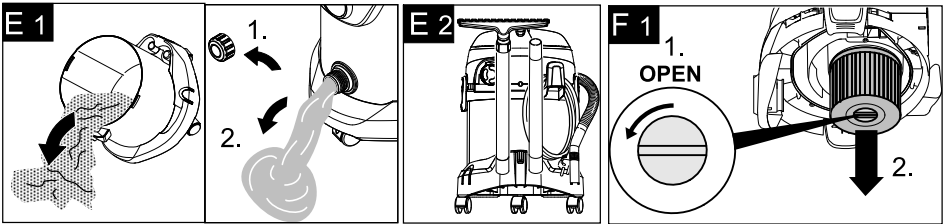
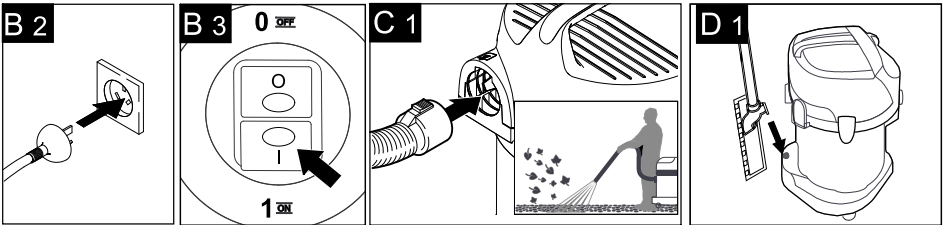
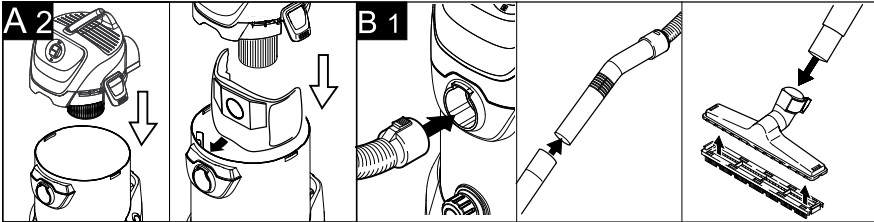
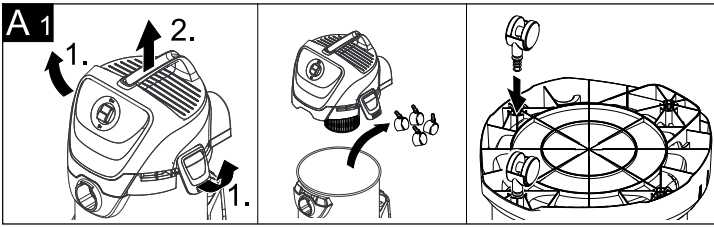

Maintenance and care

⚠ Danger

Turn off the appliance and remove the mains plug prior to any care and maintenance work.

Repair works may only be performed by the authorized customer service.

⚠ Caution

Do not use abrasives, glass or universal cleaners! Never immerse the appliance in water.

- ➔ Clean the appliance and accessory parts made of plastic with a commercial plastic cleaner.
- ➔ If required, rinse the container and accessories with water properly and dry them before reuse.
- ➔ Illustration **F.1**
Only clean the cartridge filter under running water; do not wipe or brush. Let it dry completely prior to installation.

Troubleshooting

Decreasing cleaning power

If the cleaning power of the appliance deteriorates please check the following:

- ➔ Accessories, suction hose or suction tubes are clogged, please remove the obstruction using a stick.
- ➔ Filter bag is full, install new filter bag. (see description / illustration **A.2**)
- ➔ Cartridge filter is dirty, knock off dirt from cartridge filter and clean under running water if necessary. (see description / illustration **F.1**)
- ➔ Replace damaged cartridge filter.

General notes

Warranty

The terms of the guarantee applicable in each country have been published by our respective national distributors. We will repair possible faults on your unit free of charge within the warranty period, insofar as the faults are caused by material defects or defective workmanship. Guarantee claims should be addressed to your dealer or the nearest authorized customer service centre, and supported by documentary evidence of purchase.

(See address on the reverse)

Customer Service

Our KÄRCHER branch will be pleased to help you further in the case of questions or faults.

(See address on the reverse)

Ordering spare parts and special attachments

At the end of the operating instructions you will find a selected list of spare parts that are often required.

You can procure the spare parts and the attachments from your dealer or your KÄRCHER branch office.

(See address on the reverse)

Technical specifications

Voltage 1~50/60 Hz	220 - 240	V
Output P _{nom}	1200	W
Output P _{max}	1400	W
Mains fuse (slow-blow)	10	A
Container capacity	20	l
Water intake with handle	10	l
Water intake with floor nozzle	8	l
Sound pressure level (EN 60704-2-1)	69	dB(A)
Weight (without accessories)	5,8	kg

Subject to technical modifications!

Customer service

Australia

KÄRCHER Pty. Ltd.
40 Koornang Road
Scoresby, Victoria 3179

1800 675 714 (Free Call)
www.karcher.com.au

New Zealand

Karcher Ltd.
12 Ron Driver Place
East Tamaki, Auckland

(09) 274-4603
www.karcher.co.nz

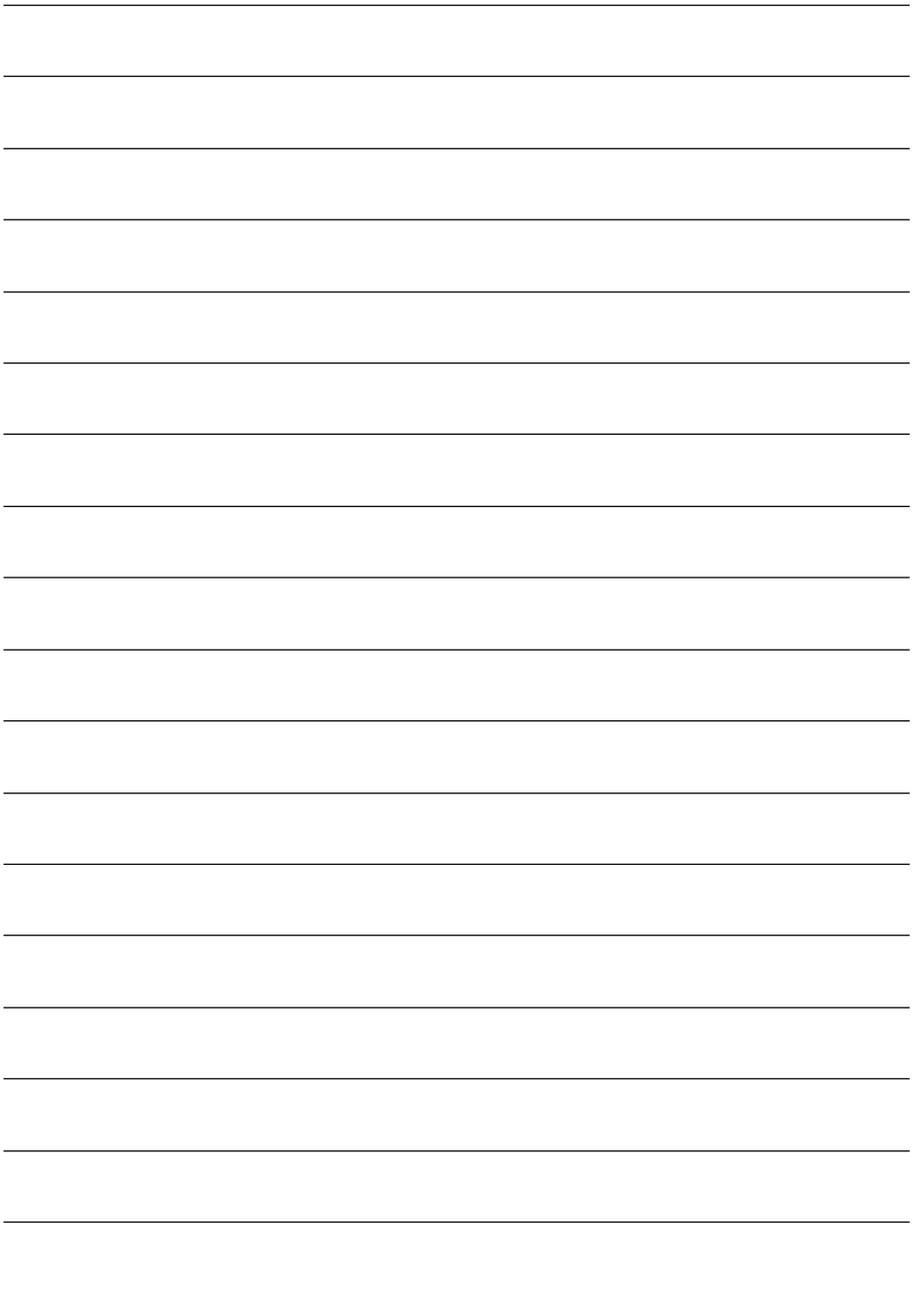

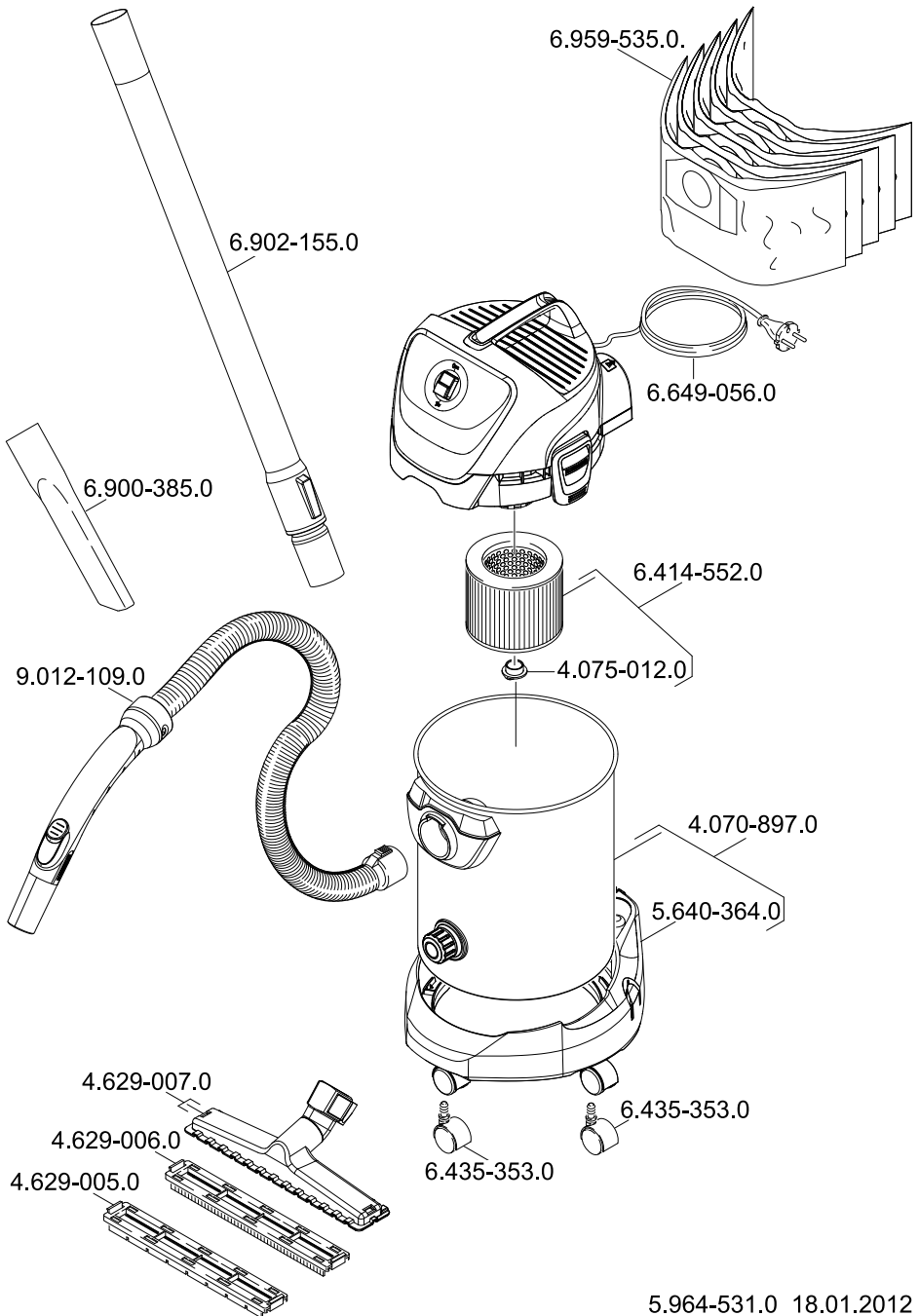



www.karcher.com.au
www.karcher.co.nz