INSTALLATION MANUAL



Ducted Inverter Reverse Cycle Air Conditioning



With the

*Classic Wall Mounted Controller
& IR Remote*

www.bonaire.com.au

INTRODUCTION 3
 General 3
 Warning 3
 Precaution 3
DIMENSIONS & CLEARANCES 5
 Indoor Unit Dimensions 5
 Indoor Unit Clearances 6
 Outdoor Unit Dimensions 7
 Outdoor Unit Clearances 8
INDOOR UNIT INSTALLATION 9
 Indoor Unit Location 10
 Notes for installation 11
 1. *Installation for the Indoor Unit* 11
 2. *Floor or Platform Mounting* 12
 3. *Levelling the unit* 12
 4. *Ducting and fittings* 12
 5. *Drainage Pipe Installation* 13
 Drainage Pipe Material & Insulation 14
 Connection Procedure 14
 Heat Insulation 14
OUTDOOR UNIT INSTALLATION 15
 Outdoor Unit Location 16
 **NOTE – The minimum pipe length must be 5m 17
 Refrigerant Pipe Installation 17
 Condenser Installation 18
 Interconnecting Pipework 18
 Suction Trapping 19
 Pipe Installation 19
 Flare Preparation 19
 Wrap the pipe 20
 Connecting the pipe work 20
 Evacuation and Charging 21
 Additional Charge 22
ELECTRICAL 23
 Warnings 23
 Other Precautions 23
 Wiring Diagram 24
 Wiring Method for the Indoor Unit 25
 Wiring Method for the Outdoor Unit 25
 Classic Wall Controller Installation 26
COMMISSIONING 28
 Commissioning of the unit 28
 Warning 28
NOTES 30

General



Bonaire Reverse Cycle Ducted Inverter air conditioners include two separate units – An Indoor and an Outdoor Unit. The two units are interconnected by two refrigerant pipes and electric cables. Unit functions are controlled by a hard wired low voltage controller and an auxiliary Infra Red Remote controller

Warning

The air conditioner must be installed by an authorised, licensed installer, according to Climate Technologies specifications and using recommended standard refrigeration grade copper, electrical cables and correct installation tools. Failure to comply with the above may void warranty!

Precaution

- Read the following “PRECAUTIONS” carefully before installing.
- The warning and caution items stated here must be followed as these important notes are related to safety. The definition of warnings and cautions used in this table below. Incorrect installation due to ignoring these instructions will cause harm and/or damage. The seriousness is classified by the following indications

 WARNING	This indication shows the possibility of causing death or serious injury
 CAUTION	This indication shows the possibility of causing injury or damage to properties only.

NOTE:

1. Injury means causing harm, burns, electrical shock, which are not serious for hospitalisation.
2. Damage of property means that property has been rendered irreparable

**WARNING**

- Only a licensed, qualified and trained specialist installer should be used to install this equipment. Installation performed by unqualified persons will potentially cause water leakage, electrical shock or fire
- Install strictly according to these installation instructions. If the installation does not comply with these installation instructions, it will potentially cause water leakage, electrical shock or fire
- Use the attached accessories and specified parts for installation. Otherwise, it will potentially cause water leakage, fire, electrical shock or the unit to fail.
- Install in the correct location which is able to withstand the unit's weight. If the strength of the structure isn't enough or the installation isn't properly executed, the unit may fall and cause injury
- For all electrical work, follow local, state & national wiring standards, regulations and these installation instructions. An independent circuit must be used. If the electrical circuit capacity is too small or a defect in the electrical work is present, it may cause an electrical shock or fire.
- When carrying out the piping connections, take care not to let air or other non condensable matter into the refrigeration circuit. Only the specified refrigerant should go into the refrigeration circuit. otherwise it may cause a lower capacity, abnormal high pressure in the refrigeration system causing component or a complete system failure, errors and/or injury.
- Grounding is necessary. It may cause electrical shock if grounding is not correct.
- Do not install the unit in a place where leakage of flammable gas may occur. If gas leaks and accumulates, it may cause a fire

Text and Illustration Copyright Climate Technologies 2010

All rights reserved. No part of this document may be reproduced or transmitted in any form or by any means, electronic or mechanical, including photocopying, recording or by any information storage and retrieval system, without prior permission in writing from Climate Technologies

In the interest of continued product improvement Climate Technologies reserves the right to alter specifications without notice. E.&O.E

Indoor Unit Dimensions

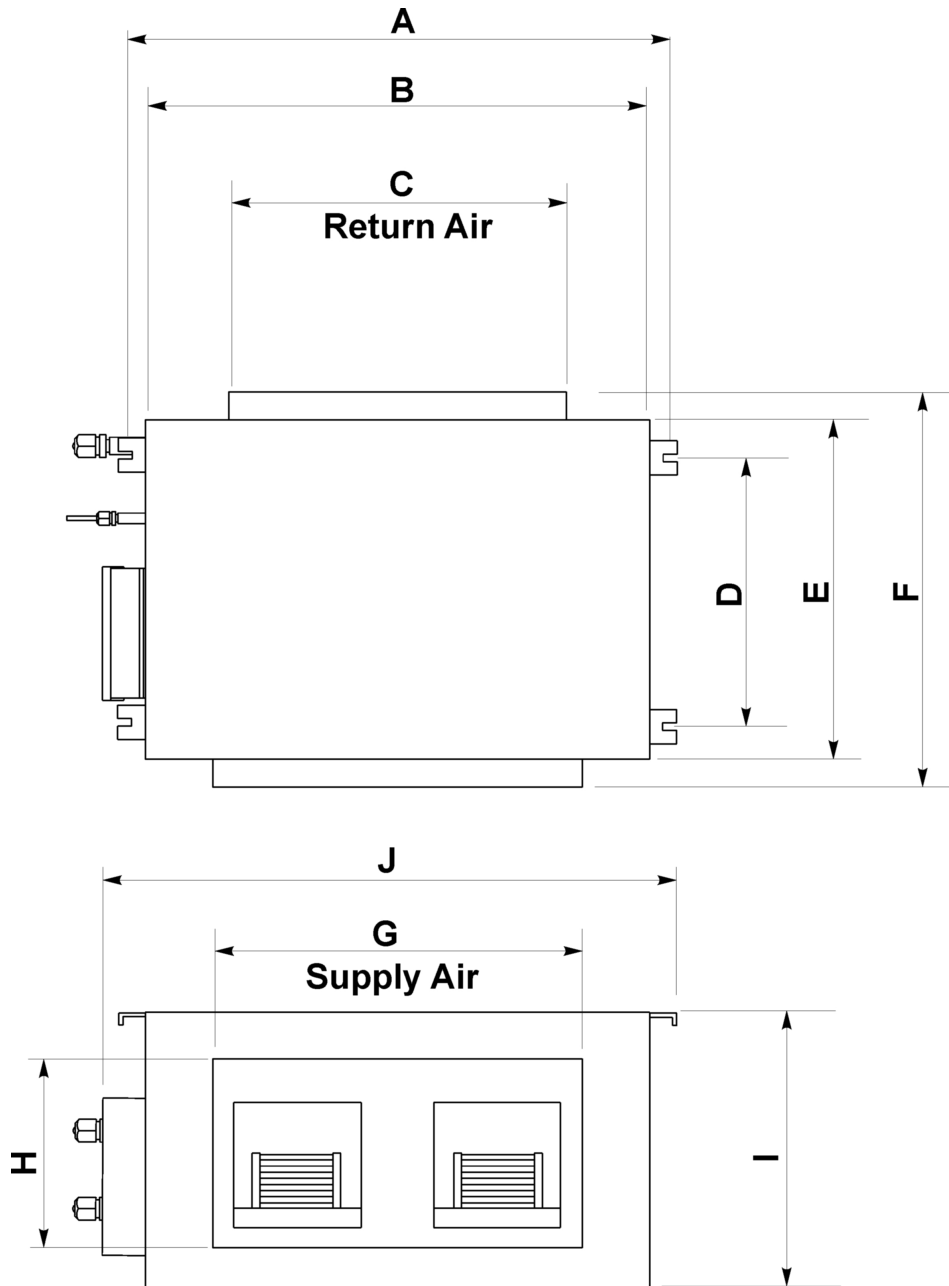

MODEL	A	B	C	D	E	F	G	H	I	J
BI12ID	1243	1200	1096 x 310	550	590	640	850	222	380	1340
BI14ID	1243	1200	1096 x 310	550	590	640	850	222	380	1340

Indoor Unit Clearances

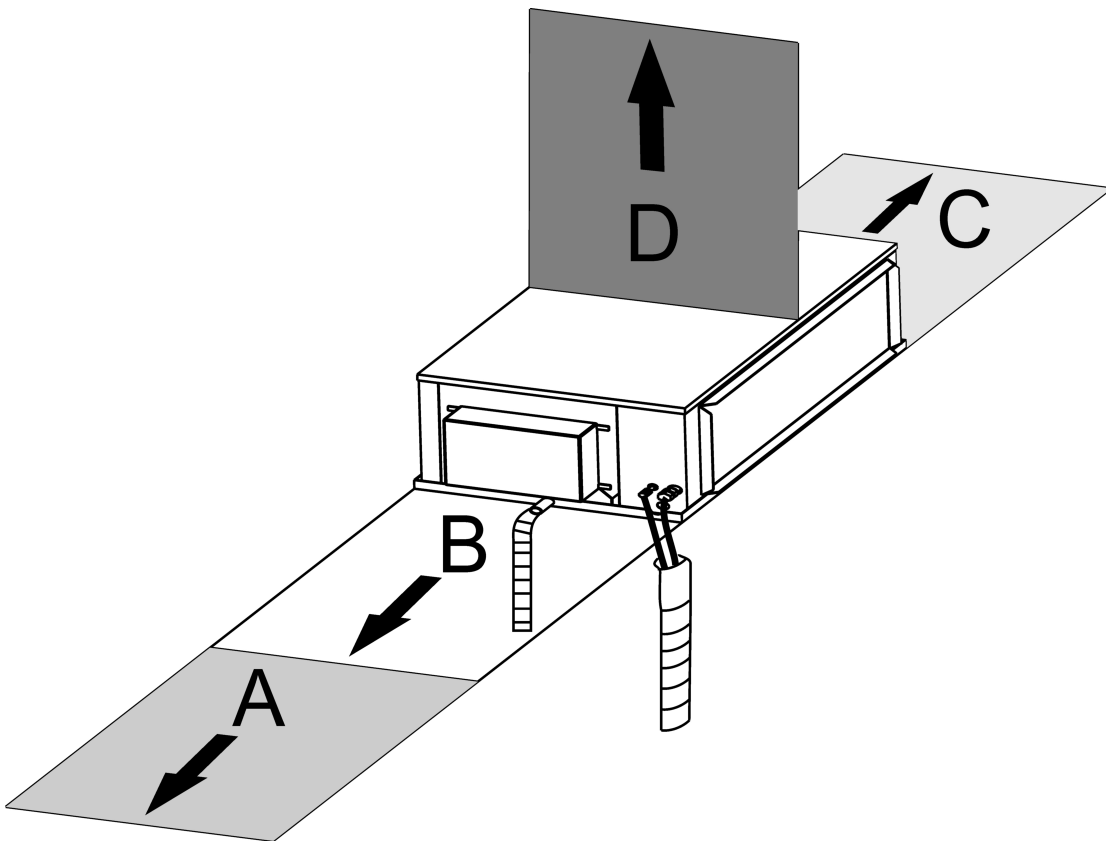

MODEL	(Mandatory)	Fan Removal Clearances Options		
	A	A + B	C	D
BI12ID	500	500	500	450
BI14ID	500	850	850	450

Outdoor Unit Dimensions

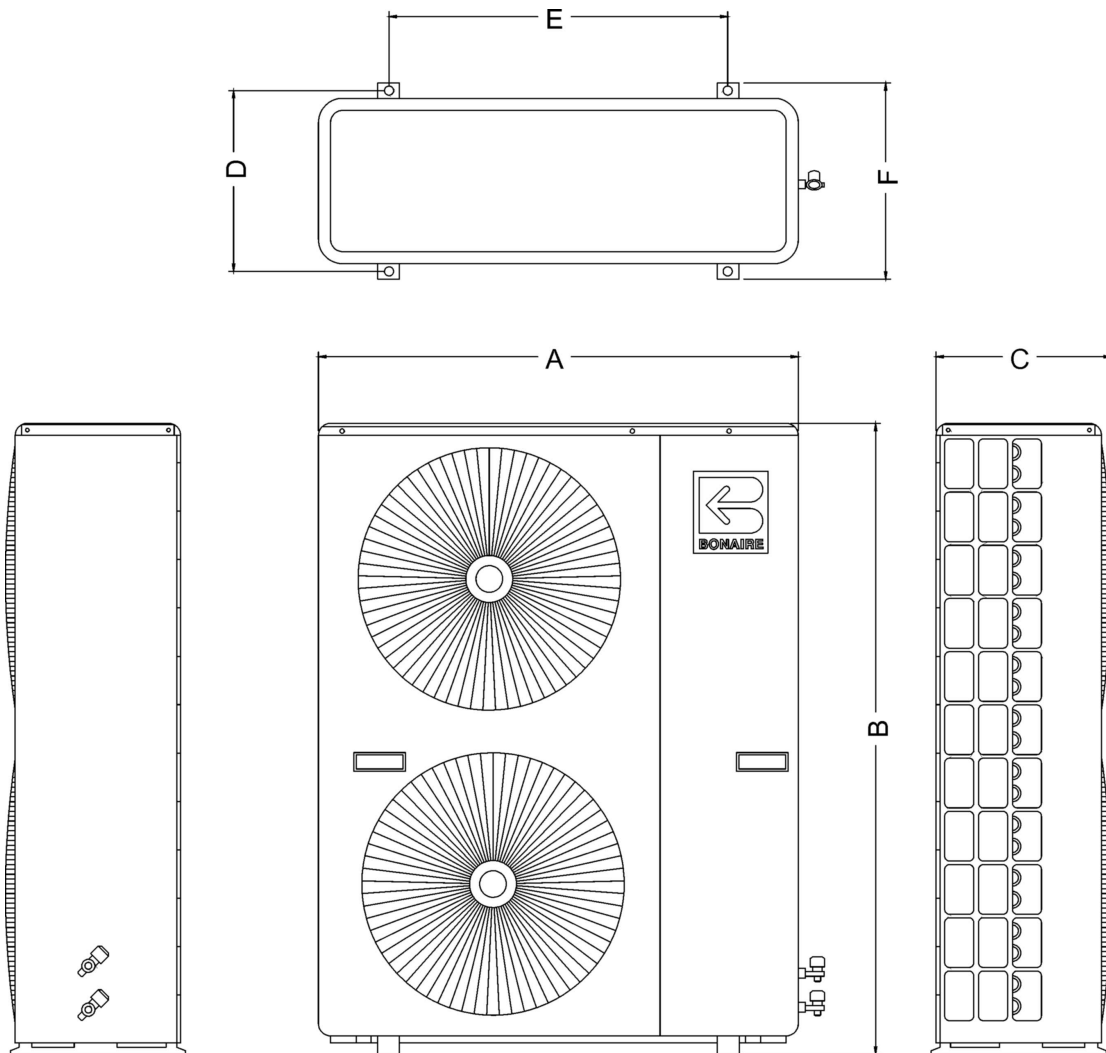

MODEL	A	B	C	D	E	F
BI12OD	940	1245	365	375	600	400
BI14OD	940	1245	365	375	600	400

Outdoor Unit Clearances

In selecting the correct location, the following criteria must be considered:

a) The outdoor unit and the indoor unit must be installed as close to each other as possible and requires a minimum pipe length of 5 meters. If longer tubing is required see the table on page 21 or consult your technical sales rep.

b) Outdoor unit installation should provide for:

1. Safe and easy service access.
2. Minimum noise and discharge air disturbance to the owner and nearby neighbours.
3. A minimum distance of 100 mm from the wall
4. If installed in a closed place (balcony, attic, etc), an outdoor air vent large enough to remove all discharge air from the condenser and must prevent hot/cold air from recirculation through the outdoor unit.
5. If several outdoor units are installed in the same area, make sure that the hot air outlet from one outdoor unit does not enter another outdoor unit.
6. Verify that any wall on which the outdoor unit is installed is capable of carrying the unit's weight and prevention measures for noise transfer into the building is undertaken. Do not install on a light unstable structure susceptible to vibration.
7. When installing on a balcony above the first floor, make sure that the outdoor unit location allows easy access for removal of the top cover and/or the entire unit, if necessary.
8. If the outdoor unit is installed in a non-accessible location, long and flexible refrigerant tubing and electrical cable must be installed to allow the unit to be moved for servicing.
9. Do not install the unit in a highly polluted area in which the air is contaminated by oil, mist, salt or sulfuric gas.
10. Do not alcove the condensing unit in a manner or the system will run at a reduced capacity or fail

Multiple Units – Lateral and Rear Spacing

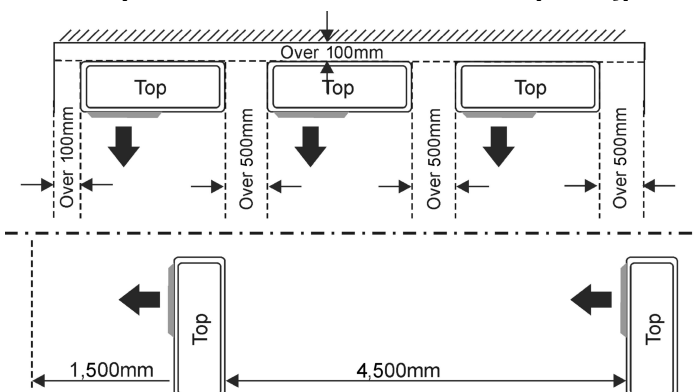

When the back is close to the wall

The top and the front need to be open. This includes protruding window sills.

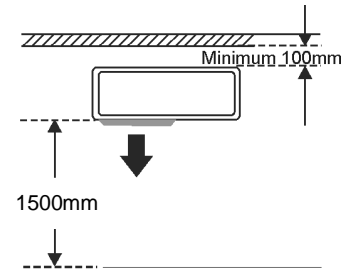

When the top is blocked

The front and the sides must be clear for these minimum clearances.

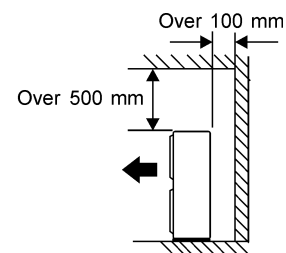

When the back & sides are blocked

The back and the side minimum clearances must be achieved

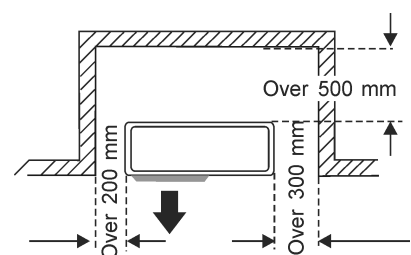

When all the sides are blocked

If all sides are blocked, this will be an unacceptable installation

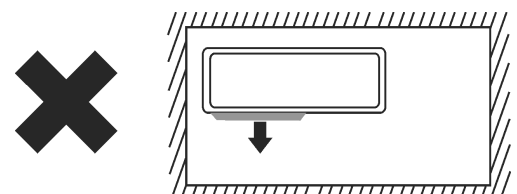

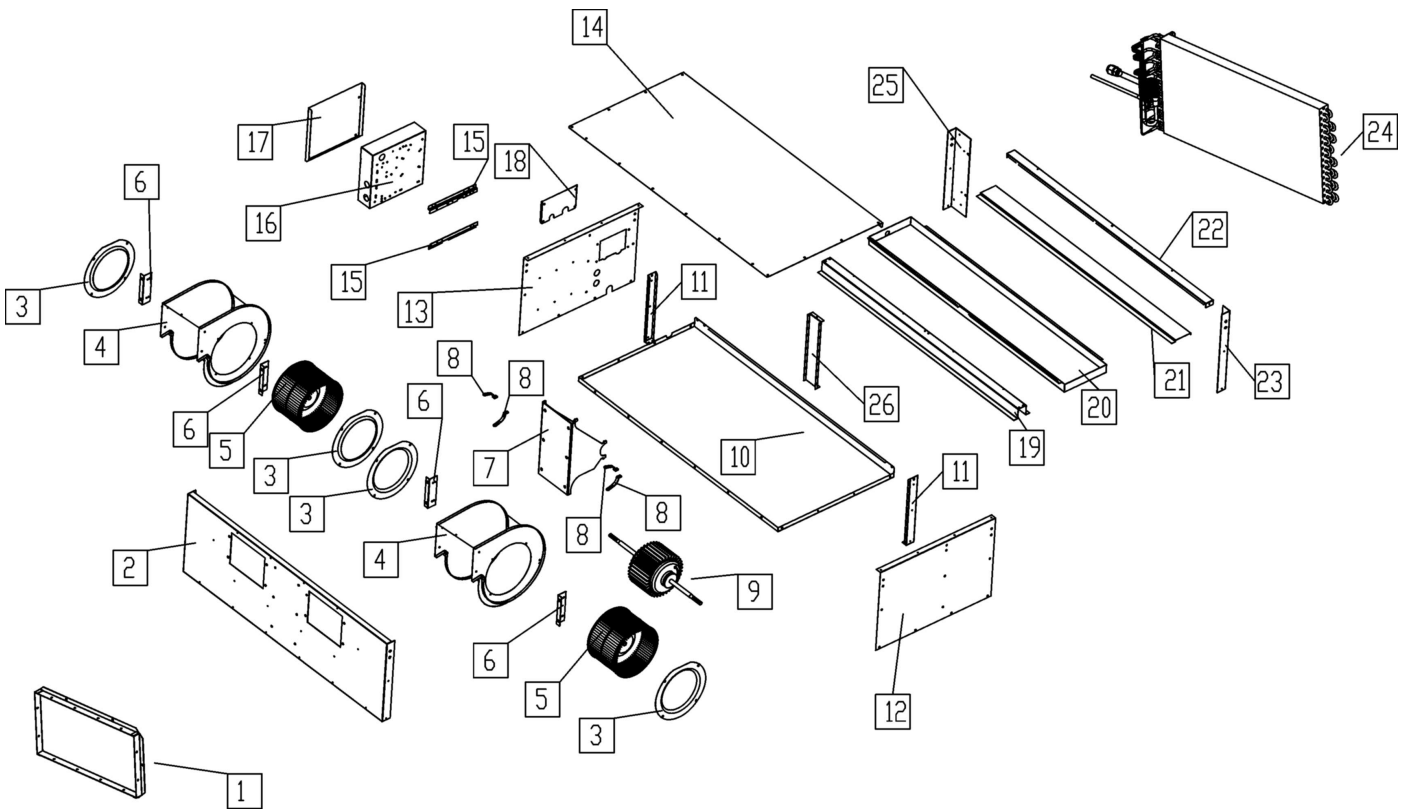

- | | |
|-----------------------------|-------------------------------------|
| 1 – Air Outlet Sub-Assembly | 13 – Left side Barrier |
| 2 – Air Outlet Assembly | 14 – Top Cover |
| 3 – Circular Air Director | 15 – Electrical Control Box Bracket |
| 4 – Scroll Assembly | 16 – Electrical Control Box |
| 5 – Fan Wheel | 17 – Electrical Control Box Cover |
| 6 – Scroll Fixing Bracket | 18 – Pipe Board Fixture |
| 7 – Fan Motor Bracket | 19 – Drip Tray Bar Fixture |
| 8 – Fan Motor Clamp | 20 – Drip Tray |
| 9 – Indoor Fan Motor | 21 – Drip Tray Air Guard |
| 10 – Base Plate | 22 – Top Crossbeam |
| 11 – Beam | 23 – Left Corner Knighthhead |
| 12 – Right Side Barrier | 24 – Evaporator Sub-Assembly |
| | 25 – Corner Bracket |
| | 26 – Centre Bracket |



CAUTION

This unit must be installed by a licensed, qualified and trained installer. Installation by unqualified persons may result in normal operations not being correctly checked, personal safety may be compromised, property damage may be sustained and the unit may be damaged. The warranty may also be void if qualified persons are not used to install the system.

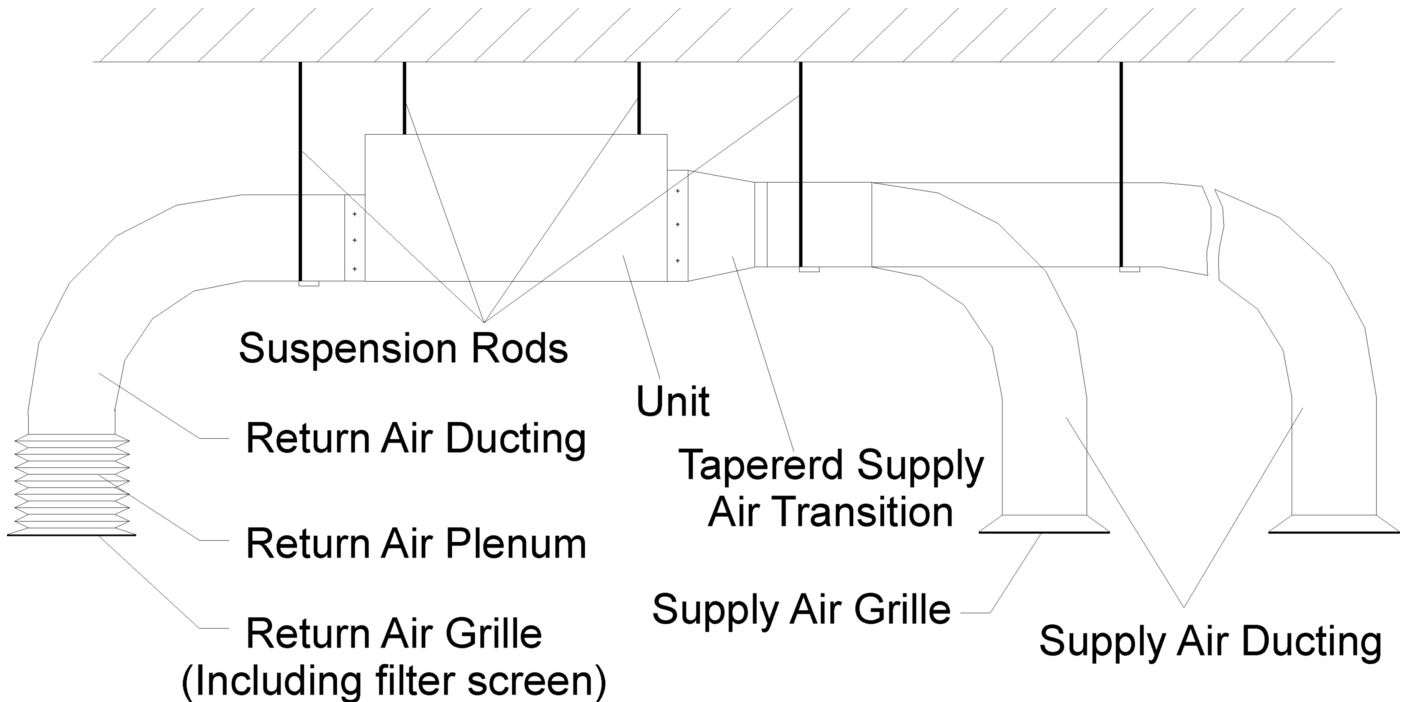

Indoor Unit Location

The indoor unit is designed for installation within a ceiling/roof space or other compartment, where there is no influence from outdoor elements.

While selecting the location, the following conditions must be assured:

- a) The location should assure free flow of the return air into the unit without interference.
- b) The unit should be located central to allow for even air flow and distribution to rooms.
- c) Avoid obstacles which may restrict the return air intake or the discharge supply air flow.
- d) The unit should not be installed close to rooms where operational noise may cause concerns (bedrooms, children rooms, etc).
- e) If installing the unit on a platform, ensure that the structure is capable of supporting the indoor unit and platform.

NOTE: *The indoor unit should not be installed outside.*

Notes for installation

- Flexible ducting used should conform to the Australian standards for insulation resistance relative to this product.
- The return-air duct should be as short as possible, with full acoustic lining. The duct diameter should be of a size correct for the installation requirements to minimise the static pressure losses.

Design and prepare in advance easy access for servicing as follows:

- The minimum height clearance for the installation is 410 mm.
- Allow for access to the electrical control box to facilitate its easy removal by opening the cover (fastened by 4 screws).
- A distance of 500mm must be kept to allow access to the electrical service panel. For the maintenance of fan wheels and motor see the indoor unit clearances. See Page 6.

1. Installation for the Indoor Unit

- Installation of the indoor unit must ensure a minimum length of refrigeration pipe work and ducting is used, therefore the Indoor unit should be installed at a reasonable distance from the Outdoor unit.
Minimum Pipe Length: 5 meters **Maximum Pipe Length: 25 meters**

Suspension Installation

- Ensure adequate strength of the building structure so as to withstand the weight of the unit.
- Determine the position of the suspension rod, align it to the suspension-mounting hole in the unit, and then tighten it (for the position of the suspension rod, see the outline dimensional drawing of the unit)

Suspension Mounting into concrete slab

- If the ceiling is old, use anchor bolts. For the newly-built ceiling, use an embedded fixed plate or embedded anchor bolts or other locally purchased parts to reinforce the ceiling, ensure that the concrete is hard enough to support the weight of the indoor unit.

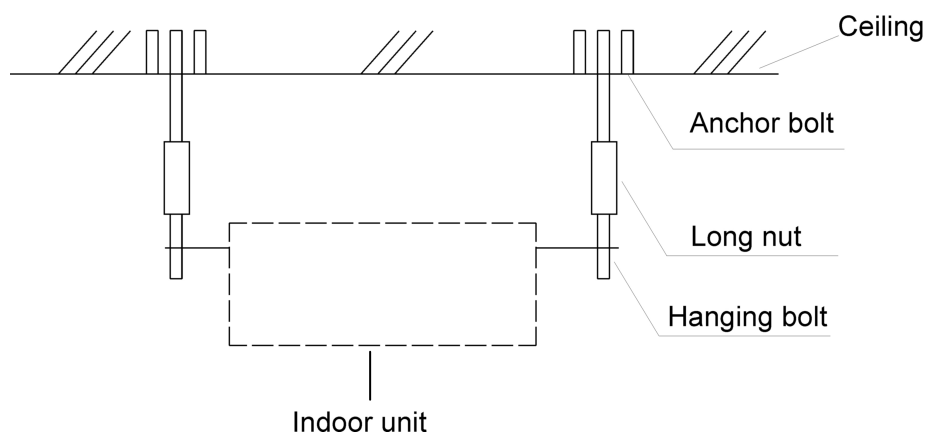

2. Floor or Platform Mounting

- Create a platform using bearers and chipboard. Place the unit platform over load bearing walls or on strategically located trusses in the roof space.
- Place serrated rubber pads or isolating springs under each corner of the unit to minimize / eliminate any noise transmission.

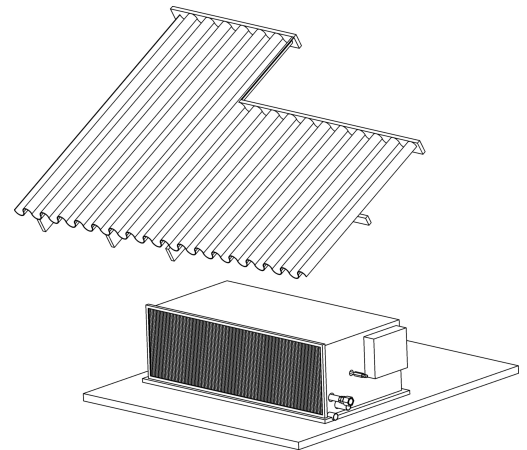

3. Levelling the unit

- Adjust the level of the unit as required. The drainpipe end of the unit must be lower by at least 5mm for good drainage.
- Take care not to damage the drain tubes or coil when lifting to adjust unit level
- For suspension mounting units, tighten the locking nuts once the revised position is determined.

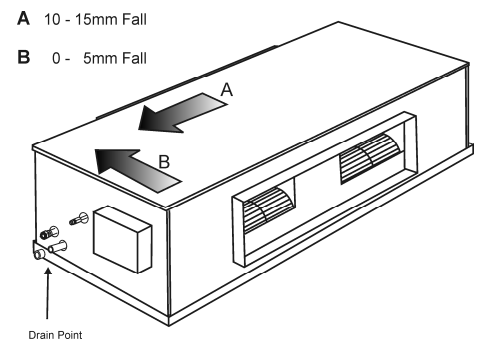

4. Ducting and fittings.

- Do not place an outlet register near the controller/thermostat as this can cause false readings
- Do not place registers so that air is blown over people e.g. above beds or couches
- To avoid exceeding maximum allowable air pressure drop in ducted system, do not use excessive lengths of duct. If a duct run exceeds 6 meters always install the next size larger ductwork.
- Flexible ductwork must be run as straight as possible between the registers.
- The airflow through each outlet must be individually set to air balance the system.
- All ductwork should be streamlined avoiding sharp angles that will reduce airflow.
- Ensure all ductwork is taped airtight so that there is no leakage.
- Balancing dampers maybe required to ensure even air distribution.
- Always install damper blades in the branch take off fittings.
- Ensure that the final ductwork bend to each ceiling register is a smooth radius so that the airflow has an even bend from the register into the room. The minimum radius bend is 1.5 times the duct diameter.
- Do not squash ductwork to fit through an opening, as airflow will be restricted. Find a better location.
- Duct work needs to be supported through its entire length to prevent air flow restrictions.
- The supply air transition is to be a tapered transition.

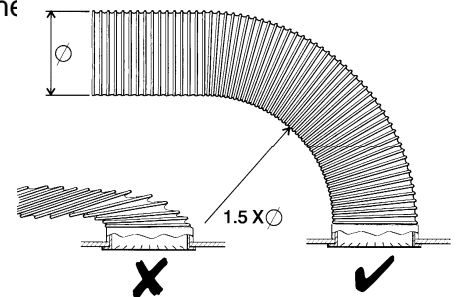

5. Drainage Pipe Installation



CAUTION

Be sure to follow this Installation Manual during the drainage installation. The drainage pipe must have the heat insulation to prevent condensing

- The drain pipe of the indoor unit must have heat insulation on it, or it will condensate, as well as the refrigeration connections of the indoor unit.
- The fall of the drain pipe should not be over 1/100, with no dipping and bending.
- The total length of the drain pipe when pulled out straight shall not exceed 20m, when the pipe is over this length, a prop stand must be installed every 1.5 to 2m to prevent dipping.
- Refer to the following pictures about the installation of the drain pipes.
- Do not impose any pressure on the connection part of the drainage pipe.

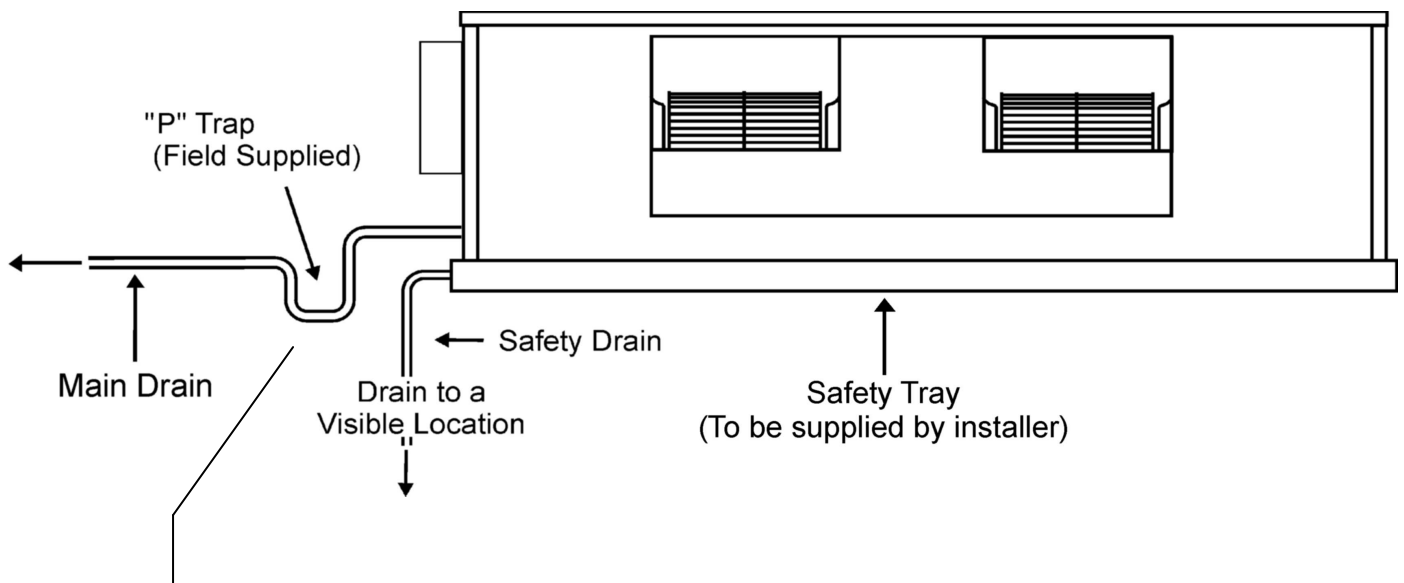

BE SURE THAT A "P" TRAP IS PRESENT IN THE MAIN DRAIN. FAILURE TO DO SO MAY RESULT IN PROPERTY AND EQUIPMENT DAMAGE.

Drainage Pipe Material & Insulation

Drainage Pipe Material	Polyvinyl Chloride Pipe (Ø32 Outer Diameter)
Heat Insulation Material	Foamed Polyethylene Insulation Plate (10mm Thickness)

Connection Procedure

Connect the transparent pipe with the PVC pipe.

- Use PVC glue on the drain connections.
- Prime both connections of the drain to be glued together
- Paste glue at the front 40mm of the PVC pipe and insert it into the transparent pipe.
- PVC Glue needs 10 minutes to dry. Do not impose pressure on the connection during the drying period.
- After the drain is completed and all glued connections are dry test the drain for leaks and flow.

Heat Insulation

Wrap the flexible hose carefully with the attached heat insulation material from the start to the end (to indoor part)

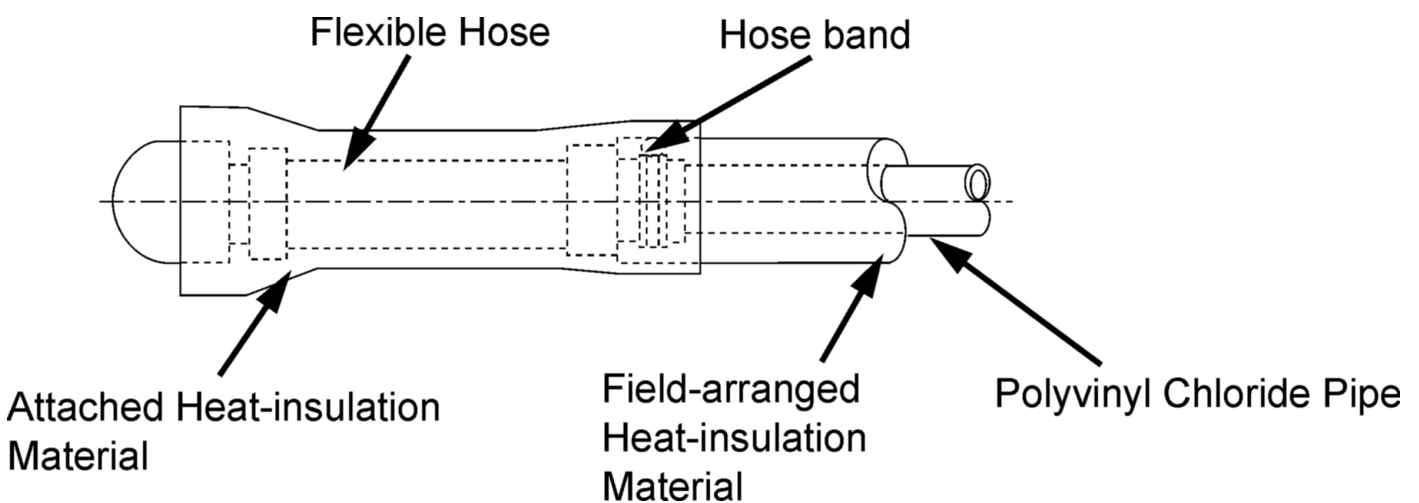

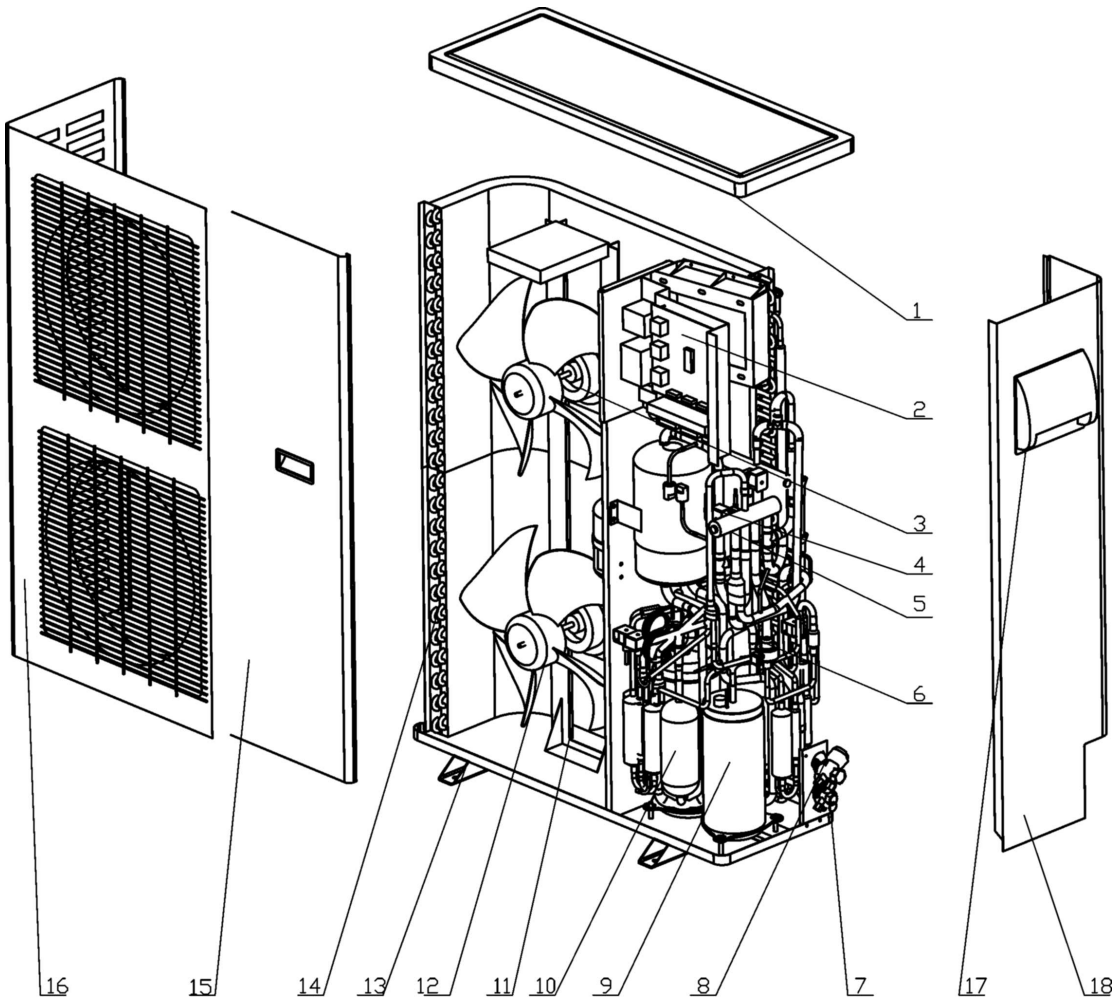

- | | |
|--------------------------------|--|
| 1- Top Cover | 14 – Condenser Sub-Assembly |
| 2 - IPM PCB | 15 – Front Right Clapboard |
| - Outdoor Main PCB | 16 – Front Left Plate |
| - Outdoor PFC PCB | 17 – Big Handle |
| 3- Outdoor Motor | 18 – Back Right Clapboard |
| 4 – Four-way valve coil | 19 – Fan Capacitor (Not Shown) |
| 5 – Four-way Valve | 20 – Compressor Capacitor (Not Shown) |
| 6 – Electrical Valve | 21 – Sensor (Not Shown) |
| 7 – High Pressure Valve | 22 – Sensor (Not Shown) |
| 8 – Low Pressure Valve | 23 – High Pressure Switch (Not Shown) |
| 9 – Compressor DA150S1C-20FZ | 24 – Reactor (Not Shown) |
| 10 – Compressor PA290X3CS-4MU1 | 25 – AC Contactor (Not Shown) |
| 11 – Outdoor Motor Support | |
| 12 – Outdoor Fan | |
| 13 – Base Sub-Assembly | |

Outdoor Unit Location

- Install it in a place where it is correct for installation, service and is well ventilated.
- Keep the required distance away and in front of the condenser as required on page 8 when carrying on installation
- Pipe length and drop height should comply with the table on the next page
- When installing the unit in a non desirable atmosphere, for example, a place of greasy dirt, salt air or other harsh environments make sure to adopt an effective protection measure.
- Avoid installing it on the roadside where there is a risk of muddy water or dust blocking the outdoor coil.
- Install it in a location where neighbours would not be annoyed by operating noise or discharged hot air
- Install it on a firm solid base that is not subject to increasing noise
- Install it in a place without restrictions to the air outlet

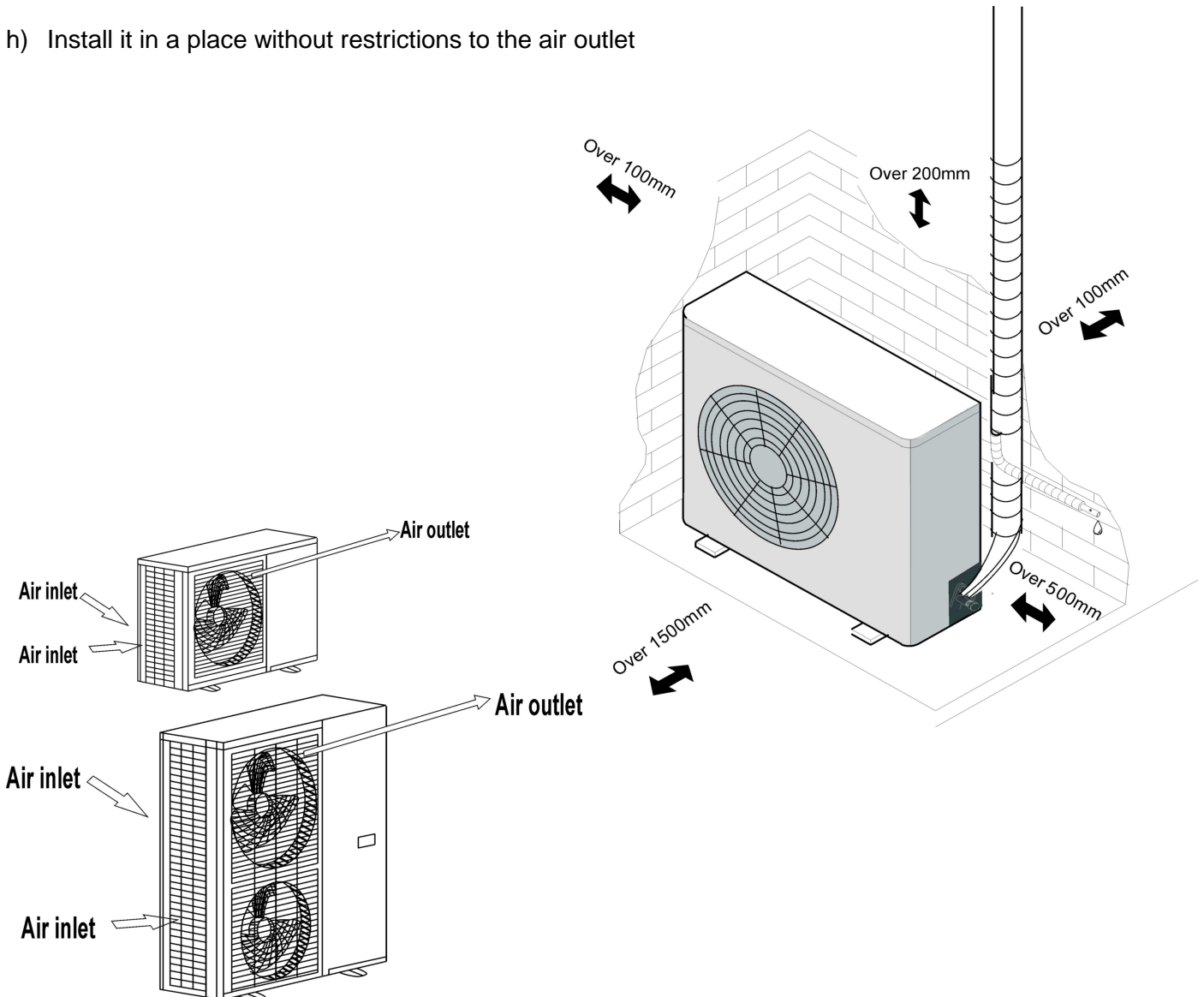

Allowed Length and Drop of Pipes

Model	Pipe Material	Liquid Side Pipe diameter (mm)	Gas Side Pipe diameter (mm)	Max Pipe Length (m)	Min Pipe Length (m)	Max Drop Height (m)	Max No. of Bends
B112ID/OD	Copper	Ø9.52	Ø19.05	25	5**	7.5	5
B114ID/OD	Copper	Ø9.52	Ø19.05	25	5**	9	5

**NOTE – The minimum pipe length must be 5m

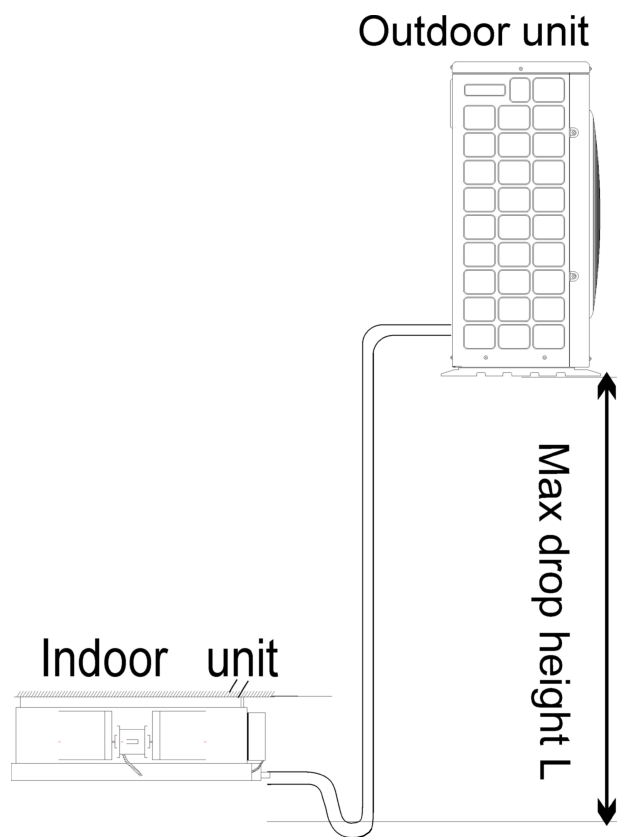

Refrigerant Pipe Installation



WARNING

Ventilate the air if there was any refrigerant leakage during the installation.
Leaked refrigerant will generate poisonous gas when in contact with fire.



WARNING

Make sure there is no refrigerant leakage after the installation.
Leaked refrigerant will generate poisonous gas when in contact with fire.

Condenser Installation

Installation on a flat surface (roof, ground, etc)

Install the outdoor unit, support it in a position elevated at least 100 mm on a concrete pad, concrete block or wooden beams, in order to allow free water flow underneath.

1. Outside the building
2. Outdoor Unit
3. Floor / ground
4. Concrete slab or equivalent
5. Wall
6. Anchor bolts
7. Serrated Rubber / Waffle Pad 40x80 mm

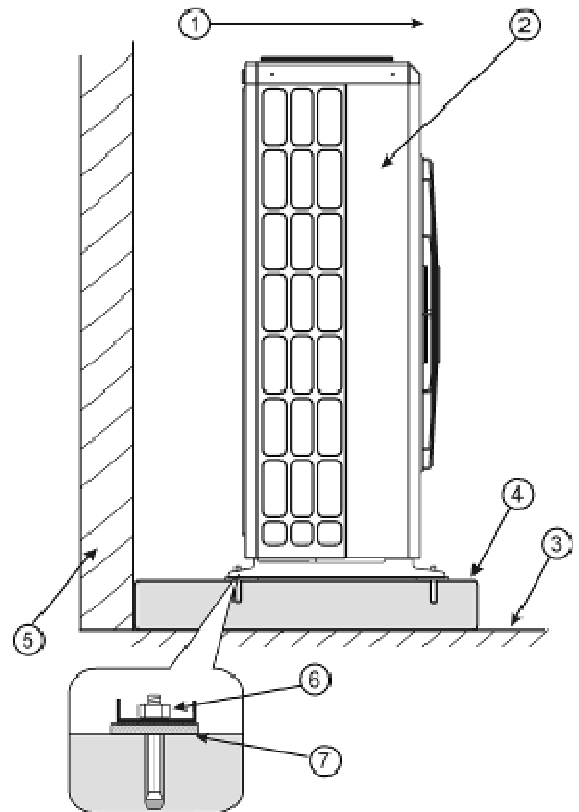

Interconnecting Pipework

The pipe work between the indoor and outdoor units consists of two copper pipes and an electrical cable routed through a 60-mm wall opening. In addition, a drainage hose is installed between the indoor unit and the closest drainage point. Connect both sections, taking the shortest, most direct route.

1. Outside wall
2. Gas (Vapor) Line
3. Liquid Line
4. Electrical Cable
5. Inside wall
6. Incline Angle

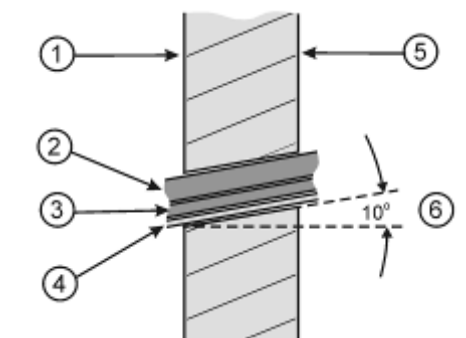

Suction Trapping

If the outdoor unit is installed above the indoor unit a suction trap (oil trap) must be fitted at the lowest point of the riser. The radius of this trap must be as short as possible. An additional trap is to be fitted every 4 meters of rise that the refrigeration pipe work travels.

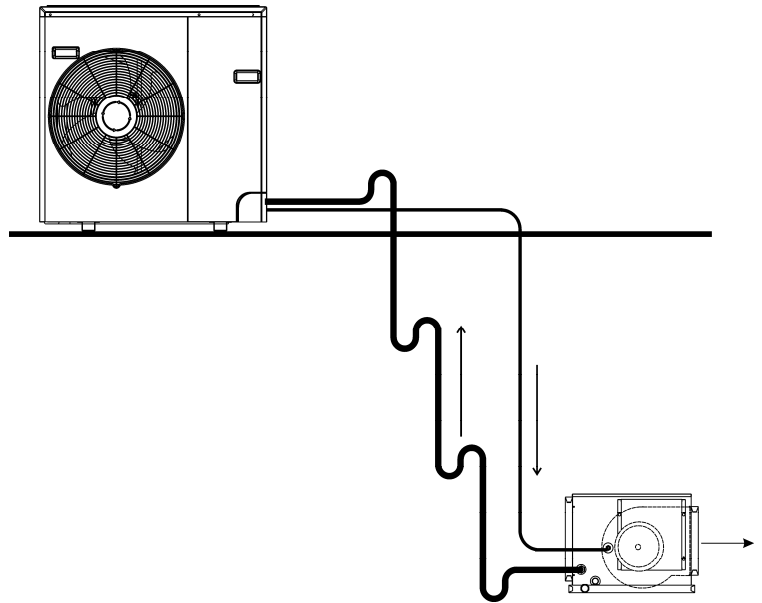

Pipe Installation

Flare Preparation

- a) Cut the pipe, using a pipe cutter. Make sure that the cut is perpendicular to the pipe axis. Ensure the pipe is de-burred and free of metal shavings

Do not use a hacksaw

- b) Slip the flare-nut over the pipe, secure the pipe in the flaring tool and perform the flare on the pipe end. The pipe projection length (A) from the flaring block varies with pipe diameter and shall be set as indicated in the table.
- c) Apply few drops of refrigeration oil to the tube before flaring.

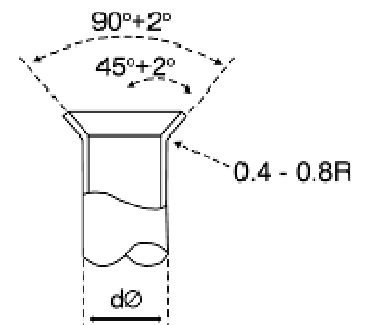
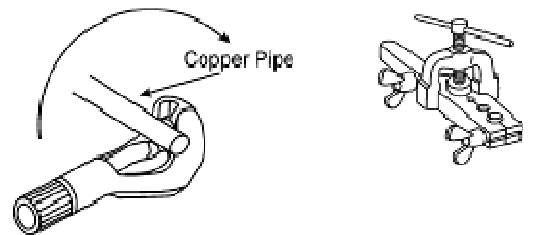

Flare Depth (A)

A (mm)	PIPE OD
1.3	9.58mm (3/8")
1.9	15.88mm (5/8")
2.1	19.05mm (3/4")

1. Copper Pipe
2. Flaring Tool

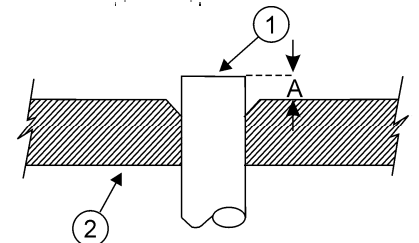

Wrap the pipe

- Wrap the connecting pipes and cables together with tape, but do not include the drainage pipe. Drainage pipe can be fixed along them separately.
- Wrap from the joint of the outdoor unit to that of the indoor unit; each round of tape should cover half of its previous one.

Connecting pipes

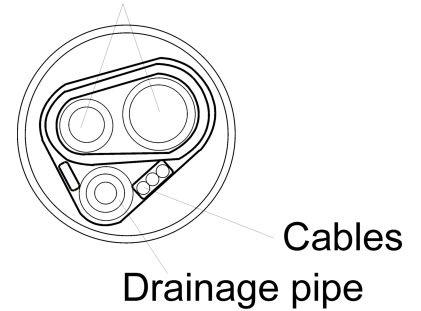

Connecting the pipe work

1. Connect and tighten the flare nuts to the refrigeration valves on the outdoor unit and to the male connectors of the indoor unit.
2. Coat the flared surfaces lightly with refrigeration oil to improve sealing.

Does not use leak sealants on the flares.

Note: First manually tighten the flare nuts, and then use two wrenches. See the table below for tightening torque values.

3. Check for leaks. Use leak detect solution or an electronic leak tester with nitrogen and a trace refrigerant. An electronic leak detector is recommended.

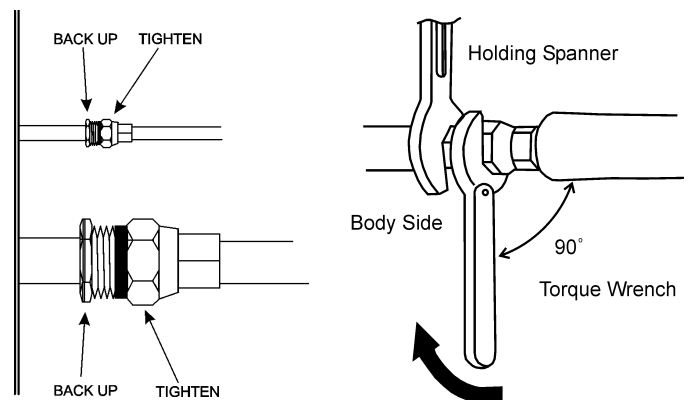

Pipe external diameter (mm)	Added wrench torque (N.m)	Pipe external diameter (mm)	Added wrench torque (N.m)
Ø6.35	13.7 ~ 16.7	Ø12.7	49.4 ~ 60.4
Ø9.52	32.7 ~ 39.9	Ø19.05	97.1 ~ 118.7
Ø15.88	61.8 ~ 75.5		

**WARNING**

This paragraph describes the necessary steps for setting up the unit for operation. Be sure to follow the instructions, to assure proper functioning of the air conditioner.

The outdoor unit is pre-charged with the correct amount of refrigerant for 5 meters. Extended refrigeration pipe runs, additional refrigerant will need to be added at 100 grams per meter above the pre-charged length, (for pipe runs in excess of 5 meters). This process must only be performed by qualified refrigeration technicians with a professional charging set and vacuum pump.

Evacuation and Charging

- a) Connect two charging hoses from the gauge set to the outdoor unit as shown in the diagram on the next page.
- b) Connect the centre hose of the gauge set to a vacuum pump and a vacc stat.
- c) Turn on the vacuum pump and make sure that the low pressure gauge reading moves from 0 KPA to a negative. Vacc the system down until the vacc stat reads 500 micron.
- d) If gauge needle does not move from 0 KPA to a negative, or the vacc stat wont pull down to 500 micron this indicates a leak. Take the following measures: tighten all connections; if leaking stops when the pipe work connections are tightened, proceed from step c. If leaking persists even after connections are tightened, nitrogen charge the refrigeration lines and detect the leak, repair it then proceed from step c; be sure to proceed only after all leaks have been eliminated.
- e) Close the valves of both the gas and liquid sides of the charging set and turn off the vacuum pump. Make sure that the gauge needle does not move or the vacc stat start to rise for 5 minutes. If either starts to rise this could indicate a leak or moisture in the refrigeration pipe work.

**Cautions**

- f) When performing the following steps, avoid any exposure to the service valve ports; remember that the system is under pressure.
- g) Remove the valve caps from the service valves. Starting with the liquid line position both valves to "open" using a 5mm Hex/Allen key wrench. Open each valve by rotating the centre spindle in an anti-clockwise direction until fully back seated.
- h) Disconnect the charging hoses from the vacuum pump and from the service ports of both the three-way valves.
- i) Replace the service port and valve caps of both tree-way valves and tighten them with a torque wrench; see table of torque values listed on the previous page.
- j) Replace valve caps of both service valves. Check for gas leakage with a leak detector or bubble up.

1. Charging Set
2. Vacuum Pump
3. Outdoor Unit
4. Service Port
5. Valve Cap
6. 3-Way Gas Valve
7. 3-Way Liquid Valve
8. Valve Cap
9. Liquid Flare Connection
10. Gas Flare Connection
11. Indoor Unit

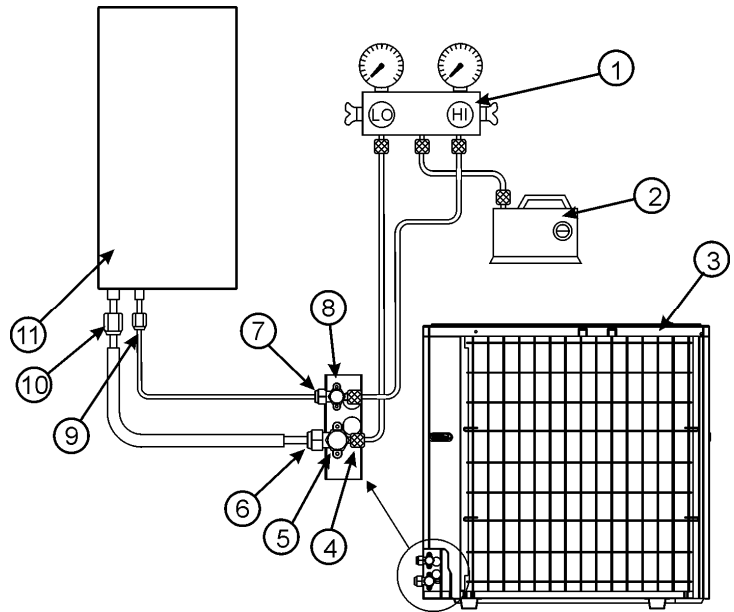

Additional Charge

- 1) Add 100 grams per meter of 9.53 (3/8") liquid line over and above the specified system pre-charged length. See the unit name plate for this information. DO NOT exceed the maximum equivalent pipe length on each unit.
- 2) Service port on the liquid service valve is not supplied on all units.

1. Valve Protection Plug
2. Insert 5mm Hex / Allen key to open/close the Refrigerant Valve
3. Valve Protection Cap
4. Refrigerant Valve
5. Service Port cap
6. Flare Nut
7. Valve Mounting Bracket
8. Copper Tube

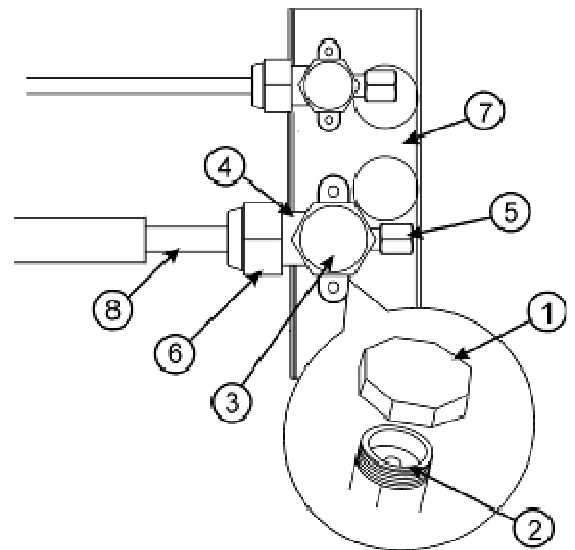



Warnings

- Supply cables and interconnecting cables should be sized according to AS3008.1 and maximum current of the unit.
- Do not apply any pressure on the terminals used for connection. Improper connection may cause fire.
- Grounding must be properly done. The grounding wire should be away from gas pipes, water pipes, telephone, lightning rods or other grounding wires. Improper grounding may cause electric shock.
- Electric Wiring must be done by a qualified electrician.
- Use a separate circuit according to national regulations.
- The temperature of the refrigerant circuit will be high, please keep the interconnecting cables away from the refrigeration pipes.
- If the wiring capacity is not enough, electric shock or fire may occur. An all-pole disconnection switch having a contact separation of at least 3mm in all poles should be used.

Other Precautions

Be sure to install the correct sized circuit breaker or nuisance tripping or a fire may occur.

- The supply cable is to be selected according to national and local regulations.
- The outdoor unit power cable should be selected and connected according to the outdoor unit installation manual, local and national regulations.
- Wiring should be away from high temperature components, or the insulation layer of the cables may be damaged.
- Use cable clamps provided in the units to fix the cables in position after connection.
- The control cable should be wrapped together with the heat insulated refrigerant pipes.
- Connect the indoor unit to the power only after the refrigeration pipe work has been vacuumed and charged.
- Do not connect the power wire to the signal wire connection terminals or damage may occur.

Important Notes

1. Refer to AS3008.1 for the sizing of the supply cable for the unit.
2. Refer to AS 3008.1 for voltage drop calculations and values to avoid voltage drop.
3. The cross section of ground wire for the entire set of air conditioners should be 2.5mm² at least.
4. Multi stranded cables with an insulation rating of at least V90 250V should be used.

Wiring Diagram

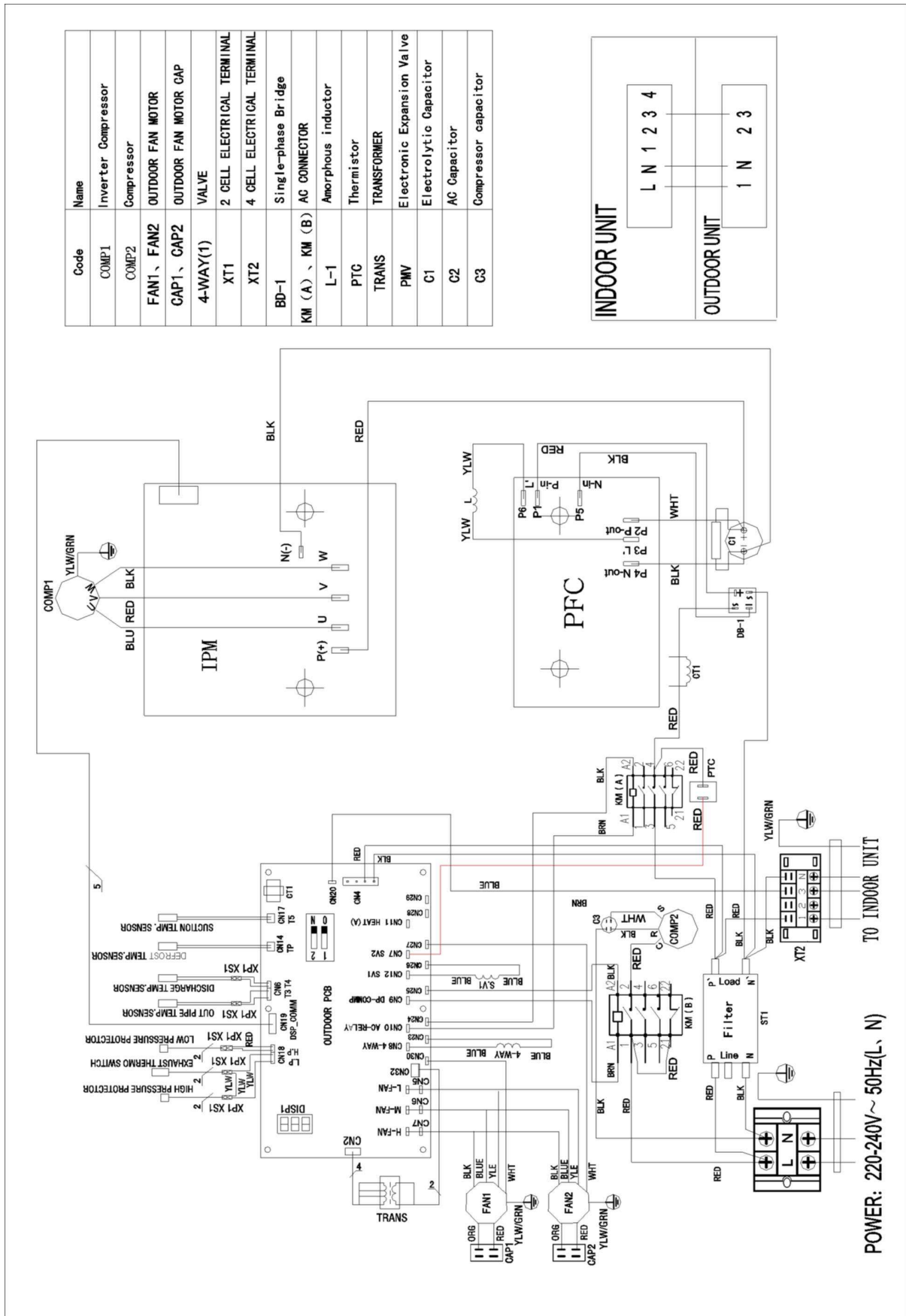

Code	Name
COMP1	Inverter Compressor
COMP2	Compressor
FAN1, FAN2	OUTDOOR FAN MOTOR
CAP1, CAP2	OUTDOOR FAN MOTOR CAP
4-WAY(1)	VALVE
XT1	2 CELL ELECTRICAL TERMINAL
XT2	4 CELL ELECTRICAL TERMINAL
BD-1	Single-phase Bridge
KM (A), KM (B)	AC CONNECTOR
L-1	Amorphous inductor
PTC	Thermistor
TRANS	TRANSFORMER
PMV	Electronic Expansion Valve
C1	Electrolytic Capacitor
C2	AC Capacitor
C3	Compressor capacitor

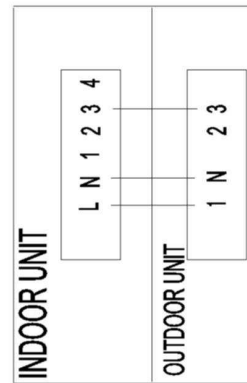

POWER: 220-240V ~ 50Hz(L, N)

Wiring Method for the Indoor Unit

Wiring method for indoor unit: Open the electrical control box to carry out the wire connections. Notice that the connecting wire should be passed through the wire inlet rubber grommet on the box. Connect the wires according to the stipulations on the wiring diagrams. The wire splices at the end of the terminals should be tightly compacted. Wiring should not be loosely connected.

Wiring Method for the Outdoor Unit

1. Install a dedicated circuit from the mains switch board.
Circuit breaker requirements as per table below.
2. Connect the mains cables to the incoming connection block on the outdoor unit
3. Connect the low voltage control cable from the indoor unit to the comms port available on the outdoor PCB.

Use supply wire sizes as per local electrical codes and regulations.

Model	Required Circuit Breaker Size	Full Load Amps
BI12ID/OD	32A	26.6A
BI14ID/OD	40A	30A

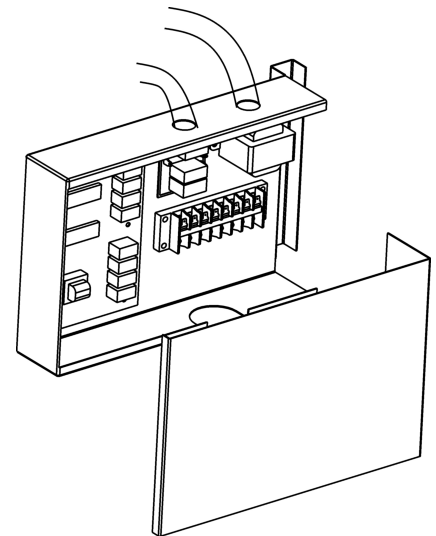

Electrical Control Box

Please Note: Cable sizes are subject to length of cable run and full load amps calculated via AS 3008.1

Classic Wall Controller Installation



1) Detach the rear cover of wall controller.

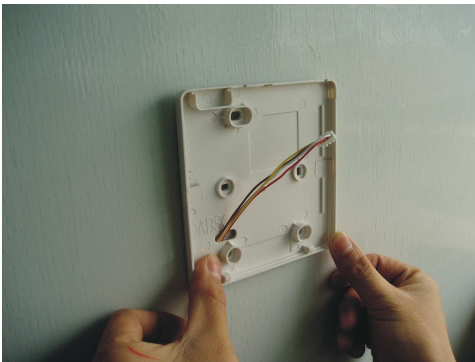

2) Before fixing the back cover on the wall, ensure that the length of the LCD display wiring which will go through the back cover will be at least 100mm.



3) Install four wires according to the directions on the back cover then screw down the fixing screws;

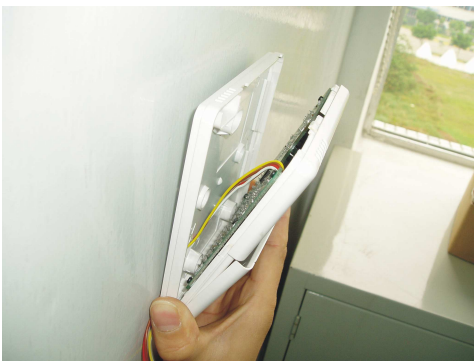

4) Test communications and then fix the wall controller to the backing plate



- 5) Ensure the wall controller can be used properly after installation.

Note:

Before installing the wall controller for the indoor unit, the user must shut down the power supply of the indoor and outdoor unit first, and then pull out the display PCB from the main PCB, and then connect the wall controller to the main PCB.

Commissioning of the unit

Warning

The unit's sump heater must be energised for at least 12 hours prior to start up of the compressor or failure may occur.

- Ensure all electrical terminals and connections are tight.
- Ensure fan blades and wheels are tight and spin freely.
- Ensure service valves are open.
- Leak test refrigeration pipe work connections.
- Drain and safety tray drain are connected and tested.
- Check all ducting is connected and air tight
- Ensure return air filter is fitted.
- Power up the unit.
- Test supply voltage is correct at the main terminal strip.
- Test run the system in all modes (Heating, Cooling and Ventilation)
- Check air flow to all outlets are balanced as required.
- Test all sundry items (such as damper motors).
- Fill in the commissioning report.
- Refit all covers to the units
- Demonstrate the operation of the system to the customer.
- Explain to the customer the cleaning of the filters.
- Explain that the air conditioning system requires preventative maintenance and how often it should be done.
- Give the commissioning report, owner's manual and certificates of compliance to the customer.
- Ensure the site is cleaned of all rubbish.

Commissioning Report

Date of commission _____

License number _____

Company name _____

Invoice number _____

Company contact details _____

Technician's signature _____

Customer's signature _____

Technician _____

- Filter installed.
- Check and test condensate drain.
- Check electrical connections for tight connections.
- Check refrigeration flares for leaks.
- Check for fan blade damage and security on the motor shaft.
- Test run system.
- Ambient temperature _____
- Voltage. No load _____ VAC. Loaded _____ VAC.
- Check pressures after 15 minutes running time. HP _____ psi, LP _____ psi.
- Check current draws after 15 minutes running time. Supply _____ Amps.
Compressor _____ Amps.
- T/D over the indoor coil. _____ R/A temp _____ S/A temp _____ T/D.
- T/D over the outdoor coil. _____ Air on. _____ Air off. _____ T/D.
- Check for air flow to all registers.
- Ensure condenser is level and secure.
- Record condenser clearances

- Clearance F _____
- Clearance G _____
- Clearance H _____
- Clearance I _____

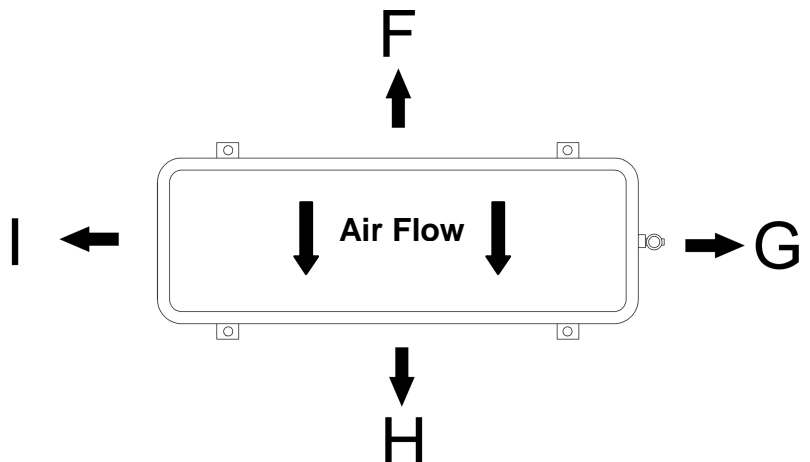



“Excelling today for a better tomorrow”

Manufactured by
Climate Technologies
ABN 13 001 418 042

26 Nylex Avenue
Salisbury, SA 5108
Australia

www.bonaire.com.au
